



Florida Municipal Power Agency

REQUEST FOR PROPOSALS

FOR

FURNISH & DELIVERY

OF

CUSTOM ALUMINUM

WORK BOAT AND TRAILER

Florida Municipal Power Agency
8553 Commodity Circle
Orlando, Florida 32819-9002
(407) 355-7767 Fax (407) 355-5796

REQUEST FOR PROPOSALS

(This is not an order)

R
E Florida Municipal Power Agency
T TO: 8553 Commodity Circle
U Orlando, Florida 32819
R Attn: Sharon Samuels
N

RFP FMPA 2021-250

Date Issued: July 13, 2021

Telephone: (407) 355-7767

SEALED PROPOSALS MUST PHYSICALLY BE IN THE FLORIDA MUNICIPAL POWER AGENCY OFFICE PRIOR TO PROPOSAL OPENING AT **10:00 A.M. ON AUGUST 25, 2021**, WHICH WILL BE IN THE FMPA FIRST FLOOR CONFERENCE ROOM LOCATED IN THE FMPA BUILDING AT 8553 COMMODITY CIRCLE, ORLANDO, FLORIDA 32819.

- Proposals shall be submitted on the forms provided and must be manually signed.
- Proposals shall be sealed in an envelope with the proposal number, opening date, and time clearly indicated.
- Proposals received after the opening date and time may be rejected and returned unopened.
- The attached Request for Proposals shall become part of any purchase order resulting from this Request for Proposal.

DESCRIPTION

JULY 2021

**Florida Municipal Power Agency
Request for Proposals for
Furnish & Delivery of Custom Aluminum Work Boat and Trailer**

See attached Request for Proposals, General Conditions, Specifications, and Proposal Forms for detailed description.

It is the intent and purpose of the Florida Municipal Power Agency that this Request for Proposal promotes competitive bidding. It shall be the proposer's responsibility to advise if any language, requirements, etc. or any combination thereof, inadvertently restricts or limits the requirements stated in this Request for Proposal to a single source. Such notification must be submitted in writing and must be received by not later than ten (10) days prior to the proposal opening date.

ADVERTISEMENT

Proposal For

July 2021

**FLORIDA MUNICIPAL POWER AGENCY
REQUEST FOR PROPOSALS FOR
FURNISH & DELIVERY OF CUSTOM ALUMINUM WORK BOAT AND TRAILER**

**REQUEST FOR PROPOSALS
FMPA 2021-250**

Sealed proposals will be received by the Florida Municipal Power Agency (FMPA), 8553 Commodity Circle, Orlando, Florida 32819 until 10:00 A.M. ON **AUGUST 25, 2021**, when at that time Proposals will be opened publicly by a FMPA representative.

The proposal is for the Furnish & Delivery of Custom Aluminum Work Boat and Trailer as more fully described in the Request for Proposals package.

RFP packages for this project may be obtained from FMPA at the above address, by telephone (407) 355-7767, via e-mail request to bidinfo@fmpa.com, or via Internet download at www.fmpa.com.

No proposal may be altered, withdrawn, or resubmitted after the scheduled closing time for receipt of proposals. Proposals received after the day and time stated above will not be considered.

Proposals will be accepted for Furnish & Delivery of Custom Aluminum Work Boat and Trailer from companies who have established, through demonstrated expertise and experience, that they are qualified to provide the services as specified.

The Florida Municipal Power Agency reserves the right to reject any and all proposals in total or in part and to waive defects in proposals.

Jacob Williams
General Manager and CEO
Florida Municipal Power Agency

FLORIDA MUNICIPAL POWER AGENCY Request for Proposals for

Furnish & Delivery of Custom Aluminum Work Boat and Trailer

1. **FMPA Description**

Formed by Florida's municipal electric utilities in February 1978, the Florida Municipal Power Agency (FMPA or the Agency) is a non-profit, governmental, wholesale electric utilities company created to serve the needs of municipal electric utilities in Florida. Of the 34 municipal systems in the State, 31 are FMPA members who participate at varying levels in Agency activities.

2. **Introduction - General Description of Services Sought**

Florida Municipal Power Agency, (FMPA/Owner) invites proposals for furnish and delivery of a Custom Aluminum Work Boat & Trailer. Based on the relevant previous experience, your firm has been selected to receive this RFP and is invited to submit a proposal to supply the equipment described herein.

The scope of work includes, furnishing the equipment and delivery to Stock Island generating facility, Key West, Florida. The delivery shall be made at 6900 Front Street Extended, Stock Island, FL 33040.

MATERIALS

All materials shall comply with engineering plans provided herein.

3. **Overview**

Upon selection of the awarded Contractor(s), FMPA will enter into a Master Agreement specifying terms and conditions. FMPA will issue a Purchase Order with project-specific technical specifications.

The submission of a proposal implies a general acceptance on the part of the bidder of the terms of this RFP, form of contract, and especially of those parts establishing warranties and guarantees.

4. **Purchasing Services**

Subsequent to the award, FMPA shall issue Purchase Orders to the Contractor(s) awarded the agreement pursuant to this Request for Proposal.

5. **Indemnity**

After notification of award, the successful bidder shall indemnify and save harmless FMPA from and against all claims, suits, actions, damages, or causes or action arising during the terms of the resulting agreement for any personal injury, loss of life, or damage to property sustained by reason of a result of the performance of the services or delivery of goods for which the resulting agreement was entered into, or its agents, employees, invitees, and all other persons, and for and against any orders, judgements, or decrees, which may be entered thereto, and from and against all costs, attorney's fees, expenses and liabilities incurred in or by reason the defense of any such claim, suit or action, and the investigation therefore.

Nothing in the award, resulting agreement, contract or Purchase Order shall be deemed to affect the rights, privileges and immunities of FMPA as set forth in Florida Statute 768.28.

The successful bidder(s) covenants and agrees to indemnify and save harmless FMPA and to defend from all cost, expenses, damages, attorney's fees, injury or loss to which FMPA may be subjected by any person, firm, corporation, or organization by reason of any wrongdoing, misconduct, want, or need of care or skill, negligence or default or breach of contract, guaranty, or warranty, by the successful bidder(s), his employees, his agents or assigns.

6. Notice to Proposers

Sealed proposal packages will be received until **10:00 A.M. on August 25, 2021** ("Proposal Due Date") at the offices of Florida Municipal Power Agency. Each proposer is required to submit a Proposer Information Form (included in this RFP package), other forms included in this package as appropriate, and all other information necessary to allow a complete evaluation of the proposal. Registered proposers will be notified through the issue of RFP addenda of any change in the Proposal Due Date or other necessary revision to information contained in this RFP. FMPA reserves the right to reject all proposals received after the Proposal Due Date.

One (1) original hard copy (including original signatures) and one electronic version of the proposal response package should be sealed and delivered to the following address:

Ms. Sharon Samuels
Florida Municipal Power Agency
8553 Commodity Circle
Orlando, Florida 32819

Clearly legible on the outside of the sealed envelope shall be "**Custom Aluminum Work Boat and Trailer, FMPA RFP 2021-250**".

7. Duration of Offer

Proposals submitted in response to this RFP are irrevocable 120 days. This period may be extended at FMPA's request only by written agreement of the proposer. The content of this RFP and the proposal of the successful proposer will be included by reference in any resulting contract.

8. Right of Rejection

This RFP is not an offer establishing any contractual rights. This solicitation is solely an invitation to submit proposals.

FMPA reserves the right to:

- Reject any and all proposals received in response to this RFP;
- Waive any requirement in this RFP;
- Waive any irregularities, regardless of the severity

- Not disclose the reason for rejecting a proposal;
- Not select the proposal with the lowest price; and
- Seek and reflect clarifications to proposals.
- Negotiate with the selected bidder in the event that the price exceeds available funds.
- Select the proposal that is in the best interest of FMPA

9. Proposal Contents

The submission of a proposal implies a general acceptance on the part of the bidder of the terms of this form of contract, and especially of those parts establishing warranties and guarantees

The proposal should include a description of the firm's capabilities and experience with providing the requested product/services, including a description of any special qualifications which are indicative of working familiarity with similar projects.

The following information must be included:

1. Demonstration of first-hand experience in providing similar services to those requested in this RFP;
2. Description of the resources available, including staffing levels, qualifications of key personnel who will be performing the work, equipment and capabilities; and locations of offices;
3. Proof of Insurance coverage;
4. Proof of licenses and certifications as applicable;
5. Cutsheets, shop drawings, and/or product data, as applicable.
6. A schedule for the work, including the range of anticipated completion/delivery dates.
7. General description of how projects will be managed, including project management and invoicing;
8. Identification of any work or services that may be provided by a subcontractor. Bidder shall provide information similar to that above concerning subcontractor's equipment, personnel, and qualifications; including a minimum of three (3) reference projects with similar scope of work. If after award of the RFP, the successful bidder(s) desire to utilize a subcontractor other than listed in the bid, the bidder must obtain approval of the subcontractor from FMPA. Denial of a subcontractor by FMPA will NOT absolve the bidder from getting the work done for the contracted price;

9. List of at least three (3) references for which similar projects were conducted, including name, company, title, phone number and email address, and a brief description of the project including the start and end dates;
10. The name and contact information of the person in Bidder's firm who would be the official contact person for any contractual relationship.
11. Fully executed forms as provided in Appendix C - Bid Forms.

10. RFP Schedule

FMPA's timetable for this RFP process is shown below. Note that the dates shown are only estimates and may be modified at any time by FMPA.

Public Notice/Distribution of RFP	July 13, 2021
Sealed Proposals Due Date	August 25, 2021
Notice of Award	September 8, 2021

11. Evaluation

The proposals will be evaluated based on information provided by each proposer by the Proposal Due Date. No additional data will be considered after the Proposal Due Date, except for clarifications requested by FMPA. FMPA will evaluate the proposals in terms of cost and other quantitative and non-quantitative factors.

Selection and rejection of proposals and notification of proposers at all stages will remain entirely with FMPA's discretion. FMPA intends to notify proposers not selected under this solicitation within a reasonable amount of time.

12. Performance Bond/Surety

Neither a bid nor a performance bond or surety is required pursuant to this RFP.

13. Budgetary Constraints

The Florida Municipal Power Agency reserve the right to reduce or increase the quantity, retract any item from the bid, or upon notification, terminate entire agreement without any obligations or penalty based upon availability of funds.

14. Interpretations and Addenda

All questions regarding interpretation of this RFP, technical or otherwise, must be submitted in writing to the following:

By E Mail: *sharon.samuels@fmpa.com*

By Fax: Ms. Sharon Samuels
(407) 355 - 5796

By Mail or Courier: Ms. Sharon Samuels
Florida Municipal Power Agency
8553 Commodity Circle
Orlando, Florida 32819

Only written responses provided by FMPA to proposers' questions will be considered official. A verbal response by FMPA will not be considered an official response.

Written responses to questions and requests for interpretations will be provided to all potential proposers. Copies of all addenda issued in connection with this RFP may be sent to all potential proposers.

15. Errors, Modifications or Withdrawal of Proposal

Each proposer should carefully review the information provided in the RFP prior to submitting a response. The RFP contains instructions which must be followed by all proposers. Modifications to proposals already received by FMPA will only be accepted prior to the Proposal Due Date. Proposals may be withdrawn by giving written notice to FMPA prior to the Proposal Due Date.

16. Proprietary Confidential Business Information

All proposals shall become property of FMPA. FMPA will not disclose to third parties any information that is clearly labeled "Proprietary Confidential Business Information" in a proposal unless, in the opinion of counsel for FMPA, such disclosures are required by law or by order of the court or government agency having appropriate jurisdiction. Each page of Proprietary Confidential Business Information must be clearly labeled "PROPRIETARY CONFIDENTIAL BUSINESS INFORMATION" at the top of the page. FMPA reserves the right to disclose information contained in proposals to its consultant(s) for the sole purpose of assisting in the proposal evaluation process. FMPA will require the consultant(s) to maintain the confidentiality of the document.

17. Default and Damages Provisions

FMPA will negotiate standard terms and conditions for default and damages with the awarded Contractor(s). All proposers are requested to include proposed default and damages provisions in their proposals.

18. Public Entity Crimes Statement

Pursuant to Section 287.133(2)(a), FLORIDA STATUTES, all proposers should be aware of the following:

"A person or affiliate who has been placed on the convicted vendor list following a conviction for a public entity crime may not submit a bid on a contract to provide any goods or services to a public entity, may not submit a bid on a contract with a public entity for the construction or repair of a public building or public work, may not submit bids on leases of real property to a public entity, may not be awarded or perform work as a contractor, supplier, subcontractor, or consultant under a contract with any public entity, and may not transact business with any public entity in excess of the threshold amount provided in Section 287.017, for CATEGORY TWO for a period of 36 months from the date of being placed on the convicted vendor list."

19. Collusion

By offering a submission pursuant to this RFP, the proposer certifies the proposer has not divulged, discussed, or compared his proposal with other proposers and has not colluded with any other proposer or parties to this proposal whatsoever. Also, the proposer certifies, and in the case of a joint proposal, each party thereto certifies, as to his own organization, that in connection with this proposal:

1. Any prices and/or cost data submitted have been arrived at independently, without consultation, communication, or agreement for the purpose of restricting competition,

as to any matter relating to such prices and or cost data, with any other proposer or with any competitor

2. Any prices and/or cost data quoted for this proposal have not knowingly been disclosed by the proposer and will not knowingly be disclosed by the proposer prior to the scheduled opening directly or indirectly to any other proposer or to any competitor
3. No attempt has been made or will be made by the proposer to induce any other person or firm to submit or not to submit a proposal for the purpose of restricting competition
4. The only person or persons interested in this proposal, principal or principals is/are named therein and that no person other than therein mentioned has any interest in this proposal or in the contract to be entered into and
5. No person or agency has been employed or retained to solicit or secure this contract upon an agreement or understanding for a commission, percentage, brokerage, or contingent fee excepting bona fide employees or established commercial agencies maintained by the Proposer for the purpose of doing business.

20. Drug Free Workplace

A Drug-Free Workplace Statement must be completed, signed, and returned prior to award of proposal. This form will be used whenever two or more proposals that are identical with respect to price, quality, delivery, and service are received; a proposal received from a business that certifies that it has implemented a drug-free workplace program shall be given preference in the award process.

21. Definitions

The words and terms defined in this document shall have the following meanings as used throughout.

ACCEPTANCE – Written acknowledgement by the FMPA and authorized representative that the Work has been completed in a manner consistent with the terms, conditions and specifications of a Contract or Purchase Order.

CONTRACTOR – The business entity (and its affiliates and authorized assigns), which has been awarded by FMPA or executed a contract with FMPA shall include any and all subcontractors, affiliates and authorized assigns that provide or perform any or all of the Work. This entity may also be referred to as the Contractor, successful bidder, or successful proposer.

PARTICIPANT CONTRACT – The aggregation of all documents that constitute the binding agreement between the Contractor and FMPA. The Participant Contract may include but shall not be limited to The Award or Agreements that result from this solicitation, Blanket Orders, Purchase Orders, Order Releases, and all attachment agreements.

PURCHASE ORDER (PO) – A Work authorization, issued by FMPA or an FMPA Member, which is issued subject to the terms and conditions of the Award or Agreement. The term “Purchase Order” shall also include “blanket order

releases” and any other ordering methodology agreed to in writing by FMPA and Contractor.

WORK – Labor, materials, supplies, equipment, goods, and services including any related documentation, software, reports, testing, transport, administration, management, tools and any and all other requirements to be furnished or performed by Contractor under this Agreement and/or a Participant Contract together with all other additional necessities that are not specifically recited in this Agreement or Participant Contract but which could be reasonably inferred as necessary to complete all obligations and fully satisfy the intent of this Agreement and/or a Participant Contract.

22. Force Majeure

FMPA or FMPA Members shall not be liable in any way to the vendor as a result of an event, circumstance or act of a third party that is beyond a party’s reasonable control (e.g. an act of God, and act of the public enemy, an act of a government entity, strikes or other labor disturbances, hurricanes, earthquakes, fires, floods, epidemics, embargoes, war and riots).

23. Entire Contract

These General Terms and Conditions, the Master Agreement between FMPA and the selected Contractor(s), and the Purchase Order (PO) for which they are being provided (including attachments thereto) constitute the entire agreement between FMPA and the Contractor.

24. Acceptance of Services and Work Product

The Product or Services shall be subject to FMPA and authorized staff’s inspection at any time. FMPA may reject Product/Services within a reasonable time after completed, if such Product/Services do not comply with the requirements of the Purchase Order or the specifications for the Product/Service. The making or failure to make any inspection of, or payment for or acceptance of Product/Service shall in no way impair FMPA’s right to reject or revoke its acceptance of nonconforming Product/Service, or to avail itself of any other remedies to which FMPA may be entitled, notwithstanding FMPA’s knowledge of the nonconformity, its substantiality or ease of discovery.

Final acceptance of the Services and Work Product for purposes of the Purchase Order shall be the date upon which FMPA confirms that all Services and Work Product have been completed in accordance with the terms of the Purchase Order (“Final Acceptance”).

25. Site Access Conditions

FMPA and authorized staff shall provide Contractor access to the Facility as necessary to perform the Work or Services. Access shall be subject to Contractor’s obligation to comply with the following conditions:

1. Contractor shall confine its activities to only those portions of the Facility necessary for performance of the Services.
2. Contractor shall take all safety measures reasonably necessary to protect FMPA and FMPA property, its permittees and licensees and the property of each, from injury or damage caused by or resulting from the performance

of Services. Contractor shall follow any and all safety and security procedures established by FMPA for the Facility. In the event of a security emergency, FMPA and its Members may deny Contractor access to a Facility or request that Contractor leave the Facility.

3. Contractor shall maintain all required insurance coverage's set forth in Section 26 at all times during the term of the Purchase Order.
4. Contractor's performance of Services shall not interfere with the use, occupancy or enjoyment of the Facility by FMPA and its Members.
5. No work or activity performed as part of the Services shall cause FMPA and its Members to be in violation of any requirement of law nor shall Contractor or any agent, employee or representative violate any federal, state or local laws while performing Services.
6. All Services shall be performed in a manner that will not damage the Facility and Contractor shall promptly notify FMPA and shall be responsible for the cost of repairing any such damage should it occur.
7. FMPA rules on maintaining a drug-free workplace shall be strictly followed and enforced by Contractor with respect to all of its employees or subcontractors and none of Contractor's employees, subcontractors, agents or representatives shall be permitted to use non-prescription drugs or alcohol at any FMPA and its Member Facility.

26. Required Insurance

The Contractor shall acquire and maintain at all times during the performance of Services the insurance coverage set forth below. Contractor shall furnish FMPA a copy of the insurance certificate. Additional information on insurance requirements are noted in Appendix B, page 5.

The liability limits shall not be less than:

Workers' Compensation Statutory

Commercial General Liability \$500,000

Automobile Liability \$500,000

Product Liability as set forth in the Purchase Order, if any;

Pollution Insurance as set forth in the Purchase Order, if any;

27. Termination for Default

Any failure by Contractor to perform or comply with the terms and conditions of the Purchase Order which continues for ten (10) calendar days after written notice from FMPA to Contractor demanding that such failure to perform be cured, shall be deemed an event of default by Contractor. Upon the occurrence of any such event of default, FMPA may terminate the Purchase Order and pursue any remedies available at law or in equity.

28. Termination for Convenience

FMPA shall have the right in its sole discretion to terminate by written notice, in whole or in part, the Purchase Order for its convenience. FMPA shall pay Contractor for any Services performed under the Specifications of the Bid Package prior to the termination date.

29. Warranties

Reference Warranty section of Appendix B, page 3.

30. Hazardous Materials of Contractor

Any Hazardous Materials used by Contractor in the performance of the Services shall be packaged, shipped, handled, labeled and disposed of by Contractor in a manner that complies with all federal, state and local laws or regulations applicable to Hazardous Materials. No Hazardous Materials shall be stored by Contractor at the FMPA and its Member's Facility before, during or after the performance of Services hereunder. Contractor shall, at its expense, remove, transport and dispose of all Hazardous Materials (i) brought by Contractor to the Facility or (ii) disturbed by Contractor's performance of Services or created by Contractor's use, handling or combination of non-hazardous materials brought by Contractor to the Facility during the performance of Services. For purposes of the Purchase Order, the term "Hazardous Materials" shall mean any substance which by law requires special handling, containment or disposal, including without limitation "hazardous substances" as defined in the Comprehensive Environmental Response, Compensation and Liability Act of 1980, as amended (42 USC Sections 9601, et seq.), the Hazardous Materials Transportation Act, as amended (49 USC Sections 5101, et seq.), "hazardous wastes" as defined in the Resource Conservation and Recovery Act, as amended (42 USC Sections 9601, et seq.), "toxic substances" as defined in the Toxic Substance Control Act as amended (15 USC Section 2601 et seq.), as amended and in the regulations adopted, published, and promulgated pursuant thereto. Contractor shall be responsible for obtaining and maintaining any licenses, permits, and/or other authorizations of any kind required for the performance of the Services. Contractor shall pay all costs of such licenses, permits and authorizations and all costs and expenses incurred in obtaining and maintaining them. The Contractor shall comply with all federal, state and local laws, and rules and regulations that are applicable to the performance of the services requested by FMPA.

31. Safety and Protection

Contractor shall be solely responsible for initiating, maintaining and supervising all safety precautions and programs in connection with work under this RFP. Contractor shall take all necessary precautions for the safety of, and shall provide the necessary protection to prevent damage, injury or loss to:

1. All persons on the site who may be affected by the project work;
2. All Work and materials and equipment to be incorporated therein, whether in storage on or off of the project site; and
3. Other property at the site or adjacent thereto, including trees, shrubs, lawns, walks, pavements, roadways, structures, utilities and underground facilities not designated for removal, relocation or replacement in the course of the project.

32. Subcontracted Services

Proposal should indicate which, if any, of the services to be provided would be subcontracted by the proposer to independent contractors. If work is intended to be subcontracted, BID SUBMITTAL MUST BE ACCOMPANIED BY BACKGROUND MATERIALS AND REFERENCES FOR PROPOSED SUBCONTRACTOR(S) - NO EXCEPTIONS. In addition, Contractor(s) must notify FMPA any time work will include subcontracted services. FMPA maintains the right to reject the proposed subcontractor for specific project work.

33. Control of Work and Subcontractors

Contractor shall be solely responsible for all construction means, methods, techniques, sequences, procedures, and safety programs in connection with the performance of the Work. In addition, Contractor shall be solely responsible for the engagement and management of any subcontractors used to perform any portion of the Work.

APPENDIX A
SCOPE OF WORK

**FMPA
TECHNICAL SPECIFICATIONS
CUSTOM ALUMINUM WORK BOAT & TRAILER**

This is a set of minimum specifications for the purchase of one (1); Custom Twenty-Three Foot (23') Dual Console Aluminum Work Boat and Trailer to be built in accordance within Marine Industry Standards and D.O.T. regulations with the features listed in this Bid document. Including delivery F.O.B. to the Stock Island Generation Facility located at 6900 Front St., Extended, Key West, FL, 33040.

This unit shall be built to the U. S. Coast Guard standards. It shall be equipped with the manufacturer's equipment and accessories which are included as standard and listed on the additional proposal page for the unit. No such item of equipment or accessories shall be removed or omitted for the reason that is was not specified in the bid.

Note: The awarded bidder must provide FMPA with a detailed, to scale drawing of their proposed work. FMPA must approve proposed drawing prior to commencement of construction.

**DETAIL SPECIFICATIONS – (NO EXCEPTION)
CUSTOM TWENTY THREE (23') FOOT DUAL CONSOLE ALUMINUM WORK BOAT
ALL MATERIALS TO BE MADE OF ALUMINUM WITH STAINLESS STEEL
FASTENERS/HARDWARE**

Length Over All – 23' Length, Beam – 9' Width, Sides -36" Height – Dead Rise at Transom -15 degrees

- Dual Console
- Self-Bailing Cockpit
- Automatic Bilge Pump 800 GPH
- Motor Guard
- Anchor Locker
- Front (Bow) Deck with Water Tight Storage with Recessed Lockable Handle
- Aft Deck with Water Tight Storage
- 4" D rubber bumpers w/ push knees in bow
- Stainless Steel Helm with Sea Star Hydraulic Steering
- 8 - Gang Blue Sea 12VDC Electrical Switch Panel
- Mounted Search Light
- LED Navigation Lights
- 2100 CCA Batteries with Selector Switches
- 100 Gallon Fuel Capacity
- Fuel Filter / Water Separator
- Bottom Anti-fouling Paint
- Rotational Molded Seats for both Starboard and Port Sides of Cockpit
- Anchor and Chain Rope Assembly – 200' with Thimbles and Shackles located in Front (Bow) Deck

Hull Materials:

- Bottom and transom 1/4" plate, 5086
- Sides, Floor, and Deck 3/16" plate, 5086
- Console 3/16" plate, 5086
- Fuel tank 1/4" plate, 5086
- Longitudes 3/16" x 3" x 1-1/2" bulb tee on 11' centers
- Frames 3/16" x 7" w/2" flange
- Keel 3/8" x 5"
- Push Knees 1/2" backing plate w/ 1/4" structure

CRIMPED PLATE WILL NOT BE ACCEPTED IN THE CONSTRUCTION OF THIS VESSEL*Propulsion:**

- 1 - 200 HP Four Stroke Mercury or Yamaha Marine Engine w/ Aluminum Propeller and digital gauges.
- All instruments and controls to be installed by manufacturer.

Trailer:

- D.O.T. approved Tandem Axle Aluminum Float-On Trailer with 8,400 pound gross capacity.
- Full size spare tire with rim mounted on the tongue of trailer.
- Electric brake
- LED light package with 6 pin Cole-Hersey or equivalent harness assembly and break-a-way system.
- 2 1/2" Pintle style hitch with safety chains and hooks.
- Proper tie down straps forward and aft

MISCELLANEOUS

- Must meet or exceed all Coast Guard Requirements and Regulations and provide the certification certificates to FMPA project manager.
- Unit to include all necessary safety & warning decals including lights installed.
- Structural integrity of the major components will be warranted for a minimum period of three (3) years. Manufacturer to provide warranty on all other items/equipment specified in this Bid Document and listed in vendor's proposal.
- D.O.T. Certification of finished Trailer.
- Awarded vendor must have fifteen (15) years of experience manufacturing aluminum watercraft.
- A list of three (3) references on similar project with contact information must be submitted with your proposal.
- All materials to be made of aluminum with stainless steel fasteners/hardware.

APPENDIX A CONTAINS A "SAMPLE" DRAWING OF THE CUSTOM TWENTY-THREE FOOT (23') DUAL CONSOLE ALUMINUM WORK BOAT. THIS IS ONLY AN EXAMPLE AND NOT TO SCALE.

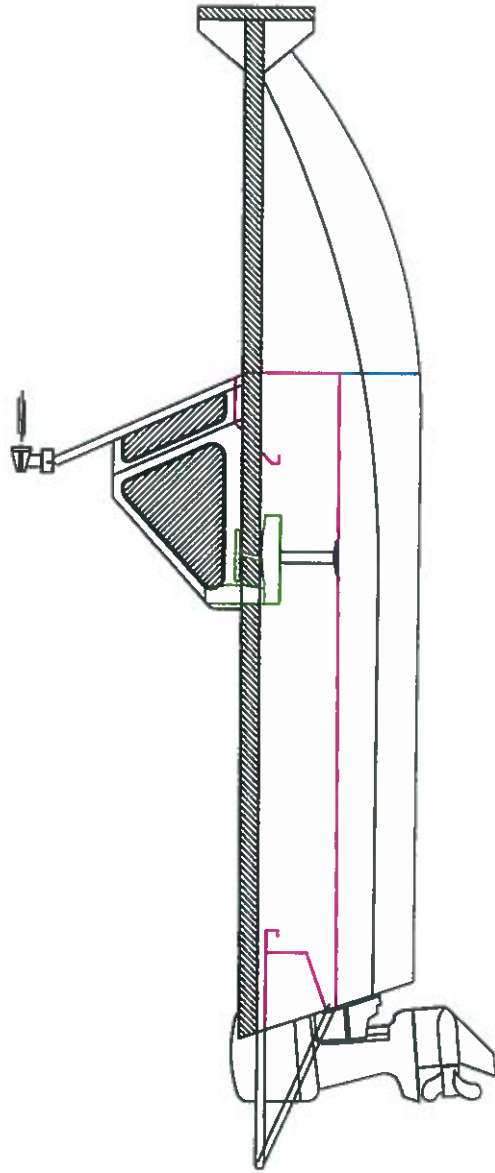
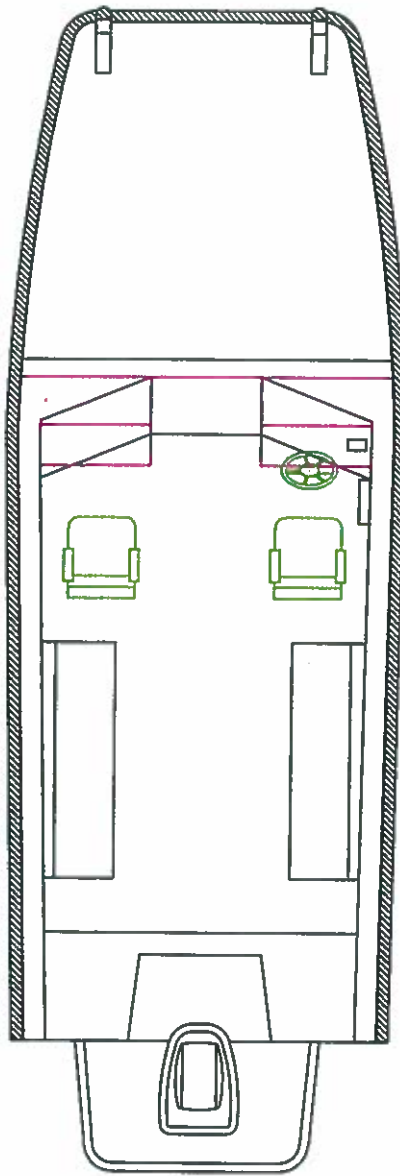

APPENDIX B
SAMPLE AGREEMENT

FLORIDA MUNICIPAL POWER AGENCY
TERMS AND CONDITIONS FOR THE PURCHASE OF GOODS AND SERVICES
(Form PO-101AR Rev 2.)

Notice: FMPA's purchase of goods and services from the Supplier is expressly conditioned on Supplier's assent to these Form PO-101AR terms and conditions (the "Terms and Conditions") which are binding on the Supplier. Any acceptance of FMPA's offer to purchase goods and services is expressly limited to acceptance of these Terms and Conditions, and FMPA expressly objects to any additional or different terms and conditions offered by the Supplier. Any order for goods and services fulfilled by the Supplier or the performance of work by Supplier shall constitute the Supplier's assent to these Terms and Conditions. These Terms and Conditions, however, do not apply to FMPA's purchase of engineering and other professional services; such purchase of engineering and other professional services shall be governed by terms and conditions separately set forth and agreed to between FMPA and the Supplier. This notice is a material part of these Terms and Conditions.

1. **Definitions.** As used in these Terms and Conditions, the terms below have the following definitions:

"**FMPA**" means the Florida Municipal Power Agency, a governmental separate legal entity created and existing under Florida Law.

"**Good(s)**" means the materials, supplies, items, and equipment covered by the purchase order and any pre-existing master agreement between FMPA and the Supplier.

"**Goods and Services**" means the Supplier's provisions of Good(s) or Services, or both, individually or together, and the Supplier's performance of the totality of its obligations as set forth in the Purchase Order.

"**Purchase Order**" means purchase order or agreement between FMPA and Supplier for the provision of Goods and Services and includes all exhibits, specifications, attachments, and these Terms and Conditions which are hereby deemed by the parties to be a material and essential part of the Purchase Order.

"**Supplier**" means a vendor, seller, supplier, materialman, outfitter, contractor, or other provider designated in the Purchase Order and includes the Supplier's employees, subcontractors, independent contractors and all other persons performing any type of work, directly or indirectly under the Supplier's direction or control, in contribution to the provision of the Goods and Services subject to the Purchase Order.

"**Services**" means the work to be performed or the services to be provided by the Supplier, or both, as described in the Purchase Order, including any technical description or proposal submitted to or issued by FMPA and related to the Purchase Order.

2. **Applicability.** The Supplier hereby agrees to sell and provide the Good(s) and perform the Services described in the Purchase Order in accordance with these Terms and Conditions and the requirements of the Purchase Order, including any specified scope of work or technical specification included in the Purchase Order.

3. **Acceptance.** The Supplier shall accept the Purchase Order in writing. If Supplier fails to accept the Purchase Order in writing, the Purchase Order and these Terms and Conditions are nonetheless applicable and binding upon the Supplier if the Supplier engages in any conduct which recognizes the existence of a contract pertaining to the subject matter hereof, including, without limitation, the shipment of Goods or commencing the performance of Services, which is deemed by the Supplier to constitute its acceptance of the Purchase Order. Any terms proposed in Supplier's acceptance of FMPA's offer that add to, vary from, or conflict with the Purchase Order and these Terms and Conditions is hereby objected to by FMPA and shall not apply. To the extent that the Purchase order might be treated as an acceptance of Supplier's prior offer, and if any of the terms of the Purchase Order are additional to or different from any terms of such offer, then the issuance of the Purchase Order by FMPA shall constitute an acceptance of such offer subject to the express condition that Supplier assent to these additional and different Terms and Conditions, which in all cases of conflict are controlling, and Supplier shall be deemed to have so assented. Any other preprinted terms and conditions affixed to any Goods or forms provided by the Supplier are hereby acknowledged and agreed to be void and of no effect.

4. **Entire Agreement.** (a) The Purchase Order sets forth the complete and final agreement between the parties with respect to the subject matter hereof, and supersedes any and all prior or contemporaneous oral or written communications relating thereto.

(b) Only if the Purchase Order is used as a release for Goods or Services under a pre-existing master agreement, then

these Terms and Conditions are deemed to supplement the provisions of such master agreement to the extent they are not inconsistent and such master agreement is hereby deemed to be appended to and form a part of the Purchase Order. In the event of any inconsistency between the terms of any pre-existing Master agreement, and these Terms and Conditions and those additionally set forth in the Purchase Order, the following order of precedence is hereby agreed: (1) the terms of the master agreement, (2) the terms on the face of the Purchase Order, and (3) these Terms and Conditions.

(c) Any reference to a proposal, quotation, or other communication given by the Supplier, unless expressly provided for in the Purchase Order to the contrary, is limited only to the description of the Goods or Services and by the terms set forth or incorporated by reference in the Purchase Order.

5. **Prices.** (a) The price(s) set forth in the Purchase Order are firm, and are not subject to increase.

(b) The Supplier represents that the price(s) charged for the Goods and Services covered by the Purchase Order are the lowest prices charged by the Supplier to buyers of a class similar to FMPA under conditions similar to those specified in the Purchase Order and the price(s) comply with the applicable government regulations in effect at the time of quotation, sale, or delivery. The Supplier agrees that any price reduction made in the Goods or Services covered by the Purchase Order within the 12 months subsequent to the placement of the Purchase Order will be applicable to the Purchase Order and FMPA. In such case, the Supplier shall issue a payment to FMPA to credit to FMPA the reduction in price from the price that FMPA has paid. If FMPA has not completed payment for the Goods and Services, the Supplier shall issue to FMPA a credit against future amounts owed under the Purchase Order.

(c) FMPA may require the Supplier to provide a performance and payment bond as an option. The bonds must be priced separately.

6. **Taxes.** FMPA is tax-exempt for most purchases. FMPA's Florida Consumer's Certificate of Exemption Number is 85-8012559814C-2. A copy of this Certificate is available upon request. However, should any federal, state, or local taxes be imposed upon or on account of such sale, the prices for the Goods and Services are hereby deemed to include all such amounts, unless otherwise expressly set forth in the Purchase Order.

7. **Invoices.** (a) All invoices shall be submitted to FMPA in duplicate and shall contain the following information: (1) Purchase Order number; (2) Purchase Order line item number, as applicable; (3) Purchase Order part number, as applicable; (4) part serial number (if serialized); (5) brief description of the Goods and Services that are the subject of the invoice; (6) unit of measure; (7) unit price; (8) item quantity; (9) extended item price; (10) total invoice value; (11) Supplier's contact information and remit-to address; (12) invoice number; (13) date prepared; and (14) payment due date. Each invoice must also be accompanied by the Supplier's waiver, in a form reasonably acceptable to FMPA, of all liens and lien rights associated with amounts set forth in the invoice, conditioned only upon FMPA's payment of such invoice, as required to keep all Good(s) free from liens and claims of lien arising out of the provisions of the Goods and Services.

(b) FMPA may invoice or set off against amounts owed to the Supplier under the Purchase Order, in its discretion, any amounts FMPA determines are owed to FMPA by the Supplier pursuant to the Purchase Order, including these Terms and Conditions.

8. **Payment.** (a) Unless otherwise expressly set forth in the Purchase Order, FMPA shall pay 100% of the uncontested Purchase Order price upon the completion of the provision of all Goods and Services within 30 days after receipt of the Supplier's invoice following the delivery and FMPA's acceptance of the Goods and Services. Payment of an invoice does not constitute acceptance of the Goods and Services and shall be subject to adjustment for errors, shortages, defects in the Goods and Services, damage to FMPA for which Supplier is partially or wholly responsible, or other failure of Supplier to meet the requirements of the Purchase Order, including any of these Terms and Conditions.

(b) If applicable, in addition to Supplier's hourly rate, FMPA shall reimburse Supplier for certain reasonable business related expenses supported by original receipt, which may include reasonable travel expenses, business mileage (paid at no more than the IRS approved rate), postage, copying, and other similar business related expenses. All requests for reimbursement of expenses will be subject to audit and approval by FMPA.

9. **Delivery and Performance.** (a) Time is of the essence, and the Goods must be received or Services performed on the date(s) and at the destination(s) set forth in the Purchase Order. If the Supplier fails to meet any such delivery or performance date, FMPA may, without limiting its other rights and remedies, direct expedited routing, charge excess costs incurred thereby to the Supplier, purchase substitute goods or services elsewhere and charge Supplier for any additional expense incurred, or cancel all or part of the Purchase Order, without further liability of FMPA.

(b) Any Services required to be performed under the Purchase Order will be performed with the skill and care which would be exercised by comparable highly qualified persons performing similar Services and exercising all diligence to perform the Services in a first class manner. If the failure to meet these standards results in deficiencies in the Services, the Supplier shall re- perform such non-conforming Services necessary to correct such deficiencies at no extra cost to FMPA. Such re-performance by the Supplier shall be done in a manner and on a schedule that is established by FMPA.

(c) If applicable, the Supplier shall provide to FMPA upon delivery of Goods all material safety datasheets and other materials reasonably required by FMPA, including without limitations, factory test reports, inspections and certifications documentation, instructions and procedures for operation and maintenance, technical specifications, shipping documentation, and other similar or FMPA-designated materials.

10. Freight; Title and Risk of Loss. (a) Unless otherwise specifically provided for, Supplier shall be responsible for all freight and delivery costs, including unloading costs, to the destination specified in the Purchase Order. All freight and delivery charges will be paid by Supplier. Notwithstanding anything else herein, Supplier shall bear all risks of loss and damage to the Goods until final acceptance by FMPA at the destination specified in the Purchase Order. Further, Supplier shall bear the same risks with respect to any Goods rejected by FMPA or as to which FMPA has revoked its acceptance, from the time of such rejection or revocation.

(b) Risk of loss, title, and ownership of the Goods and Services shall pass to FMPA upon FMPA's acceptance of the Goods and Services meeting the quantity, quality, and other requirements set forth in the Purchase Order, except that nothing prohibits FMPA from revoking such acceptance is subsequently FMPA determines any of the Goods and Services, despite the initial acceptance thereof, did not meet all requirements of the Purchase Order.

11. Inspection and Acceptance. (a) Notwithstanding any prior inspections or payments hereunder, all Goods and Services shall be subject to final inspection, which may include measurement, testing and examination, at FMPA's facility within a reasonable time (but not less than 90 days) after receipt at destination. Any inspection by FMPA does not relieve the Supplier of any obligations or liabilities under the Purchase Order.

(b) If FMPA determines that any Goods and Services delivered or performed do not meet all of the requirements of the Purchase order, FMPA shall have the right to reject such Goods and Services and return such rejected Goods to Supplier at Supplier's expense. FMPA may elect to reject the entire Goods and Services tendered even if only a portion thereof is nonconforming. If FMPA elects to accept nonconforming Goods or Services, FMPA, in addition to its other remedies, shall be entitled to an appropriate reduction in price, as reasonably determined by FMPA based upon the total Purchase Order price. Payment for any Goods or Services shall not be deemed an acceptance thereof. All Goods that fail to meet the requirements of the Purchase Order are subject to Supplier's payment of any "in and out" costs incurred by FMPA due to such failure.

(c) Acceptance of any part or portion of the Goods and Services subject to the Purchase Order does not bind FMPA to accept any future shipments nor deprive FMPA of its right to return nonconforming Goods that were previously accepted.

(d) If Services under the Purchase Order are performed on FMPA property, the Services are deemed to not be complete until all rubbish, trash, debris, and unused material due to or connected with the performance of the Services is removed and the premises are left in a safe, neat, and reasonably clean condition.

12. Warranty. (a) Supplier warrants that all Goods and Services furnished under the Purchase Order are: (1) be free from known, apparent, latent and inherent defects in workmanship, material, manufacture, and design (where design is the Supplier's responsibility); (2) comply with the requirements of the Purchase Order in all respects and any samples and warranties furnished by the Supplier; (3) be merchantable and safe for use, and fit and sufficient for the use intended by FMPA; (4) be free and clear of any lien, security interest, or other adverse claim against title; and (5) not infringe, including without limitation their sale or use alone or in combination, any United States or foreign patents, trademarks, trade secrets, copyrights, or proprietary rights of any third party.

(b) The foregoing warranties are in addition to all other warranties, expressed or implied, and shall survive any delivery, inspection, acceptance, and payment by FMPA.

(c) Supplier's warranties shall be effective for the period of time either (1) as set forth in the Purchase Order expressly, or (2) two years from the date of FMPA's final acceptance, whichever is greater plus an additional two (2) years from any warranty repair with the total period not to exceed four (4) years from the date of FMPA's final acceptance.

(d) If any of the Goods and Services furnished under the Purchase Order do not meet the warranties described in these Terms and Conditions or otherwise, FMPA may, at its option: (1) require the Supplier to correct, at no cost to FMPA, any defective or nonconforming Goods and Services by repair or replacement; or (2) return such defective or nonconforming Goods at the Supplier's expense to the Supplier and recover from the Supplier the price for such defective or nonconforming Goods and FMPA's related costs to determine such defect or nonconformance, for FMPA's return shipping costs to the Supplier, and for FMPA's acquisition and installation of replacement Goods meeting FMPA's requirements; (3) correct the defective or nonconforming Goods and Services itself and charge the Supplier for all costs and expenses incurred by FMPA related to such correction; or (4) accept the defective or nonconforming Goods and Services at a reduced price, as reasonably determined by FMPA based upon the total Purchase Order price. In all cases, for Goods and Services that do not meet the warranties described in these Terms and Conditions or otherwise, the Supplier shall be responsible for the costs of removal and reinstallation. Also, since the Goods and Services may be part of and operating power plant – the timing of repairs will in all cases be at FMPA's convenience.

13. **Changes.** FMPA reserves the right at any time to change the requirements of the Purchase Order and these Terms and Conditions in writing, and if such change causes an increase or decrease in price or delivery of the Goods or Services, an equitable written adjustment shall be made. Any price changes must be agreed to in writing at least 60 days prior to becoming effective. Any such change, modification, change order, or constructive change must be reasonable for the completion of the Services.

14. **License.** To the extent that the Supplier or third parties retain ownership rights in materials delivered with the Goods, or upon which any work product is based, the Supplier hereby grants to FMPA an irrevocable, worldwide, non-exclusive, royalty-free right and license to make, have made, modify, use, distribute, publicly perform or display, sell, offer to sell, and import such materials. Supplier hereby warrants that it owns or has acquired rights in all such intellectual property necessary to grant the licenses and intellectual property rights set forth in this provision.

15. **Liens.** As a governmental legal entity subject to Florida law, FMPA's property (real and personal) is not subject to lien or other security interests. The Supplier hereby acknowledges the foregoing and covenants to not attempt to nor permit the attempt to impose or attach a lien on FMPA's property by the Supplier associated with the Goods and Services purchased by FMPA under the Purchase Order.

16. **Indemnity.** (a) The Supplier shall defend, indemnify, and hold FMPA and its members, officers, directors, employees, agents, successors, and assigns harmless from and against any and all claims, suits, actions, liabilities, losses, costs, reasonable attorneys' fees and costs, expenses, judgments or damages, whether ordinary, special, or consequential arising directly or indirectly from or in connection with (1) the acts, negligence, omissions, or willful misconduct of Supplier; (2) the Goods or Services supplied; (3) a breach of any of Supplier's warranties or any other term or condition of the Purchase Order, including these Terms and Conditions; (4) the Supplier's negligent, unauthorized, or wrongful acts or omissions with regard to the transportation, use, handling, disposal, processing, or installation of hazardous materials; (5) a claim that any of the Goods and Services furnished by the Supplier infringe upon or misappropriate any patent, copyright, trademark, trade secret, or other intellectual property interest of another; (6) a claim of any lien, security interest, or other encumbrance made by a third party that is related to the Purchase Order; and (7) Supplier's violation of federal or state law, regulation, rule, permit, statute, or ordinance.

(b) It is understood and agreed that each party has an affirmative duty to promptly notify the other party in writing of any claims, demands, or suits brought or made against such notifying party with respect to its performance pursuant to the Purchase Order. FMPA may permit the Supplier, in FMPA's discretion, to settle any claim or suite indemnified by the Supplier hereunder, with

the written approval of FMPA and agrees, to the extent permissible by law, that it may permit the complete control of such defense by the Supplier. Any settlement offer negotiated by the Supplier pursuant to this indemnity provision shall, prior to being submitted to an adverse third party, be (1) a *bona fide* offer of settlement that releases with prejudice all claims and liabilities against FMPA, its members, directors, officers, agents, representatives, consultants, independent contractors, and employees, arising out of the claim or suit for which indemnity is sought; (2) made in good faith by the Supplier; (3) discussed, reviewed, and approved in writing by FMPA; and (4) not include any terms or conditions which impose on FMPA, its members, directors, officers, agents, representatives, consultants, independent contractors, and employees any obligation, legal or otherwise, to perform or refrain from any act which would have a legal, financial, or operational impact to FMPA and which would not be reimbursed by the Supplier as part of the proposed settlement.

(c) To the extent permissible by law, and deemed appropriate in the sole discretion of FMPA, FMPA its members, directors, officers, agents, representatives, consultants, independent contractors, and employees shall cooperate fully with the Supplier and its legal representatives in the investigation and defense of any claims or suits covered by this indemnity provision.

17. **Insurance.** (a) If required by FMPA and expressly stated in the Purchase Order, Supplier shall carry and maintain insurance coverage satisfactory to FMPA to cover its obligations in the Purchase Order, including without limitation, the following insurance with the respective minimum limits per occurrence:

- (1) Commercial General Liability - \$500,000;
- (2) Workers' Compensation - statutory;
- (3) Business Automobile Liability - \$500,000;
- (4) Product Liability Coverage - as set forth in the Purchase Order, if any; and
- (5) Pollution Insurance and Builder's All Risk - as set forth in the Purchase Order, if any.

(b) Supplier shall provide FMPA with a certificate evidencing compliance with the above requirements of subsection (a) and naming FMPA and the other entities specified in the Purchase Order (which in any event shall include the owner or any FMPA joint-owner(s) of the facility for or at which the Supplier is providing the Goods and Services) as an additional insured, except on the worker's compensation policy. Supplier shall provide FMPA with no less than 10 days prior notice of cancellation of any such insurance. At no time shall Supplier be without insurance in the above amounts during any performance related to the Purchase Order, which is deemed to be a material default under these Terms and Conditions.

18. **Termination.** (a) FMPA may, at any time, terminate the Purchase Order, in whole or in part, without cause, upon written notice to the Supplier. Upon any such termination the Supplier shall, to the extent specified by FMPA, stop all work on the Purchase order, and cause its suppliers and subcontractors to stop work. The Supplier's charges for any such termination of the Purchase Order are limited to actual non-recoverable costs incurred by the Supplier that the Supplier can demonstrate were properly incurred prior to the date of termination. In no event shall FMPA be obligated to reimburse Supplier for Good(s), inventory, or Services in excess of those required to meet FMPA's delivery schedule for binding forecasts. In no event shall such reimbursement include anticipated profits or revenue or other economic loss for undelivered Good(s) or unperformed Services.

(b) FMPA may delay the Supplier's performance for any reason upon written notice to the Supplier. If FMPA delays performance for more than three months and either FMPA or the Supplier elects to terminate the Purchase Order because of such delay, the Supplier's sole remedy shall be reimbursement for actual non-recoverable costs incurred by the Supplier that the Supplier can demonstrate were properly incurred prior to the date of termination. In no event will FMPA reimburse Supplier for Good(s), inventory, or Services in excess of those required to meet FMPA's delivery schedule for binding forecasts. In no event shall such reimbursement include anticipated profits or revenue or other economic loss for undelivered Good(s) or unperformed Services.

(c) FMPA may terminate this PO, in whole or in part, if Supplier: (1) is in material default of the Purchase Order; (2) fails to make delivery of the Good(s) or perform the Services within the time specified in the Purchase Order; (3) fails to replace or correct defective Goods and Services in accordance with the provisions of the Purchase Order, including these Terms and Conditions; (4) fails to perform any other provision of the Purchase Order or so fails to make progress as to endanger performance in accordance with its terms; or (5) becomes insolvent, files or has filed against it a petition in bankruptcy, or makes an assignment for the benefit of creditors. In the event of cancellation pursuant to this clause, FMPA may procure similar Goods or Services elsewhere by purchase order or otherwise and the Supplier shall be liable to FMPA for all of its excess costs.

(d) Any such termination shall not relieve the Supplier from any liability under the Purchase Order.

19. **Limitation of FMPA's Liability.** In no event shall FMPA be liable for special, incidental, or consequential damages or lost profits of the Supplier. Any action resulting from any breach on the part of FMPA as to the Good(s) delivered or Services performed under the Purchase Order must be commenced within one (1) year after such breach.

20. **Remedies.** FMPA's remedies are cumulative, and remedies herein specified do not exclude any remedies allowed by law or in equity. Waiver of any breach shall not constitute waiver of any other breach of the same or any other provision.

21. **Compliance with Laws.** Supplier warrants that all Goods and Services will be produced or performed in compliance with all applicable federal, state, and local laws, rules, and regulations, including without limitation:

- (1) the Environmental Protection Agency Toxic Substances Control Act's reporting regulation and any and all pre-manufacturing reporting required with regard to the Good(s), or any of the Good(s)' constituent ingredients, covered by the Purchase Order;

- (2) applicable state hazardous materials regulations in shipping the Good(s) covered by the Purchase Order;
- (3) the Occupational Safety and Health Act of 1970;
- (4) the Resource Conservation and Recovery Act, and the Immigration Reform and Control Act of 1986 (“**IRCA**”) and the IRCA’s implementing regulations as they pertain to any and all employees employed by Supplier in connection with performance hereunder.

Any provisions required thereby to be included herein shall be deemed to be incorporated by reference.

22. **Governing Law.** The validity and interpretation of the Purchase Order and the rights and obligations of the parties shall be governed and construed in accordance with the laws of the State of Florida without regard for any conflicts of law provisions that might cause the law of other jurisdictions to apply. All controversies, claims, or disputes arising out of or related to the Purchase Order or any agreement, instrument, or document contemplated by the Purchase Order must be brought exclusively in the County or Circuit Court for Leon County, Florida, or the United States District Court sitting in Tallahassee, Florida, as appropriate. The parties consent to and agree to submit to the personal jurisdiction of such courts. Each of the parties hereby waives, and agrees not to assert in any such controversy, claim, or dispute, to the fullest extent permitted by applicable law, any argument or claim that: (1) such party is not personally subject to the jurisdiction of such courts, (2) such party and such party’s property is immune from any legal process issued by such courts, or (3) any litigation or other process commenced in such courts is brought in an inconvenient forum.

23. **Independent Contractor.** In all matters relating to the Purchase Order, the Supplier is and will be deemed to be acting as an independent contractor of FMPA. The Supplier is not an employee, agent, partner, or representative of FMPA. The Supplier shall conduct its business under its own name as an independent contractor, and is hereby expressly prohibited from holding itself out as an employee, agent, partner, or representative of FMPA. It is agreed that any person employed by the Supplier to perform its obligations under the Purchase order is not and will not be deemed to be an employee of FMPA, and Supplier and Supplier’s employees, suppliers, subcontractors, agents, or representatives shall not be, nor represent themselves to be, officers, employees, agents, or representatives of FMPA and shall not bind, nor attempt to bind, FMPA to any agreement, liability, or obligation of any nature. Supplier agrees to pay, and hereby accepts full and exclusive liability for the payment of, any and all contributions and taxes for unemployment compensation or disability insurance or old age pension or annuities, and all similar provisions now or hereafter imposed by any federal or state governmental authority, which are imposed with respect to or measured by wages, salaries, or other compensation paid by the Supplier to persons employed by the Supplier; and the Supplier further agrees to indemnify and save FMPA harmless against any and all such liability or claims thereof.

24. **Force Majeure.** Neither party shall be liable for failure to perform under the Purchase Order if such failure to perform arises out of causes beyond the reasonable control and without the fault or negligence of the non- performing party (“**Force Majeure**”). Such causes may include, but are not limited to, acts of God or public enemy, wars, riots, fires, floods, explosions, epidemics, quarantine restrictions, freight embargoes, water shortages, and unusually severe weather. However, “Force Majeure” SHALL NOT MEAN NOR INCLUDE the negligence, gross negligence, or willful malfeasance of a party or any of its directors, officers, agents, representatives, independent contractors, or employees during the performance of the Purchase Order. This provision shall become effective only if the party failing to perform notifies the other party orally within 24 hours and provides written confirmation within two business days of the extent and nature of the problem, limits delay in performance to that required by the event, and takes all reasonable steps to minimize delays. This provision shall not be effective unless the failure to perform is beyond the reasonable control of the non-performing party. It is understood and agreed that FMPA shall not be liable to any other party for any damage occasioned by Force Majeure.

25. **Assignability and Subcontracting.** The Purchase Order is binding upon and inures to the benefit of the parties and their respective successors and permitted assigns. Notwithstanding the foregoing, neither the Purchase Order nor any interest in the Purchase Order may be assigned, delegated, or otherwise transferred by the Supplier except upon the prior written consent of FMPA, and any assignment or transfer without such consent shall be void and of no effect. The Supplier shall not appoint any subcontractor or non-employee to carry out its obligations under the Purchase Order without the prior written consent of FMPA. In any event, even with FMPA’s consent, the Supplier shall remain liable for the performance of all such obligations and shall ensure that any permitted subcontractor or non-employee reads and understands the terms of the Purchase Order and that the Goods and Services are provided in accordance with all requirements. FMPA may assign its rights or obligations under the Purchase Order to any FMPA affiliate or successor without Supplier’s consent.

26. **Survivorship.** All provisions, representations, and warranties contained in the Purchase Order, including in these Terms and Conditions, which by their nature are required or intended to be observed or performed after termination or completion of

the Purchase Order are hereby intended by the parties to survive its termination or completion.

27. **Notices.** (a) Each party giving or making any notice, request, demand, or other communication (each, a “notice”) pursuant to this agreement shall give the notice in writing, unless otherwise expressly permitted in this agreement, and shall use one of the following methods of delivery, each of which for purposes of this agreement is a writing: (1) personal delivery; (2) registered or certified mail, in each case, return receipt requested and postage prepaid; (3) nationally recognized overnight courier, with all fees prepaid; (4) electronic mail with electronic confirmation of the addressee opening the electronic mail (*i.e.*, read receipt) or (5) facsimile.

(b) Each party giving a notice shall address the notice to the appropriate person at the receiving party (the “Addressee”) at the address listed below or to another Addressee or at another address designated by a party in a notice pursuant to this section 27:

If to FMPA: Florida Municipal Power Agency
8553 Commodity Circle
Orlando, Florida 32819-9002
Attention: Chief Operating Officer
Facsimile No.: (407) 355-5794
Email: ken.rutter@fmpa.com
david.schumann@fmpa.com
Telephone No. (for verification purposes only): (407) 355-7767

With a required copy to: Florida Municipal Power Agency
Office of the General Counsel
2061-2 Delta Way (32303-4240)
Post Office Box 3209
Tallahassee, Florida 32315-3209
Attention: Purchase Order Terms and Conditions
Facsimile No.: (850) 297-2014
Email: jody.lamar.finklea@fmpa.com
Telephone No. (for verification purposes only): (850) 297-2011

If to the Supplier: As provided in the Purchase order.

(c) Except as provided else-where in this agreement, a notice is effective only if the party giving or making the notice has complied with subsections (a) and (b) and if the Addressee has received the notice. A notice is deemed to have been received as follows:

- (1) If a notice is delivered in person, or sent by registered or certified mail, or nationally recognized overnight courier, upon receipt as indicated by the date on the signed receipt.
- (2) If a notice is sent by facsimile, upon receipt by the party giving or making the notice of an acknowledgment or transmission report generated by the machine from which the facsimile was sent indicating that the facsimile was sent in its entirety to the Addressee’s facsimile number.
- (3) If the Addressee rejects or otherwise refuses to accept the notice, or if the notice cannot be delivered because of a change of address for which no notice was given, then upon the rejection, refusal, or inability to deliver.
- (4) Despite the other clauses in this subsection (c), if any notice is received after 5:00 p.m. on a business day where the Addressee is located, or on a day that is not a business day where the addressee is located, then the notice is deemed received at 9:00 a.m. on the next business day where the Addressee is located.

28. **Public Records.** All documents submitted and received by FMPA may become public records and FMPA shall treat them as subject to the Florida Public Records Law, including chapter 119, Florida Statutes.

29. **Enforcement.** In the event that either party is required to enforce the Purchase Order by court proceedings or otherwise, the prevailing party shall be entitled to recover all fees and costs incurred, including reasonable attorney's fees and costs, for cost of investigation, trial, alternative dispute resolution, cost of settlement, and/or appellate proceedings.

30. **Interpretation.** Each reference to the Purchase Order in these Terms and Conditions always includes these Terms and Conditions as a material part of the Purchase Order, whether or not the language "including these Terms and Conditions" or similar language is provided.

31. **General Provisions.** (a) In the event that any of the terms, covenants or conditions of the Purchase Order, or the application of any such term, covenant or condition, shall be held invalid as to any person or circumstance by any court having jurisdiction under the circumstances, the remainder of the Purchase Order and the application of its terms, covenants or conditions to such persons or circumstances shall not be affected by that invalidity.

(b) Except as provided in section 13, no amendment to the Purchase Order is valid unless mutually agreed and signed by both parties.

(c) The Purchase Order reflects the negotiated agreement of the parties. Accordingly, the Purchase Order, including these Terms and Conditions, is to be construed as if both parties jointly prepared it, and no presumption shall be made as to whether one party or the other prepared the Purchase Order for purposes of interpreting or construing any of the provisions of the Purchase Order or otherwise.

(d) The headings provided in the Purchase Order, including these Terms and Conditions, are for convenience only and do not affect its meaning.

(e) The Purchase Order may be executed in counterparts, each of which is deemed to be an original, but all of which together shall constitute one and the same instrument.

**APPENDIX C
BID FORMS**

**PROPOSAL TO FURNISH AND DELIVER
CUSTOM ALUMINUM WORK BOAT AND TRAILER
FOR THE FLORIDA MUNICIPAL POWER AGENCY**

I have carefully examined the RFP, Terms and Conditions, Technical Specifications, Bid Forms, and any other documents accompanying or made a part of this RFP. With full knowledge and understanding of the aforesaid, I agree to abide by all conditions of this bid.

I hereby propose to furnish the materials/services specified in the RFP at the prices quoted in my proposal as indicated in the appropriate spaces on this and the attached sheet BF-2.

I certify that I am duly authorized to submit this proposal; on behalf of the vendor and that the vendor is ready, willing and able to perform if awarded the bid.

Prices quoted shall remain firm and irrevocable for a period of 120 days.

ADDENDA. The undersigned bidder acknowledges receipt of the following addenda, which have been considered in preparing this proposal (if applicable).

Number _____ Dated _____

Number _____ Dated _____

Respectfully submitted:

Company Name: _____

Signature: _____

(Authorized Representative)

(Type or Print Name of Signer)

Address: _____

E-Mail Address: _____

Telephone Number: _____

Toll Free Number: _____

Date: _____

BID FORM
Furnish & Delivery of Custom Work Boat and Trailer

BID FORM

Provide Pricing to furnish and deliver as described in the scope of work.

BOAT TOTAL PRICE _____

TRAILER TOTAL PRICE _____

DISPUTE DISCLOSURE

Answer the following questions by placing an "X" in the appropriate "YES" or "NO" box. If you answer "YES", please explain in the space provided, or via attachment.

Has your firm, or any of its officers, received a reprimand of any nature or been suspended by the Department of Professional Regulation or any other regulatory agency or professional association within the last five (5) years?

YES NO

Has your firm, or any member of your firm, been declared in default, terminated or removed from a contract or job related to the services your firm provides in the regular course of business within the last five (5) years?

YES NO

Has your firm had filed against it or filed any requests for equitable adjustment, contract claims or litigation in the past five (5) years that is related to the services your firm provides in the regular course of business?

YES NO

If yes, state the nature of the request for equitable adjustment, contract claim or litigation, a brief description of the case, the outcome or status of suit and the monetary amounts or extended contract time involved.

I hereby certify that all statements made are true and agree and understand that any misstatement or misrepresentation or falsification of facts shall be cause for forfeiture of rights for further consideration of this project:

Project: FMPA RFP# 2021-250

Firm

Date

Authorized Signature

Officer Title

Printed or Typed Name

AFFIDAVIT OF COMPLIANCE

FMPA RFP 2021-250

_____ We DO NOT take exception to any items included in the RFP.

_____ We TAKE exception as follows:

Company Name:

By:

(Authorized Person's Signature)

(Print or type name and title of signer)

Company Address:

Telephone Number:

Toll Free Number:

Fax Number:

Date:

DRUG-FREE WORKPLACE COMPLIANCE FORM

Preference shall be given to businesses with drug-free workplace programs. Pursuant to Section 287.087, Florida Statutes, whenever two or more proposals which are equal with respect to price, quality, and service are received by the State or by any political subdivision for the procurement of commodities or contractual services, a proposal received from a business that certifies that it has implemented a drug-free workplace program shall be given preference in the award process.

The undersigned proposer in conformity with Florida Statute 287.087 hereby certifies that _____ does:

(Name of business)

1. Publish a statement notifying employees that the unlawful manufacture, distribution, dispensing, possession, or use of a controlled substance is prohibited in the workplace and specifying the actions that will be taken against employees for violations of such prohibition.
2. Inform employees about the dangers of drug abuse in the workplace, the business's policy of maintaining a drug-free workplace, any available drug counseling, rehabilitation, and employee assistance programs, and the penalties that may be imposed upon employees for drug abuse violations.
3. Give each employee engaged in providing the commodities or contractual services that are under proposal a copy of the statement specified in Subsection 1.
4. In the statement specified in Subsection 1, notify the employees that, as a condition of working on the commodities or contractual services that are under proposal, the employee will abide by the terms of the statement and will notify the employer of any conviction of, or plea of guilty or nolo contendere to, any violation of Chapter 893 or of any controlled substance law of the United States or any state, for a violation occurring in the workplace no later than five (5) days after such conviction.
5. Impose a sanction on, or require the satisfactory participation in a drug abuse assistance or rehabilitation program if such is available in the employee's community, by any employee who is so convicted.
6. Make a good faith effort to continue to maintain a drug-free workplace through implementation of this section.

As the person authorized to sign the statement, I certify that the undersigned complies fully with the above requirements.

Signature

Name of Proposer

Date

STATEMENT OF NO PROPOSAL

Sharon Samuels
Florida Municipal Power Agency
8553 Commodity Circle
Orlando, FL 32819

We, the undersigned, have declined to submit a proposal on your Request for Proposals Number 2021-250, Florida Municipal Power Agency, Furnish & Delivery of Custom Aluminum Work Boat and Trailer - for the following reasons:

- We do not offer this service/product.
- Our schedule would not permit us to perform.
- Unable to meet specifications.
- Unable to meet bond requirements.
- Other

We understand that if the Statement of No Proposal letter is not executed and returned, our name may be deleted from the list of qualified proposers of the Florida Municipal Power Agency.

Company Name: _____

By: _____
(Authorized Person's Signature)

(Print or type name and title of signer)

Company Address: _____

Telephone Number: _____

Toll Free Number: _____

Fax Number: _____

Date: _____