



ADDENDUM NO 1

ADDENDUM NO 1

FLORIDA MUNICIPAL POWER AGENCY

Request for Proposal# 2026-210
June 1, 2026

FMPA Request for Proposals Number 2026-210, Transformers Life Extension Services, has changed to reflect the following additions, deletions, and/or modifications:

Item No. 1

Addition to the Scope of Work.

The scope has expanded to include transformers painting. See attachments for details.

Item No. 2

Modification to the RFP schedule.

The due date has been rescheduled to Wednesday, June 24, 2026 at 1:30PM.

All other aspects of the RFP document remain the same.

* * * * *

Transformers Life Extension Services

Scope of Work – Revision 6/1/26

Add Option: Transformer Painting

- Contractors are to provide pricing per individual transformer at the plant, including Aux Transformer #2 (although it may ultimately not be required).
- Contractor shall provide a detailed painting process and schedule. FMPA understands this work may need to be performed during a separate outage due to schedule constraints.

Supporting Information

- Attached are previous test reports related to oil samples and electrical testing.
- Attached are available outline drawings and specifications for GSU #1 and GSU #2.
 - Note: Similar information for the 13.8/4.16kV Aux Transformer #1 is not currently available.

Pricing Requirements

- For all work, contractors shall provide a price breakdown separating:
 - Material Cost
 - Labor Cost

Please see the bidform to submit pricing.

BID FORM
Transformers Life Extension Services - REVISED

BID FORM
<p>Base Bid – Transformer Life Extension Services (per transformer)</p> <p>Material Cost \$ _____</p> <p>Labor Cost \$ _____</p> <p>Provide a <u>Lump Sum Total Price</u> to furnish and deliver transformer life extension services.</p> <p>TOTAL PRICE _____</p>

Alternate options

OPTION A
<p>Option A – Perform services to all transformers under one outage vs two outages.</p> <p>TOTAL PRICE _____</p>

OPTION B
<p>Option B – Perform Transformer painting. Provide pricing per transformer.</p> <ul style="list-style-type: none"> • GSU #1 \$ _____ • Aux Transformer #1 \$ _____ • GSU #2 \$ _____ • Aux Transformer #2 <i>(include, but may not be required)</i> \$ _____

1) Per Section 39, please be sure to add any additional information that might apply to other sites.

Please also provide a time & materials rate for the project.
T&M Rates
Please include a T&M Rate Sheet for all work offered by your company.

This is a required form; please complete and include it in your submittal.

TESTING REPORTS

Orange Cogen – 2024 Outage Testing

prepared for

**Orange Cogeneration
1901 S Clear Springs Rd
Bartow, FL 33830**

prepared by

**TRC
Florida Division
Project # 624942 / 624946**

October 2024





Bent interlock arm



Bent interlock arm



Bad under voltage relay



T2 - H1 Bushing



T2 - H2 Bushing



T2 - H3 Bushing



T2 - H0 Bushing



T2 - Low Side



T2 - Top of Low side Leaking fix



52 - T2 Breaker



T1 - Aux Low Side



T1 - Aux High Side



T1 - Aux High Side



T1 GSU - Low Side

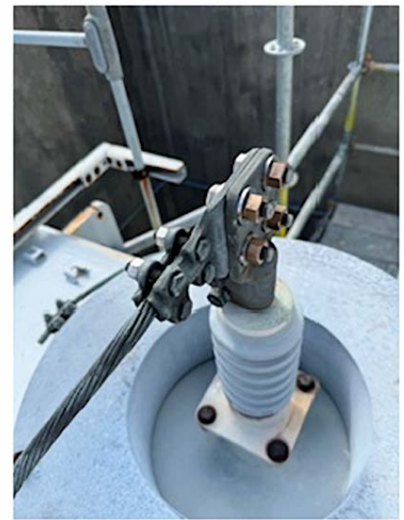

T1 - H0 Bushing

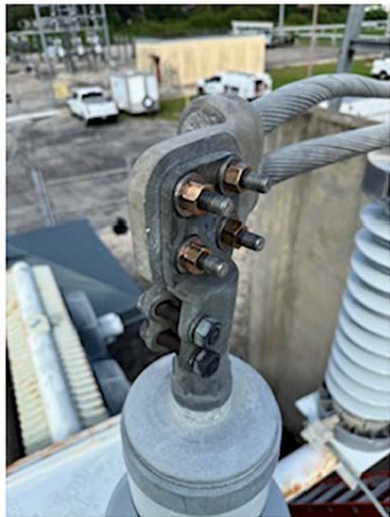

T1 - H3 Bushing



T1 - H2 Bushing



T1 - H1 Bushing

TESTING REPORTS FOR T2-GSU

624942 - T2 - GSU



Client	Orange Cogen	624942 - T2 - GSU	
Execution date	9/27/2024	Reason of the job	Routine
Tested by	Matthew Falchetti	Location	Orange Cogen
Approved by		Asset	Transformer
Report ID	4	Asset type	Three-winding
Report issue date	10/9/2024 12:15:19 PM	Asset serial number	LNL9182
Work order		Manufacturer	ABB

Summary

Performed tests	Assessment
Overall PF & CAP	Pass
Bushing H PF & CAP - C1	Pass
Bushing H PF & CAP - C2	Pass
Bushing H – Energized Collar	Pass
Exciting Current	Pass
Surge Arrester Watt Losses H	Pass
TTR H-X	Pass
TTR H-Y	Pass
DC Winding Resistance H	Pass
DC Winding Resistance X	Pass
DC Winding Resistance Y	Pass

Overall Assessment	No Faults - Passed
--------------------	--------------------

Tested by:
Matthew Falchetti / Andrew Kirk

Approved by:
Matthew Falchetti

Location & company information			
Location		Company	
Name	Orange Cogen	Company	TRC Companies
Region		Department	
Division	TRC Companies	Address	
Area		City	Lakeland
Plant	Orange Cogen	State/Province	Florida
Address	1901 S. Clear Springs Rd	Postal code	
City	Bartow	Country	United States
State/Province	Florida	Phone No.	
Postal code	33830	Fax No.	
Country	United States	E-mail	

Geo coordinates	
-----------------	--

Contact person	
Name	David Courson
Phone No. 1	
Phone No. 2	
Fax No.	
E-mail	

Comment

Transformer nameplate data			
Serial number	LNL9182	Apparatus ID	T2 - GSU
Manufacturer	ABB	Feeder	
Manufacturing year	1994	No. phases	3
Manufacturer type	SL	Vector group	YNd1d1

Comment

Low to Gound Y - 2.31 G			
Low to Gound X - 2.09 G			
	30 sec.	1 min.	10 min
High to Low X - 1.73 G	2.10 G	2.10 G	5.10 G
High to Low Y - 1.96 G	2.54 G	2.54 G	5.63 G
High to Gound - 1.68 G			

Voltage ratings			
Winding	Voltage L-L	Voltage L-N	Insul. level L-L
H	70.690 kV	40.813 kV	350 kV
X	13.800 kV	kV	110 kV
Y	13.800 kV	kV	110 kV

Power ratings		
Rated power	Cooling class	Temp. rise wind.
33.000 MVA	OA	

Current ratings at rated power			
Winding			
H	X	Y	Rated power
927.000 A	2062.000 A	2687.000 A	33.000 MVA

Short-circuit rating

Max. short-circuit current		kA		s
----------------------------	--	----	--	---

Impedances

Ref. temp.	75 °C
------------	-------

Leakage reactance H - X

Zk[%]	Base power	Base voltage	Load losses Pk	OLTC position	DETC position
%	MVA	kV	W		

Leakage reactance H - Y

Zk[%]	Base power	Base voltage	Load losses Pk	OLTC position	DETC position
%	MVA	kV	W		

Leakage reactance X - Y

Zk[%]	Base power	Base voltage	Load losses Pk	OLTC position	DETC position
%	MVA	kV	W		

Zero sequence impedance

Base power	33.00 MVA
Base voltage	72.500 kV
Description	Z0[%]
Primary	13.07 %

Others

Category	Generation
Status	In operation
Tank type	Nitrogen blanketed
Insulation medium	Mineral oil
Fluid insulation volume	9998 gals
Fluid insulation weight	lbs
Total weight	288115 lbs

Bushings nameplate data

Pos.	Serial No.	Manufact.	Manufacturer type	Man. year	Voltage L-ground	Max. system voltage	Rated current
H1	3785220394	ABB	O Plus C	1994	44.0 kV	69.0 kV	400.0 A
H2	3785220294	ABB	O Plus C	1994	44.0 kV	69.0 kV	400.0 A
H3	3785220194	ABB	O Plus C	1994	44.0 kV	69.0 kV	400.0 A
H0	2785200194	ABB		1994	15.0 kV	15.0 kV	1200.0 A
X1	8C01085406	ABB		1998	10.0 kV	15.0 kV	3300.0 A
X2	8C01085405	ABB		1998	10.0 kV	15.0 kV	3300.0 A
X3	8C01085401	ABB		1998	10.0 kV	15.0 kV	3300.0 A
Y1	8C01085402	ABB		1998	10.0 kV	15.0 kV	3300.0 A
Y2	8C01085404	ABB		1998	10.0 kV	15.0 kV	3300.0 A
Y3	8C01085403	ABB		1998	10.0 kV	15.0 kV	3300.0 A

Pos.	Insul. level LL	Cap. (C1)	PF (C1)	Cap. (C2)	PF (C2)	Insulation type	Tap type
H1	350 kV	266.00 pF	0.250 %	pF	%	Oil-impregnated paper	With potential tap
H2	350 kV	266.00 pF	0.230 %	pF	%	Oil-impregnated paper	With potential tap
H3	350 kV	272.00 pF	0.230 %	pF	%	Oil-impregnated paper	With potential tap
H0	110 kV	pF	%	pF	%	Oil-impregnated paper	Without tap
X1	110 kV	pF	%	pF	%	Porcelain dry type	Without tap

Pos.	Insul. level LL	Cap. (C1)	PF (C1)	Cap. (C2)	PF (C2)	Insulation type	Tap type
X2	110 kV	pF	%	pF	%	Porcelain dry type	Without tap
X3	110 kV	pF	%	pF	%	Porcelain dry type	Without tap
Y1	110 kV	pF	%	pF	%	Porcelain dry type	Without tap
Y2	110 kV	pF	%	pF	%	Porcelain dry type	Without tap
Y3	110 kV	pF	%	pF	%	Porcelain dry type	Without tap

Tap Changers nameplate data

DETC

Serial number	
Manufacturer	ABB
Manufacturer type	Manual
Winding	H
Tap scheme	1...N
No. of taps	5

Tap	Voltage
1	76125.0 V
2	74310.0 V
3	72500.0 V
4	70690.0 V
5	68875.0 V

Surge Arrester nameplate data

Surge arrester H1

Serial number	Manufacturer	Manufacturing year	Overall catalog no	Units in stock
668	CERAN	1994		1

Position	Serial No.	Voltage L-L	Voltage L-N	MCOV rating	Unit ID
1		kV	kV	kV	

Surge arrester H2

Serial number	Manufacturer	Manufacturing year	Overall catalog no	Units in stock
592	CERAN	1994		1

Position	Serial No.	Voltage L-L	Voltage L-N	MCOV rating	Unit ID
1		kV	kV	kV	

Surge arrester H3

Serial number	Manufacturer	Manufacturing year	Overall catalog no	Units in stock
588	CERAN	1994		1

Position	Serial No.	Voltage L-L	Voltage L-N	MCOV rating	Unit ID
1		kV	kV	kV	

Test set information

Model	Serial number	Calibration date
TESTRANO 600	LN612B	2024-07-08

CP TD12	LN574C	2024-07-27
---------	--------	------------

Global test conditions			
Weather	Clear	Humidity	94 %
Unit location	Outside	Ambient temperature	27 °C

Overall PF & CAP			
Ambient temperature	27 °C	Weather	Clear
Top oil temperature	30 °C	Humidity	94 %

Comments

--

Standard test

Block 1: injection at H

Corr. temperature	30 °C
Corr. factor	0.8

No.	Meas.	Test mode	Freq.	V out	I out	Watt losses	PF meas	PF corr	Cap. meas	Assessment
1	ICH+ICHL	GSTg-B	60.00 Hz	10.00 kV	29.86 mA	886.94 mW	0.2971 %	0.2377 %	7917.2 pF	Pass
2	ICH	GSTg-A+B	60.00 Hz	10.00 kV	18.09 mA	682.61 mW	0.3774 %	0.3019 %	4795.8 pF	Pass
3	ICHL	UST-A	60.00 Hz	10.00 kV	11.77 mA	190.77 mW	0.1621 %	0.1297 %	3121.2 pF	Pass

Block 2: injection at X

Corr. temperature	30 °C
Corr. factor	0.8

No.	Meas.	Test mode	Freq.	V out	I out	Watt losses	PF meas	PF corr	Cap. meas	Assessment
4	ICL+ICLT	GSTg-A	60.00 Hz	7.00 kV	28.83 mA	730.54 mW	0.3620 %	0.2896 %	10922.8 pF	Pass
5	ICL	GSTg-A+B	60.00 Hz	7.00 kV	20.68 mA	631.96 mW	0.4366 %	0.3493 %	7833.4 pF	Pass
6	ICLT	UST-B	60.00 Hz	7.00 kV	8.15 mA	94.21 mW	0.1651 %	0.1321 %	3089.0 pF	Pass

Block 3: injection at Y

Corr. temperature	30 °C
Corr. factor	0.8

No.	Meas.	Test mode	Freq.	V out	I out	Watt losses	PF meas	PF corr	Cap. meas	Assessment
7	ICT+ICTH	GSTg-A	60.00 Hz	7.00 kV	30.83 mA	772.80 mW	0.3581 %	0.2865 %	11679.0 pF	Pass
8	ICT	GSTg-A+B	60.00 Hz	7.00 kV	22.59 mA	665.66 mW	0.4210 %	0.3368 %	8557.3 pF	Pass
9	ICTH	UST-B	60.00 Hz	7.00 kV	8.24 mA	93.09 mW	0.1615 %	0.1292 %	3121.2 pF	Pass

Bushing H PF & CAP - C1

Ambient temperature	27 °C	Weather	Clear
Top oil temperature	30 °C	Humidity	94 %

Comments

--

Standard test

Corr. factor		1								
No.	Meas.	Test mode	Freq.	V out	I out	Watt losses	PF meas	PF corr	Cap. meas	Assessment
1	H1	UST-A	60.00 Hz	10.00 kV	0.99 mA	22.23 mW	0.0530 %	0.0530 %	261.9 pF	Pass
2	H2	UST-A	60.00 Hz	10.00 kV	0.99 mA	22.16 mW	0.2234 %	0.2234 %	263.1 pF	Pass
3	H3	UST-A	60.00 Hz	10.01 kV	1.02 mA	26.59 mW	0.2611 %	0.2611 %	269.6 pF	Pass

Bushing H PF & CAP - C2

Ambient temperature	27 °C	Weather	Clear
Top oil temperature	30 °C	Humidity	94 %

Comments

--

Standard test

No.	Meas.	Test mode	Freq.	V out	I out	Watt losses	PF meas	PF corr	Cap. meas	Assessment
1	H1	GSTg-A	60.00 Hz	2.00 kV	0.43 mA	20.52 mW	2.4082 %	2.4082 %	562.1 pF	Inv.
2	H2	GSTg-A	60.00 Hz	2.00 kV	0.42 mA	17.20 mW	2.0351 %	2.0351 %	557.5 pF	Inv.
3	H3	GSTg-A	60.00 Hz	2.00 kV	0.39 mA	8.27 mW	1.0538 %	1.0538 %	517.5 pF	Inv.

Bushing H – Energized Collar

Ambient temperature	27 °C	Weather	Clear
Top oil temperature	30 °C	Humidity	94 %

Comments

--

Standard test

No.	Meas.	Test mode	Freq.	V out	I out	Watt losses	Assessment
1	H1	UST-A	60.00 Hz	12.00 kV	0.10 mA	76.35 mW	Pass
2	H2	UST-A	60.00 Hz	12.00 kV	0.10 mA	139.79 mW	Pass
3	H3	UST-A	60.00 Hz	12.00 kV	0.10 mA	103.61 mW	Pass
4	H0	UST-A	60.00 Hz	12.00 kV	0.10 mA	716.71 mW	Pass

Test set information

Model	Serial number	Calibration date
TESTRANO 600	LN612B	2024-07-08
CP TD12	LN574C	2024-07-27

Exciting Current

Comment

--

Measurement settings

Test voltage	5 kV
Test frequency	60.00 Hz
Tap changer under test	DETC

Averaging	2
Bandwidth	±20 Hz
AvoidTestFrequency	No

Use reference voltage	No
-----------------------	----

Measurements (sorted by tap)

Tap	Phase	V out	I out	I phase	Watt losses	Reactance	Assessment
4	A	5.00 kV	132.018 mA	-60.40 °	326.066 W	32.936 kΩ	Pass
4	B	5.00 kV	101.958 mA	-60.75 °	249.093 W	42.793 kΩ	Pass
4	C	5.00 kV	131.383 mA	-60.21 °	326.359 W	33.032 kΩ	Pass

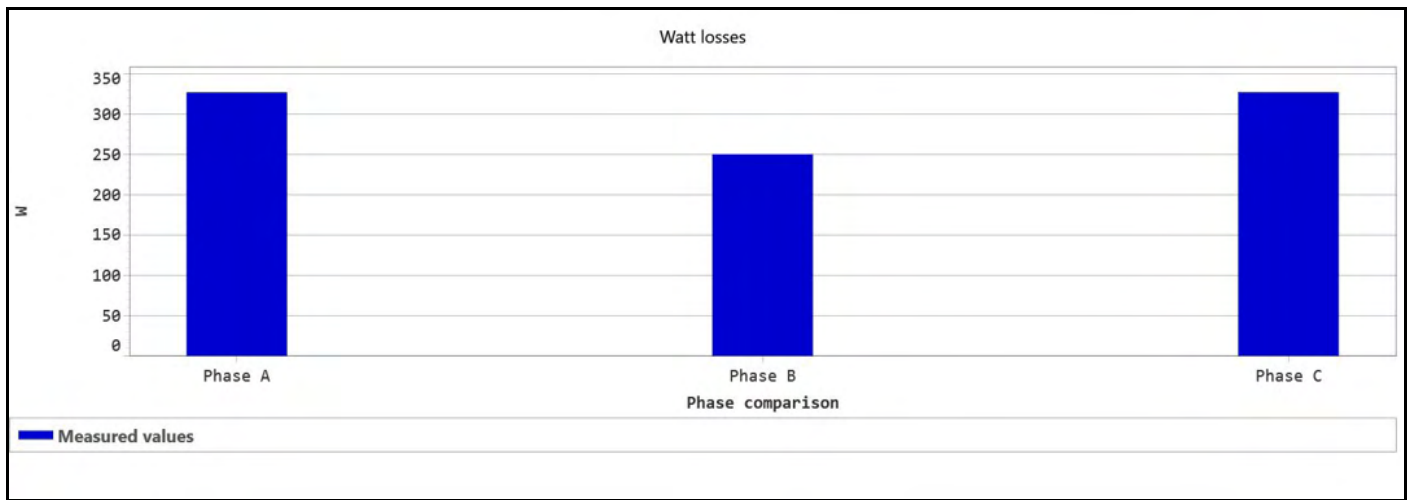
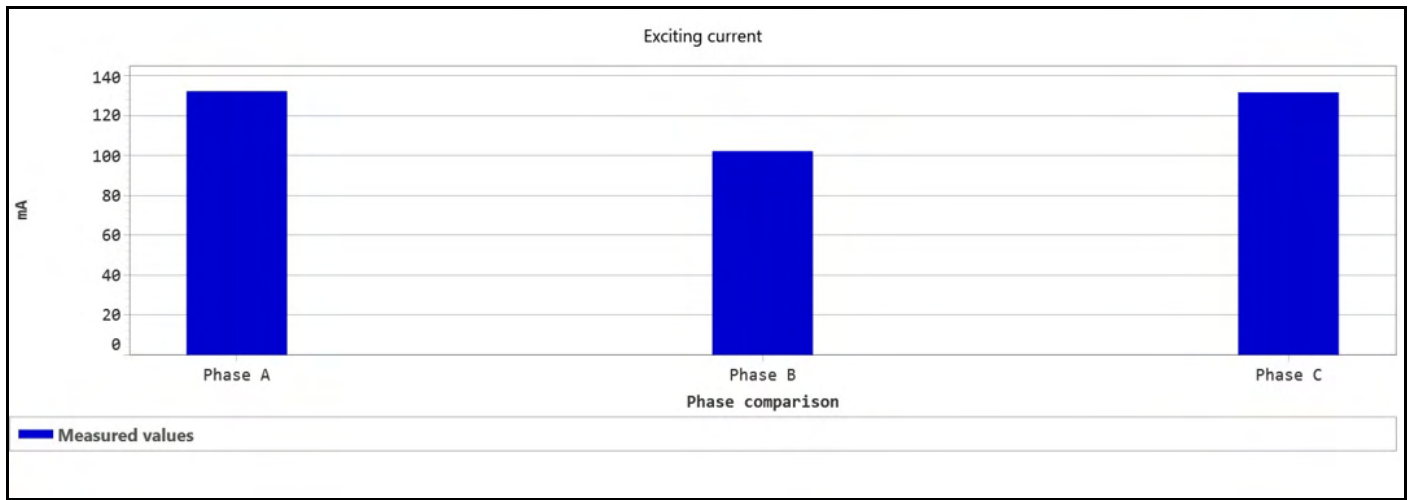

Surge Arrester Watt Losses H

Ambient temperature	27 °C	Weather	Clear
Top oil temperature	30 °C	Humidity	94 %

Comments

--

Standard test

Meas.	Position	Test mode	Freq.	V out	I out	Watt losses	Assessment
H1	1	GST	60.00 Hz	1.00 kV	0.03 mA	4.72 mW	Pass
H2	1	GST	60.00 Hz	1.00 kV	0.03 mA	3.95 mW	Pass
H3	1	GST	60.00 Hz	1.00 kV	0.03 mA	3.67 mW	Pass

Test set information

Model	Serial number	Calibration date
TESTRANO 600	LN612B	2024-07-08

TTR H-X

Comment

--

Measurement settings

Test voltage	120 V
Test frequency	60.00 Hz
Tap changer under test	DETC

Ratio	TTR*
-------	------

Measurements (sorted by tap)

<i>Tap</i>	<i>Phase</i>	<i>Nom. Ratio</i>	<i>V prim (L-L)</i>	<i>I prim</i>	<i>V sec (L-L)</i>	<i>V phase</i>	<i>TTR*</i>	<i>Ratio dev</i>	<i>Assessment</i>
4	A	2.9575	119.87 V	3.443 mA	23.36 V	210.01 °	2.9621	0.16 %	Pass
4	B	2.9575	119.88 V	3.497 mA	23.36 V	330 °	2.9623	0.16 %	Pass
4	C	2.9575	119.87 V	2.442 mA	23.36 V	90 °	2.9622	0.16 %	Pass

Test set information

Model	Serial number	Calibration date
TESTRANO 600	LN612B	2024-07-08

TTR H-Y

Comment

--

Measurement settings

Test voltage	120 V
Test frequency	60.00 Hz
Tap changer under test	DETC

Ratio	TTR*
-------	------

Measurements (sorted by tap)

Tap	Phase	Nom. Ratio	$V_{prim} (L-L)$	I_{prim}	$V_{sec} (L-L)$	V_{phase}	TTR*	Ratio dev	Assessment
4	A	2.9575	119.88 V	6.848 mA	23.36 V	210.01 °	2.9632	0.19 %	Pass
4	B	2.9575	119.88 V	5.288 mA	23.36 V	330.01 °	2.9628	0.18 %	Pass
4	C	2.9575	119.88 V	4.360 mA	23.36 V	90 °	2.9626	0.17 %	Pass

Test set information

Model	Serial number	Calibration date
TESTRANO 600	LN612B	2024-07-08

DC Winding Resistance H

Comment

--

Measurement settings

Test current	5 A	Tap changer under test	DETC
Output mode	16 A @ 113 V		
	3 ph.		
Measurement	L-N		

Winding temperature	20 °C
Reference temperature	75 °C
Temp. corr. factor (K)	1.216

Automatic result	True
Settling time (At)	5 s
Tolerance R dev	0.1 %
Recording time	200.0 ms

	A (H1 - H0)			B (H2 - H0)			C (H3 - H0)		
Tap	<i>R meas</i>	<i>R dev</i>	<i>R corr</i>	<i>R meas</i>	<i>R dev</i>	<i>R corr</i>	<i>R meas</i>	<i>R dev</i>	<i>R corr</i>
4	57.825 mΩ	0.033 %	70.322 mΩ	57.964 mΩ	0.018 %	70.490 mΩ	58.420 mΩ	0.056 %	71.045 mΩ

Test set information

Model	Serial number	Calibration date
TESTRANO 600	LN612B	2024-07-08

DC Winding Resistance X

Comment

--

Measurement settings

Test current	10 A
Output mode	33 A @ 170 V
	1 ph.

Automatic result	True
Settling time (At)	5 s
Tolerance R dev	0.1 %
Recording time	200.0 ms

A (X1 - X2)			B (X2 - X3)			C (X3 - X1)		
<i>R meas</i>	<i>R dev</i>	<i>R corr</i>	<i>R meas</i>	<i>R dev</i>	<i>R corr</i>	<i>R meas</i>	<i>R dev</i>	<i>R corr</i>
5.467 mΩ	0.210 %	5.467 mΩ	5.097 mΩ	0.049 %	5.097 mΩ	5.324 mΩ	0.456 %	5.324 mΩ

Test set information

Model	Serial number	Calibration date
TESTRANO 600	LN612B	2024-07-08

DC Winding Resistance Y

Comment

--

Measurement settings

Test current	10 A
Output mode	33 A @ 170 V
	1 ph.

Automatic result	True
Settling time (At)	5 s
Tolerance R dev	0.1 %
Recording time	200.0 ms

A (Y1 - Y2)			B (Y2 - Y3)			C (Y3 - Y1)		
<i>R meas</i>	<i>R dev</i>	<i>R corr</i>	<i>R meas</i>	<i>R dev</i>	<i>R corr</i>	<i>R meas</i>	<i>R dev</i>	<i>R corr</i>
5.968 mΩ	0.097 %	5.968 mΩ	6.124 mΩ	0.028 %	6.124 mΩ	5.284 mΩ	0.217 %	5.284 mΩ

TESTING REPORTS FOR T1-GSU

624946 - T1 - GSU



Client	624946 - T1 - GSU		
Execution date	10/2/2024	Reason of the job	Routine
Tested by	Falchetti, Matthew	Location	Orange Cogen
Approved by		Asset	Transformer
Report ID	2	Asset type	Two-winding
Report issue date	10/9/2024 12:20:53 PM	Asset serial number	MNL-9183
Work order		Manufacturer	ABB

Summary			
Low to Ground - 1.17 G			
High to Ground - 1.68 G			
	30 sec.	1 min.	10 min.
High to Low -	1.01 G	1.44 G	3.57 G

Performed tests	Assessment
Overall PF & CAP	Pass
Bushing H PF & CAP - C1	Pass
Bushing H PF & CAP - C2	Pass
Bushing H – Energized Collar	Pass
Exciting Current	Pass
Surge Arrester Watt Losses H	Pass
TTR H-X	Pass
DC Winding Resistance H	Pass
DC Winding Resistance X	Pass

Overall Assessment	No Faults - Passed
--------------------	--------------------

Tested by:
Matthew Falchetti / Andrew Kirk

Approved by:
Matthew Falchetti

Location & company information			
Location		Company	
Name	Orange Cogen	Company	TRC Companies
Region		Department	
Division	TRC Companies	Address	
Area		City	Lakeland
Plant	Orange Cogen	State/Province	Florida
Address	1901 S. Clear Springs Rd	Postal code	
City	Bartow	Country	United States
State/Province	Florida	Phone No.	
Postal code	33830	Fax No.	
Country	United States	E-mail	

Geo coordinates	
-----------------	--

Contact person	
Name	Lee Bland
Phone No. 1	
Phone No. 2	
Fax No.	
E-mail	

Comment

Transformer nameplate data			
Serial number	MNL-9183	Apparatus ID	T1 - GSU
Manufacturer	ABB	Feeder	
Manufacturing year	1994	No. phases	3
Manufacturer type	SL	Vector group	YNd1

Comment

Voltage ratings			
Winding	Voltage L-L	Voltage L-N	Insul. level L-L
H	70.690 kV	40.813 kV	350 kV
X	13.800 kV	kV	110 kV

Power ratings		
Rated power	Cooling class	Temp. rise wind.
44.000 MVA	OA	

Current ratings at rated power		
Winding		
H	X	Rated power
A	A	44.000 MVA

Short-circuit rating		
Max. short-circuit current	kA	s

Impedances	
Ref. temp.	75 °C

Leakage reactance H - X

Zk[%]	Base power	Base voltage	Load losses Pk	OLTC position	DETC position
%	MVA	kV	W		

Zero sequence impedance

Base power	44.00 MVA
Base voltage	72.500 kV
Description	Z0[%]
Primary	8.02 %

Others

Category	Distribution
Status	In operation
Tank type	Nitrogen blanketed
Insulation medium	Mineral oil
Fluid insulation volume	4828 gals
Fluid insulation weight	lbs
Total weight	150535 lbs

Bushings nameplate data

Pos.	Serial No.	Manufact.	Manufacturer type	Man. year	Voltage L-ground	Max. system voltage	Rated current
H1	3785180394	ABB	O PLUS C	1994	44.0 kV	69.0 kV	400.0 A
H2	3785180294	ABB	O PLUS C	1994	44.0 kV	69.0 kV	400.0 A
H3	3786770694	ABB	O PLUS C	1994	44.0 kV	69.0 kV	400.0 A
H0		ABB	O PLUS C	1994	15.0 kV	15.0 kV	1200.0 A
X1	8C01127901	ABB		1998	10.0 kV	15.0 kV	3300.0 A
X2	8C01127903	ABB		1998	10.0 kV	15.0 kV	3300.0 A
X3	8C01127902	ABB		1998	10.0 kV	15.0 kV	3300.0 A

Pos.	Insul. level LL	Cap. (C1)	PF (C1)	Cap. (C2)	PF (C2)	Insulation type	Tap type
H1	350 kV	266.00 pF	0.300 %	pF	%	Oil-impregnated paper	With test tap
H2	350 kV	265.00 pF	0.350 %	pF	%	Oil-impregnated paper	With test tap
H3	350 kV	265.00 pF	0.240 %	pF	%	Oil-impregnated paper	With test tap
H0	110 kV	pF	%	pF	%	Oil-impregnated paper	With test tap
X1	110 kV	pF	%	pF	%	Oil-impregnated paper	Without tap
X2	110 kV	pF	%	pF	%	Oil-impregnated paper	Without tap
X3	110 kV	pF	%	pF	%	Oil-impregnated paper	Without tap

Tap Changers nameplate data**DETC**

Serial number	
Manufacturer	ABB
Manufacturer type	Manual
Winding	H
Tap scheme	1...N
No. of taps	5

Tap	Voltage
1	76125.0 V
2	74310.0 V
3	72500.0 V

Tap	Voltage
4	70690.0 V
5	68875.0 V

Surge Arrester nameplate data

Surge arrester H1

Serial number	Manufacturer	Manufacturing year	Overall catalog no	Units in stack
001	CERAN	1994		1

Position	Serial No.	Voltage L-L	Voltage L-N	MCOV rating	Unit ID
1		kV	kV	kV	

Surge arrester H2

Serial number	Manufacturer	Manufacturing year	Overall catalog no	Units in stack
002	CERAN	1994		1

Position	Serial No.	Voltage L-L	Voltage L-N	MCOV rating	Unit ID
1		kV	kV	kV	

Surge arrester H3

Serial number	Manufacturer	Manufacturing year	Overall catalog no	Units in stack
003	CERAN	1994		1

Position	Serial No.	Voltage L-L	Voltage L-N	MCOV rating	Unit ID
1		kV	kV	kV	

Test set information

Model	Serial number	Calibration date
TESTRANO 600	LN612B	2024-07-08
CP TD12	LN574C	2024-07-27

Global test conditions

Weather	Partly cloudy	Humidity	93 %
Unit location	Outside	Ambient temperature	24 °C

Overall PF & CAP

Ambient temperature	24 °C	Weather	Partly cloudy
Top oil temperature	30 °C	Humidity	93 %

Comments

--

Standard test**Block 1: injection at H**

Corr. temperature	30 °C
Corr. factor	0.8

No.	Meas.	Test mode	Freq.	V out	I out	Watt losses	PF meas	PF corr	Cap. meas	Assessment
1	ICH+ICHL	GST	60.00 Hz	10.00 kV	51.44 mA	1827.70 mW	0.3553 %	0.2842 %	13643.7 pF	Pass
2	ICH	GSTg-A	60.00 Hz	10.00 kV	12.14 mA	624.79 mW	0.5148 %	0.4118 %	3216.9 pF	Pass
3	ICHL	UST-A	60.00 Hz	10.00 kV	39.31 mA	1189.87 mW	0.3027 %	0.2422 %	10426.7 pF	Pass

Block 2: injection at X

Corr. temperature	30 °C
Corr. factor	0.8

No.	Meas.	Test mode	Freq.	V out	I out	Watt losses	PF meas	PF corr	Cap. meas	Assessment
4	ICL+ICLH	GST	60.00 Hz	7.00 kV	58.64 mA	1480.91 mW	0.3608 %	0.2886 %	22218.4 pF	Pass
5	ICL	GSTg-A	60.00 Hz	7.00 kV	31.13 mA	932.68 mW	0.4280 %	0.3424 %	11794.4 pF	Pass
6	ICLH	UST-A	60.00 Hz	7.00 kV	27.52 mA	581.10 mW	0.3017 %	0.2414 %	10426.8 pF	Pass

Bushing H PF & CAP - C1

Ambient temperature	24 °C	Weather	Partly cloudy
Top oil temperature	30 °C	Humidity	93 %

Comments

--

Standard test

Corr. factor		1								
No.	Meas.	Test mode	Freq.	V out	I out	Watt losses	PF meas	PF corr	Cap. meas	Assessment
1	H1	UST-A	60.00 Hz	10.00 kV	0.99 mA	31.90 mW	0.3213 %	0.3213 %	263.4 pF	Pass
2	H2	UST-A	60.00 Hz	10.00 kV	0.99 mA	29.64 mW	0.2992 %	0.2992 %	262.8 pF	Pass
3	H3	UST-A	60.00 Hz	10.00 kV	0.99 mA	29.69 mW	0.2997 %	0.2997 %	262.8 pF	Pass
4	H0	UST-A	60.00 Hz	kV	mA	mW	%	%	pF	Not ass.

Bushing H PF & CAP - C2

Ambient temperature	24 °C	Weather	Partly cloudy
Top oil temperature	30 °C	Humidity	93 %

Comments

--

Standard test

No.	Meas.	Test mode	Freq.	V out	I out	Watt losses	PF meas	PF corr	Cap. meas	Assessment
1	H1	GSTg-A	60.00 Hz	0.50 kV	0.10 mA	0.70 mW	1.3979 %	1.3979 %	530.8 pF	Inv.
2	H2	GSTg-A	60.00 Hz	0.50 kV	0.10 mA	0.62 mW	1.1962 %	1.1962 %	542.6 pF	Inv.
3	H3	GSTg-A	60.00 Hz	0.50 kV	0.10 mA	0.72 mW	1.3787 %	1.3787 %	546.7 pF	Inv.
4	H0	GSTg-A	60.00 Hz	kV	mA	mW	%	%	pF	Not ass.

Bushing H – Energized Collar

Ambient temperature	24 °C	Weather	Partly cloudy
Top oil temperature	30 °C	Humidity	93 %

Comments

--

Standard test

No.	Meas.	Test mode	Freq.	V out	I out	Watt losses	Assessment
1	H1	UST-A	60.00 Hz	12.00 kV	0.09 mA	130.75 mW	Pass
2	H2	UST-A	60.00 Hz	12.00 kV	0.10 mA	189.88 mW	Pass
3	H3	UST-A	60.00 Hz	12.00 kV	0.09 mA	111.40 mW	Pass
4	H0	UST-A	60.00 Hz	12.00 kV	0.06 mA	107.81 mW	Pass

Test set information

Model	Serial number	Calibration date
TESTRANO 600	LN612B	2024-07-08
CP TD12	LN574C	2024-07-27

Exciting Current

Comment

Measurement settings

Test voltage	5 kV
Test frequency	60.00 Hz
Tap changer under test	DETC

Averaging	2
Bandwidth	±20 Hz
AvoidTestFrequency	No

Use reference voltage	No
-----------------------	----

Measurements (sorted by tap)

Tap	Phase	V out	I out	I phase	Watt losses	Reactance	Assessment
4	A	5.00 kV	86.237 mA	-59.73 °	217.403 W	50.075 kΩ	Pass
4	B	5.00 kV	69.623 mA	-60.27 °	172.660 W	62.365 kΩ	Pass
4	C	5.00 kV	87.474 mA	-60.02 °	218.551 W	49.513 kΩ	Pass

Exciting current

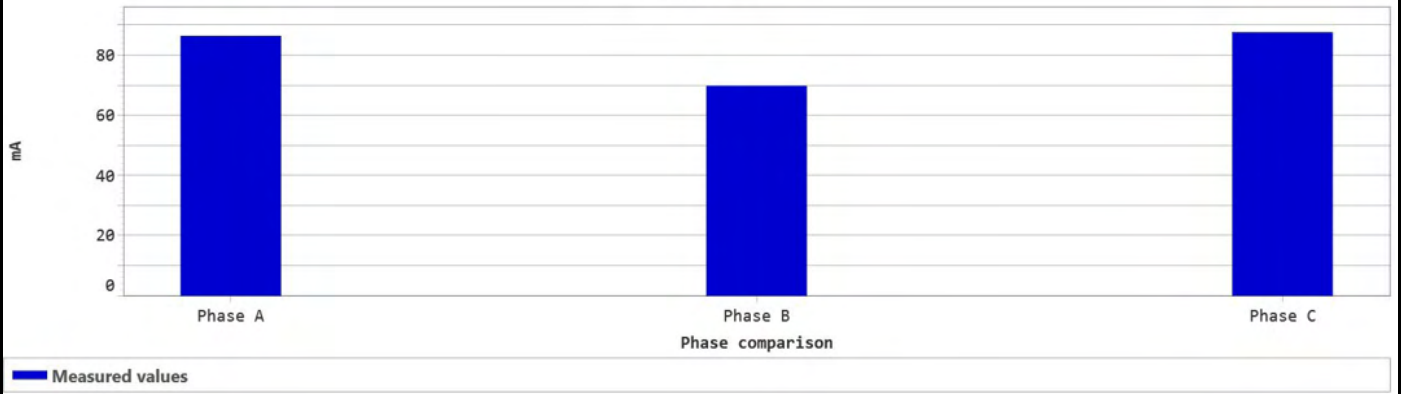

Watt losses

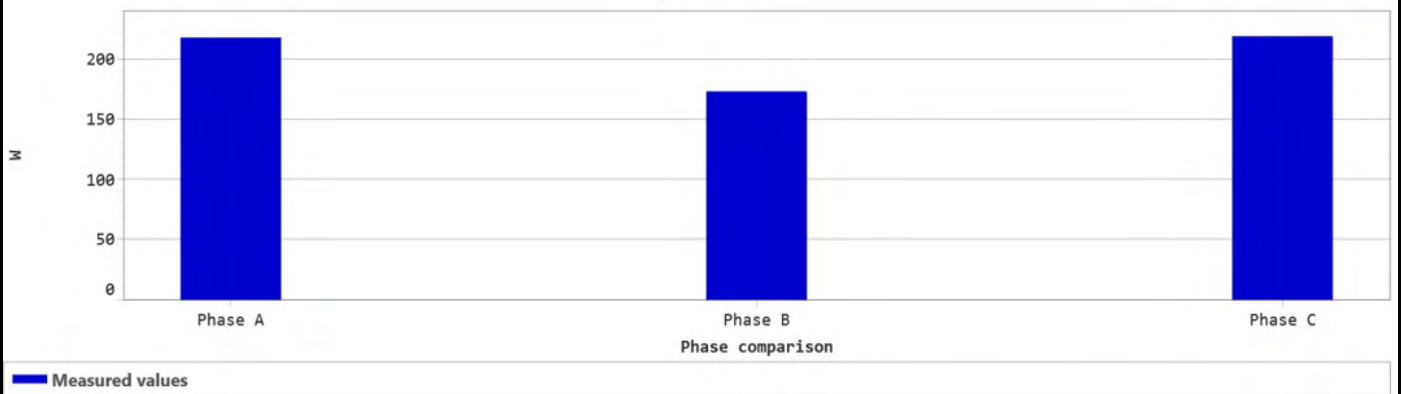

Surge Arrester Watt Losses H

Ambient temperature	24 °C	Weather	Partly cloudy
Top oil temperature	30 °C	Humidity	93 %

Comments

Standard test

Meas.	Position	Test mode	Freq.	V out	I out	Watt losses	Assessment
H1	1	GST	60.00 Hz	1.00 kV	0.03 mA	1.43 mW	Pass
H2	1	GST	60.00 Hz	1.00 kV	0.03 mA	1.52 mW	Pass
H3	1	GST	60.00 Hz	1.00 kV	0.03 mA	1.47 mW	Pass

Test set information

Model	Serial number	Calibration date
TESTRANO 600	LN612B	2024-07-08
CP TD12	LN574C	2024-07-27

TTR H-X

Comment

--

Measurement settings

Test voltage	120 V
Test frequency	60.00 Hz
Tap changer under test	DETC

Ratio	TTR*
-------	------

Measurements (sorted by tap)

Tap	Phase	Nom. Ratio	$V_{prim} (L-L)$	I_{prim}	$V_{sec} (L-L)$	V_{phase}	TTR*	Ratio dev	Assessment
4	A	2.9575	119.88 V	2.100 mA	23.46 V	30.04 °	2.9505	-0.24 %	Pass
4	B	2.9575	119.85 V	2.139 mA	23.46 V	29.95 °	2.9497	-0.26 %	Pass
4	C	2.9575	119.70 V	1.469 mA	23.46 V	30.01 °	2.9461	-0.38 %	Pass

Graphs for standard test

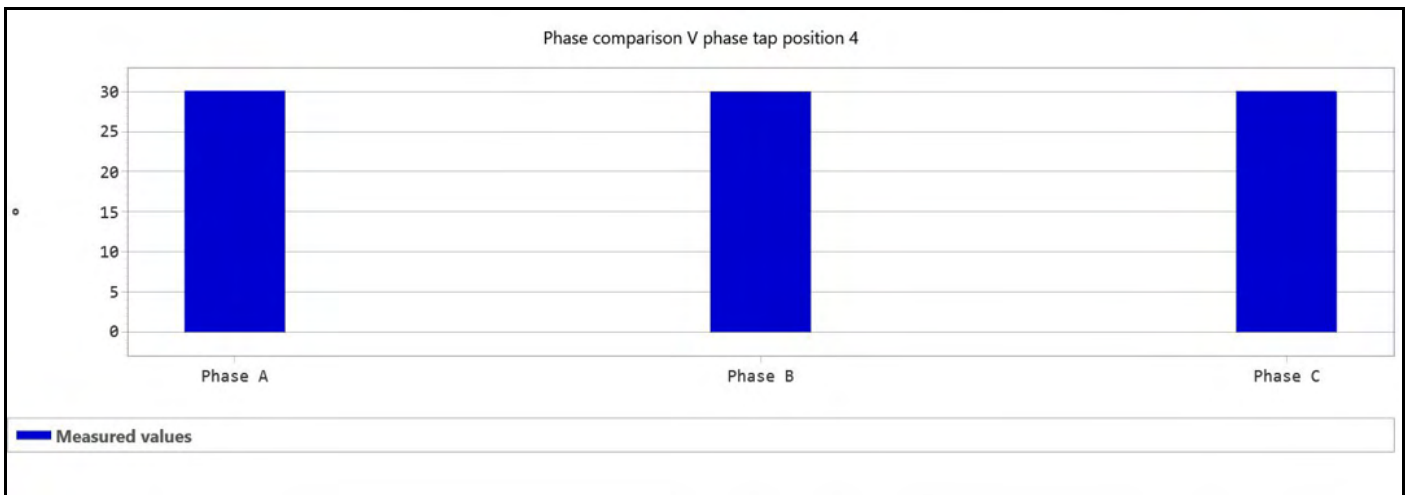
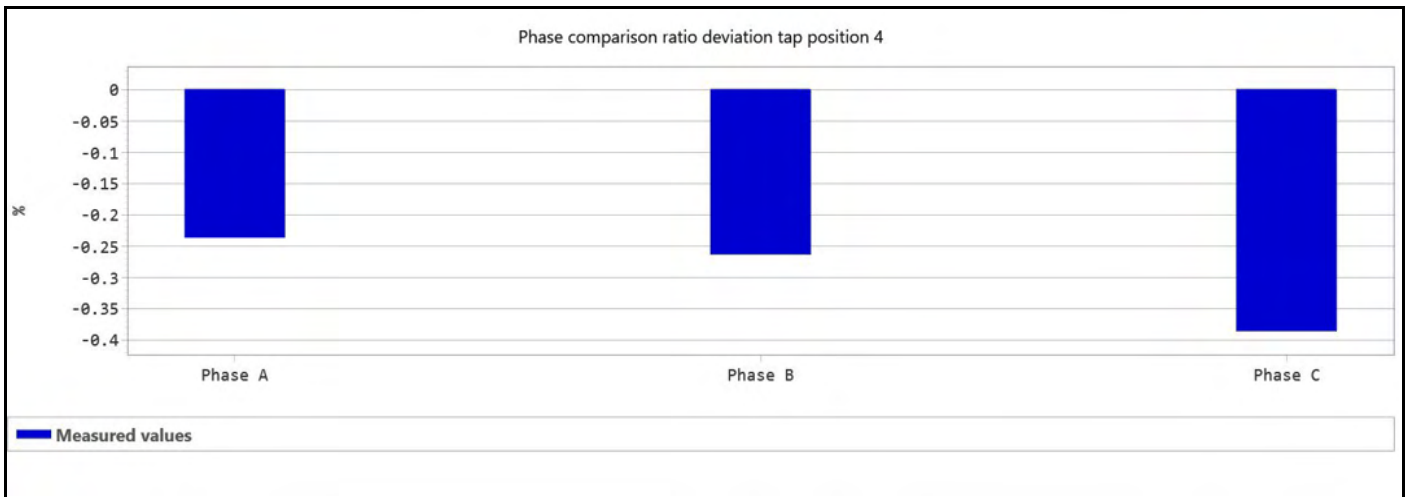
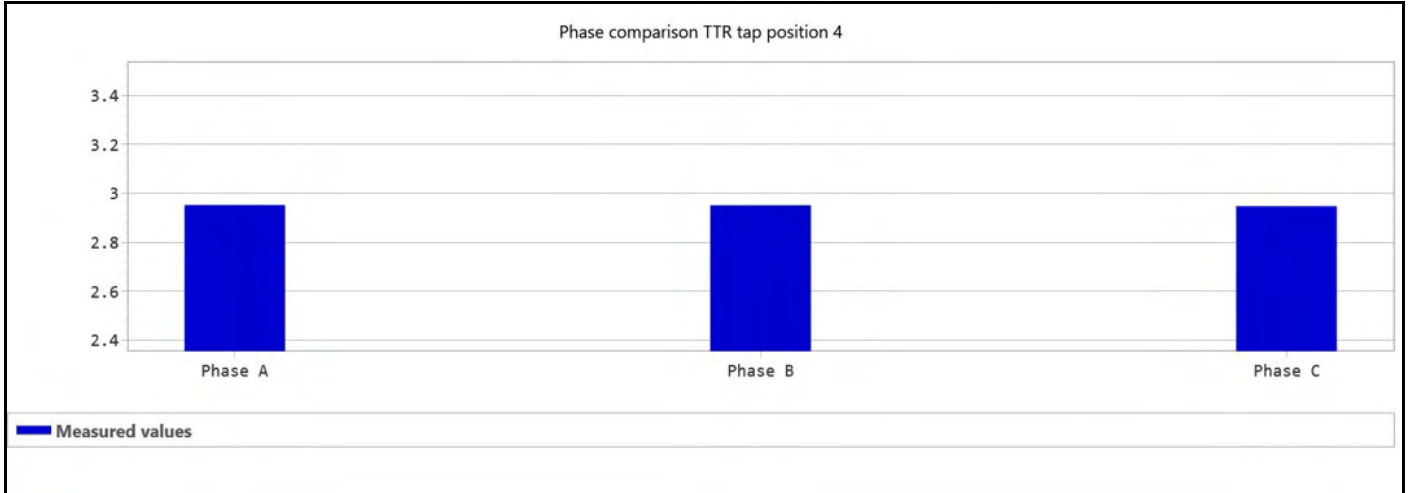

Graph for exciting current

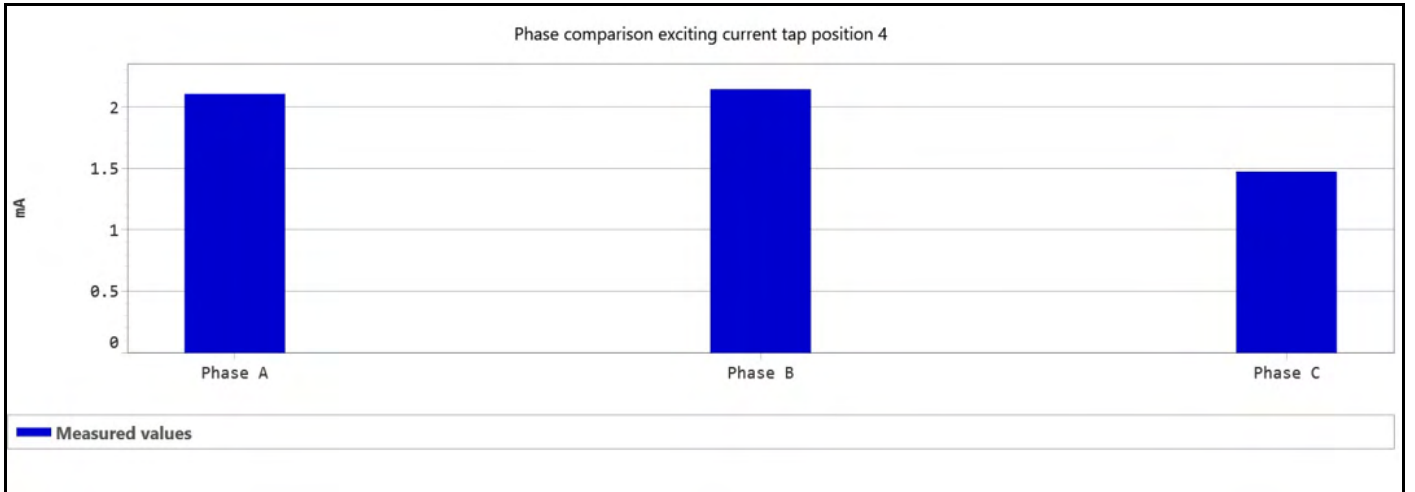

Test set information

Model	Serial number	Calibration date
TESTRANO 600	LN612B	2024-07-08
CP TD12	LN574C	2024-07-27

DC Winding Resistance H

Comment

--

Measurement settings

Test current	5 A	Tap changer under test	DETC
Output mode	16 A @ 113 V		
	3 ph.		
Measurement	L-N		

Automatic result	True
Settling time (At)	5 s
Tolerance R dev	0.1 %
Recording time	200.0 ms

Tap	A (H1 - H0)			B (H2 - H0)			C (H3 - H0)		
	<i>R meas</i>	<i>R dev</i>	<i>R corr</i>	<i>R meas</i>	<i>R dev</i>	<i>R corr</i>	<i>R meas</i>	<i>R dev</i>	<i>R corr</i>
4	105.662 mΩ	0.067 %	105.662 mΩ	105.519 mΩ	0.008 %	105.519 mΩ	106.042 mΩ	0.033 %	106.042 mΩ

Graphs for standard test

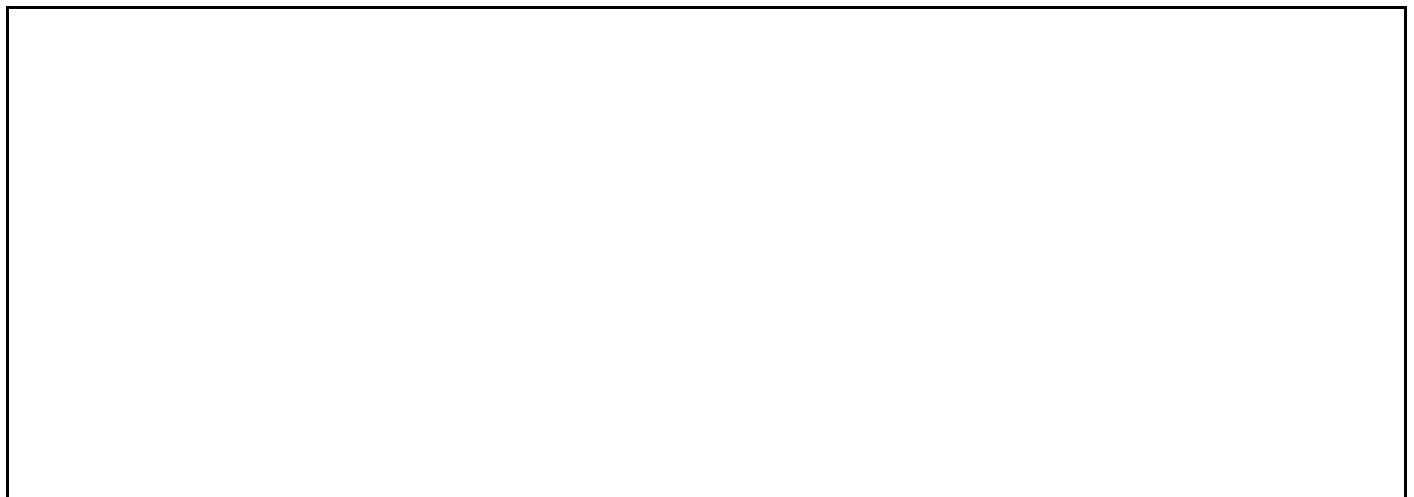
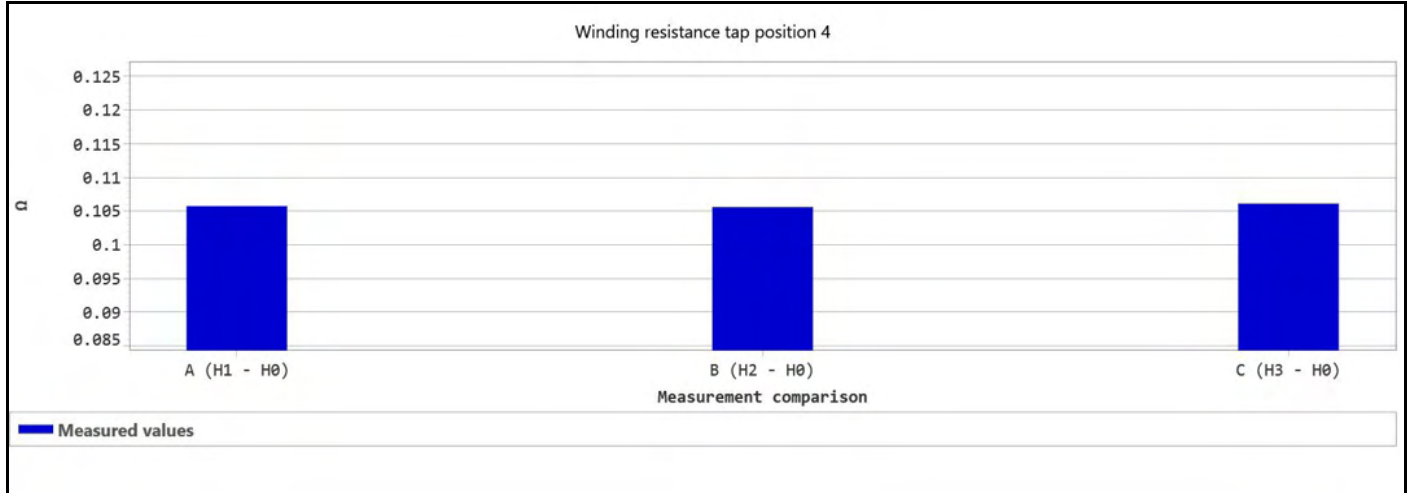

Test set information

Model	Serial number	Calibration date
TESTRANO 600	LN612B	2024-07-08
CP TD12	LN574C	2024-07-27

DC Winding Resistance X

Comment

--

Measurement settings

Test current	10 A
Output mode	33 A @ 170 V
	1 ph.

Automatic result	True
Settling time (At)	5 s
Tolerance R dev	0.1 %
Recording time	200.0 ms

A (X1 - X2)			B (X2 - X3)			C (X3 - X1)		
<i>R meas</i>	<i>R dev</i>	<i>R corr</i>	<i>R meas</i>	<i>R dev</i>	<i>R corr</i>	<i>R meas</i>	<i>R dev</i>	<i>R corr</i>
10.245 mΩ	0.062 %	10.245 mΩ	6.947 mΩ	0.071 %	6.947 mΩ	10.093 mΩ	0.058 %	10.093 mΩ

Graphs for standard test

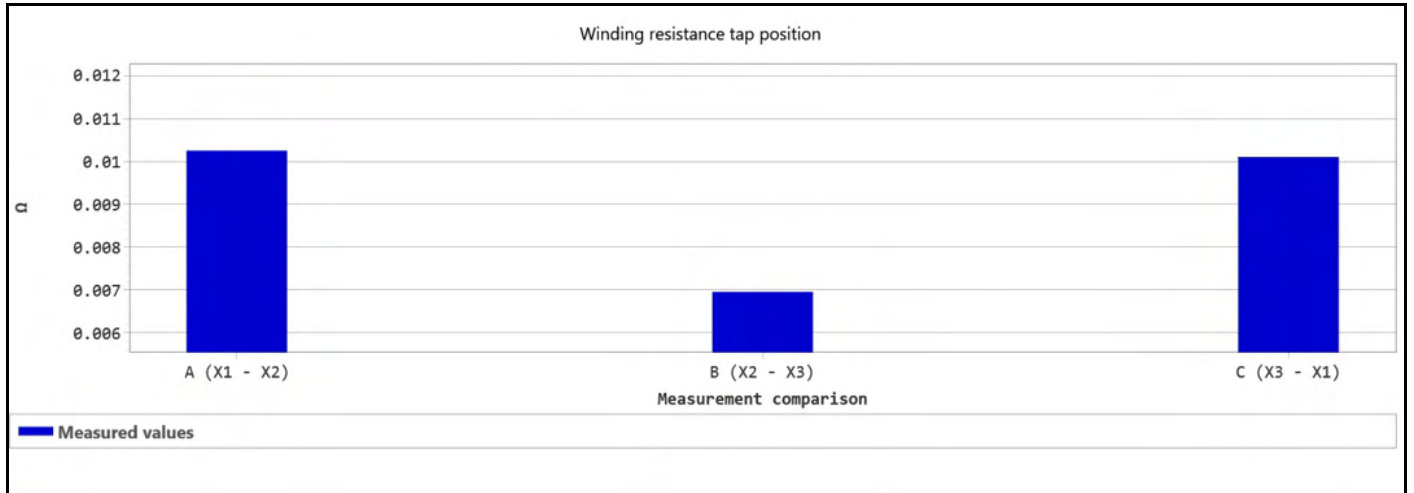

TESTING REPORTS FOR T1-AUX

624942 - Aux 1



Client	624946 - T1- Aux		
Execution date	10/1/2024	Reason of the job	Routine
Tested by	Falchetti, Matthew	Location	Orange Cogen
Approved by		Asset	Transformer
Report ID	2	Asset type	Two-winding
Report issue date	10/9/2024 12:19:30 PM	Asset serial number	ZAV9721-0101
Work order		Manufacturer	ABB

Summary				
Megger - Tests				
	30 sec.	1 min.	10 min.	
High to Low -	19.73 G	25.3 G	43.3 G	
High to Ground -	21.9 G			
Low to Ground -	13.27 G			

Performed tests	Assessment
Overall PF & CAP	Pass
Exciting Current	Pass
Surge Arrester Watt Losses H	Pass
TTR H-X	Pass
DC Winding Resistance H	Pass
DC Winding Resistance X	Pass

Overall Assessment	No Faults - Passed
--------------------	--------------------

Tested by:
Matthew Falchetti / Andrew Kirk

Approved by:
Matthew Falchetti

Location & company information			
Location		Company	
Name	Orange Cogen	Company	TRC Companies
Region		Department	
Division	TRC Companies	Address	
Area		City	Lakeland
Plant	Orange Cogen	State/Province	Florida
Address	1901 S. Clear Springs Rd	Postal code	
City	Bartow	Country	United States
State/Province	Florida	Phone No.	
Postal code	33830	Fax No.	
Country	United States	E-mail	

Geo coordinates	
-----------------	--

Contact person	
Name	Lee Bland
Phone No. 1	
Phone No. 2	
Fax No.	
E-mail	

Comment

Transformer nameplate data			
Serial number	ZAV9721-0101	Apparatus ID	T1-Aux
Manufacturer	ABB	Feeder	
Manufacturing year	1994	No. phases	3
Manufacturer type	RSL	Vector group	Dyn1

Comment

Voltage ratings			
Winding	Voltage L-L	Voltage L-N	Insul. level L-L
H	13.500 kV	kV	95 kV
X	4.160 kV	2.402 kV	60 kV

Power ratings		
Rated power	Cooling class	Temp. rise wind.
6.000 MVA	OA	

Current ratings at rated power		
Winding		
H	X	Rated power
A	A	6.000 MVA

Short-circuit rating		
Max. short-circuit current	kA	s

Impedances	
Ref. temp.	75 °C

Leakage reactance H - X					
Zk[%]	Base power	Base voltage	Load losses Pk	OLTC position	DETC position
6.010 %	MVA	kV	W		4

Zero sequence impedance	
Base power	6.00 MVA
Base voltage	13.800 kV
Description	Z0[%]
Secondary	%

Others	
Category	Distribution
Status	In operation
Tank type	Nitrogen blanketed
Insulation medium	Mineral oil
Fluid insulation volume	1347 gals
Fluid insulation weight	lbs
Total weight	32508 lbs

Bushings nameplate data							
Pos.	Serial No.	Manufact.	Manufacturer type	Man. year	Voltage L-ground	Max. system voltage	Rated current
H1		ABB		1994	13.8 kV	15.0 kV	A
H2		ABB		1994	13.8 kV	15.0 kV	A
H3		ABB		1994	13.8 kV	15.0 kV	A
X1		ABB		1994	4.2 kV	4.2 kV	A
X2		ABB		1994	4.2 kV	4.2 kV	A
X3		ABB		1994	4.2 kV	4.2 kV	A
X0		ABB		1994	4.2 kV	4.2 kV	A

Pos.	Insul. level LL	Cap. (C1)	PF (C1)	Cap. (C2)	PF (C2)	Insulation type	Tap type
H1	V	pF	%	pF	%	Porcelain dry type	Without tap
H2	V	pF	%	pF	%	Porcelain dry type	Without tap
H3	V	pF	%	pF	%	Porcelain dry type	Without tap
X1	V	pF	%	pF	%	Porcelain dry type	Without tap
X2	V	pF	%	pF	%	Porcelain dry type	Without tap
X3	V	pF	%	pF	%	Porcelain dry type	Without tap
X0	V	pF	%	pF	%	Porcelain dry type	Without tap

Tap Changers nameplate data

DETC	
Serial number	
Manufacturer	ABB
Manufacturer type	Manual
Winding	H
Tap scheme	1...N
No. of taps	5

Tap	Voltage
1	14400.0 V
2	14100.0 V
3	13800.0 V

Tap	Voltage
4	13500.0 V
5	13200.0 V

Surge Arrester nameplate data

Surge arrester H1

Serial number	Manufacturer	Manufacturing year	Overall catalog no	Units in stock
94E5153	ABB	1994	EXLIM Q	1

Position	Serial No.	Voltage L-L	Voltage L-N	MCOV rating	Unit ID
1	94E5153	kV	kV	15.30 kV	

Surge arrester H2

Serial number	Manufacturer	Manufacturing year	Overall catalog no	Units in stock
94E5150	ABB	1994	EXLIM Q	1

Position	Serial No.	Voltage L-L	Voltage L-N	MCOV rating	Unit ID
1		kV	kV	15.30 kV	

Surge arrester H3

Serial number	Manufacturer	Manufacturing year	Overall catalog no	Units in stock
94E5155	ABB	1994	EXLIM Q	1

Position	Serial No.	Voltage L-L	Voltage L-N	MCOV rating	Unit ID
1		kV	kV	15.30 kV	

Test set information

Model	Serial number	Calibration date
TESTRANO 600	LN612B	2024-07-08
CP TD12	LN574C	2024-07-27

Global test conditions

Weather	Partly cloudy	Humidity	79 %
Unit location	Outside	Ambient temperature	29 °C

Overall PF & CAP

Ambient temperature	29 °C	Weather	Partly cloudy
Top oil temperature	40 °C	Humidity	79 %

Comments

--

Standard test**Block 1: injection at H**

Corr. temperature	40 °C
Corr. factor	0.64

No.	Meas.	Test mode	Freq.	V out	I out	Watt losses	PF meas	PF corr	Cap. meas	Assessment
1	ICH+ICHL	GST	60.00 Hz	7.00 kV	35.79 mA	1038.41 mW	0.4145 %	0.2653 %	13559.7 pF	Pass
2	ICH	GSTg-A	60.00 Hz	7.00 kV	8.69 mA	396.52 mW	0.6520 %	0.4173 %	3289.5 pF	Pass
3	ICHL	UST-A	60.00 Hz	7.00 kV	27.10 mA	628.04 mW	0.3311 %	0.2119 %	10270.2 pF	Pass

Block 2: injection at X

Corr. temperature	40 °C
Corr. factor	0.64

No.	Meas.	Test mode	Freq.	V out	I out	Watt losses	PF meas	PF corr	Cap. meas	Assessment
4	ICL+ICLH	GST	60.00 Hz	2.00 kV	13.84 mA	101.84 mW	0.3679 %	0.2354 %	18356.7 pF	Pass
5	ICL	GSTg-A	60.00 Hz	2.00 kV	6.10 mA	50.51 mW	0.4141 %	0.2650 %	8085.5 pF	Pass
6	ICLH	UST-A	60.00 Hz	2.00 kV	7.74 mA	51.08 mW	0.3299 %	0.2111 %	10270.1 pF	Pass

Test set information

Model	Serial number	Calibration date
TESTRANO 600	LN612B	2024-07-08
CP TD12	LN574C	2024-07-27

Exciting Current

Comment

--

Measurement settings

Test voltage	5 kV
Test frequency	60.00 Hz
Tap changer under test	DETC

Averaging	2
Bandwidth	±20 Hz
AvoidTestFrequency	No

Use reference voltage	No
-----------------------	----

Measurements (sorted by tap)

Tap	Phase	V out	I out	I phase	Watt losses	Reactance	Assessment
4	A	5.00 kV	114.155 mA	-25.98 °	513.153 W	19.185 kΩ	Pass
4	B	5.00 kV	86.737 mA	-26.15 °	389.333 W	25.405 kΩ	Pass
4	C	5.00 kV	113.721 mA	-26.20 °	510.234 W	19.415 kΩ	Pass

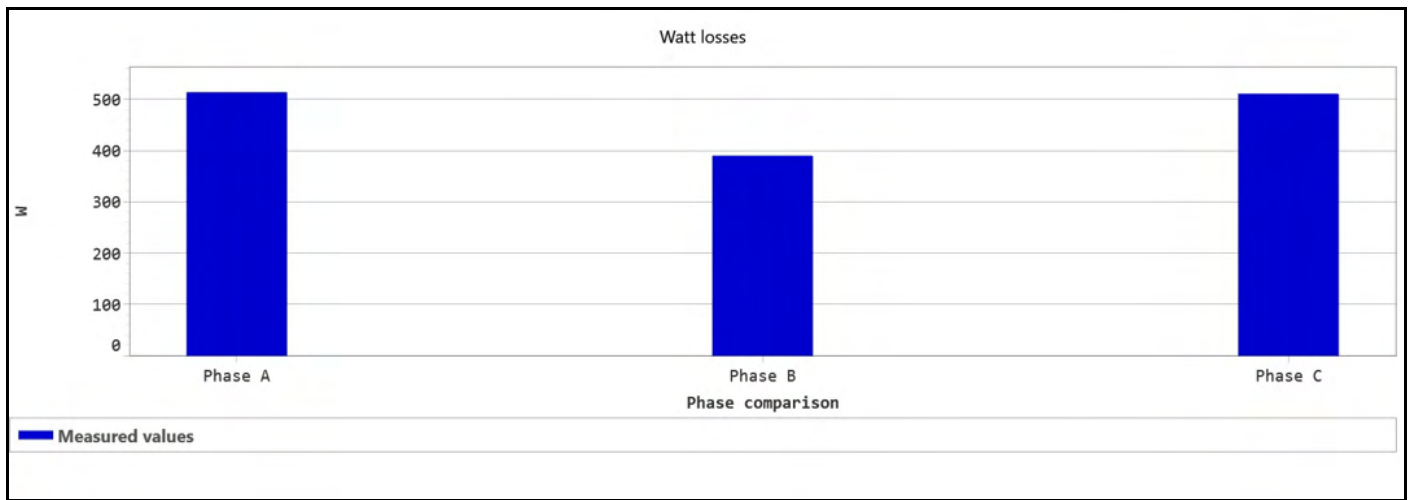
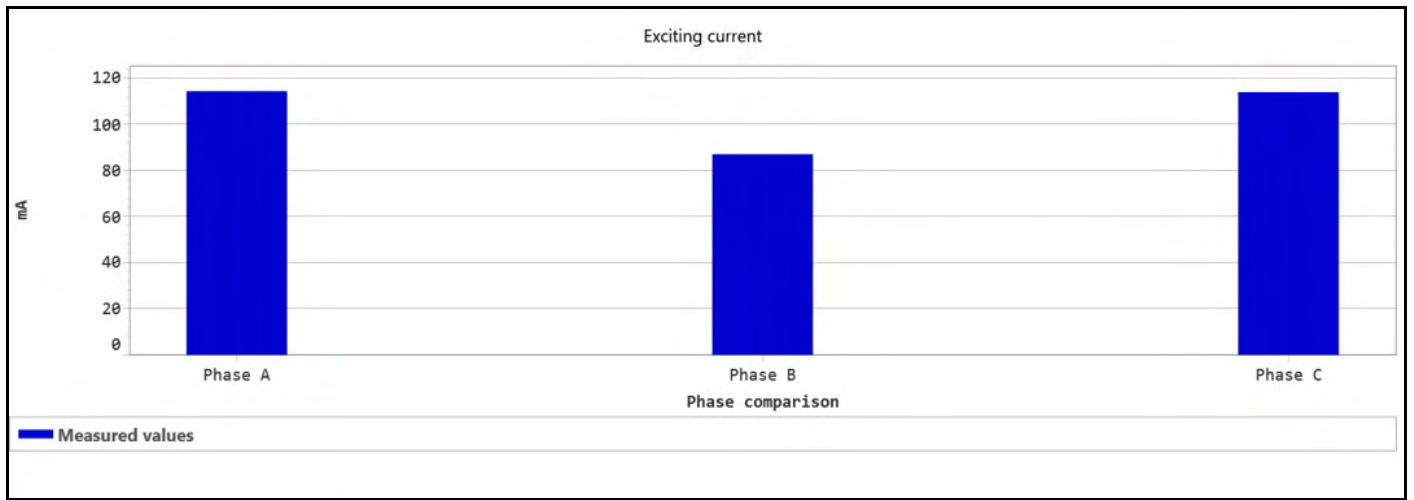

Surge Arrester Watt Losses H

Ambient temperature	29 °C	Weather	Partly cloudy
Top oil temperature	40 °C	Humidity	79 %

Comments

Standard test

Meas.	Position	Test mode	Freq.	V out	I out	Watt losses	Assessment
H1	1	GST	60.00 Hz	1.00 kV	0.06 mA	3.72 mW	Pass
H2	1	GST	60.00 Hz	1.00 kV	0.06 mA	3.63 mW	Pass
H3	1	GST	60.00 Hz	1.00 kV	0.06 mA	3.93 mW	Pass

Test set information

Model	Serial number	Calibration date
TESTRANO 600	LN612B	2024-07-08
CP TD12	LN574C	2024-07-27

TTR H-X

Comment

--

Measurement settings

Test voltage	120 V
Test frequency	60.00 Hz
Tap changer under test	DETC

Ratio	TTR*
-------	------

Measurements (sorted by tap)

Tap	Phase	Nom. Ratio	$V_{prim} (L-L)$	I_{prim}	$V_{sec} (L-L)$	V_{phase}	TTR*	Ratio dev	Assessment
4	A	5.6208	119.87 V	12.331 mA	36.92 V	30.01 °	5.6241	0.06 %	Pass
4	B	5.6208	119.88 V	8.881 mA	36.92 V	30 °	5.6242	0.06 %	Pass
4	C	5.6208	119.87 V	9.123 mA	36.92 V	30.01 °	5.6238	0.05 %	Pass

Graphs for standard test

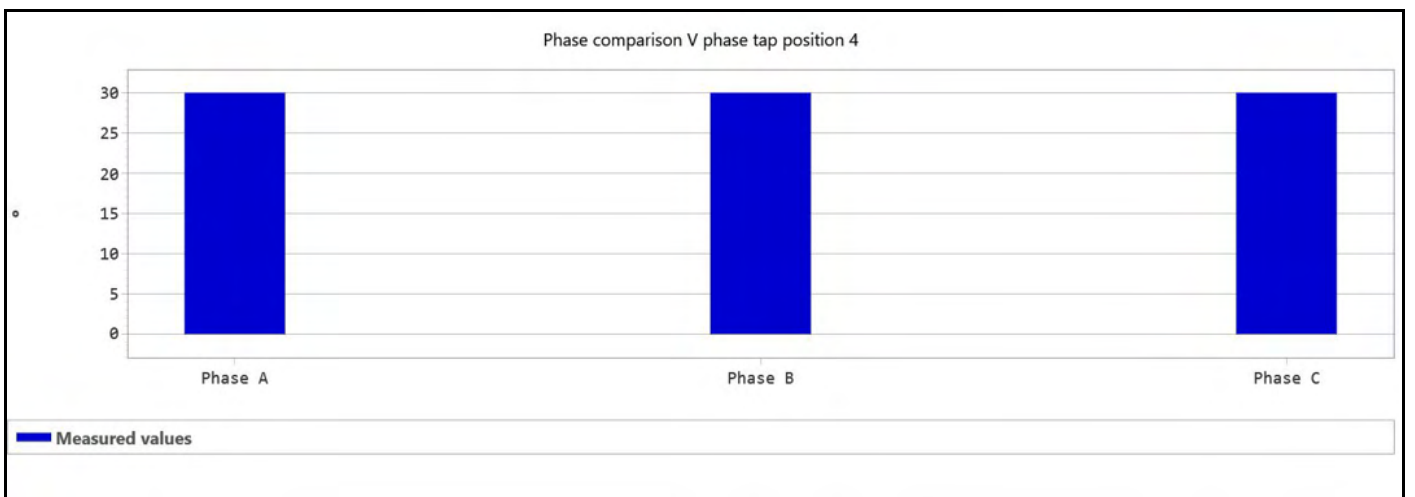
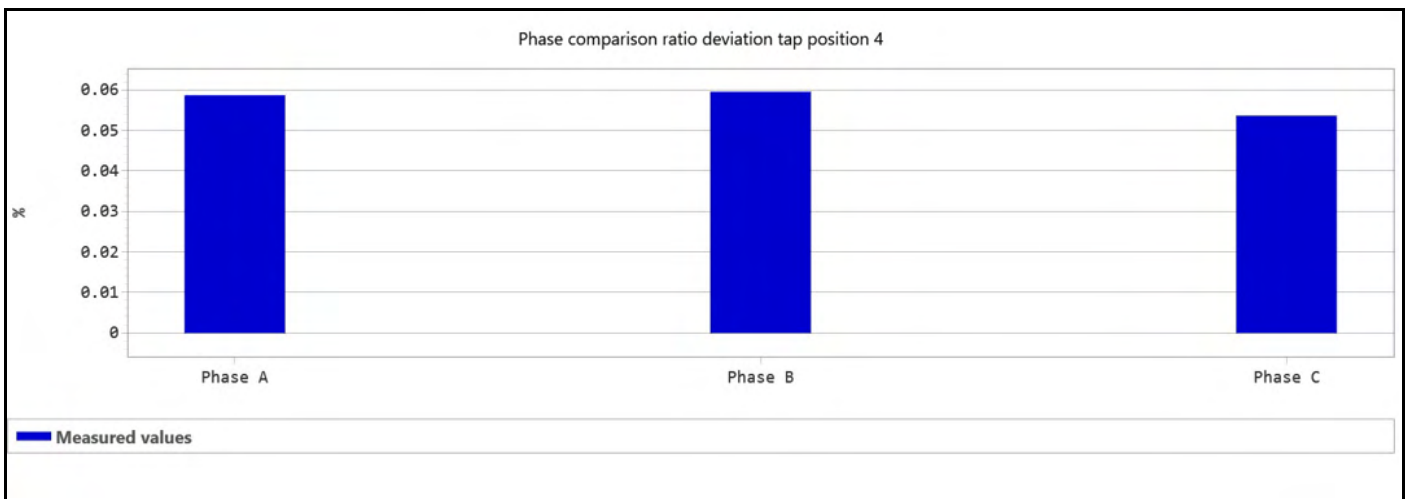
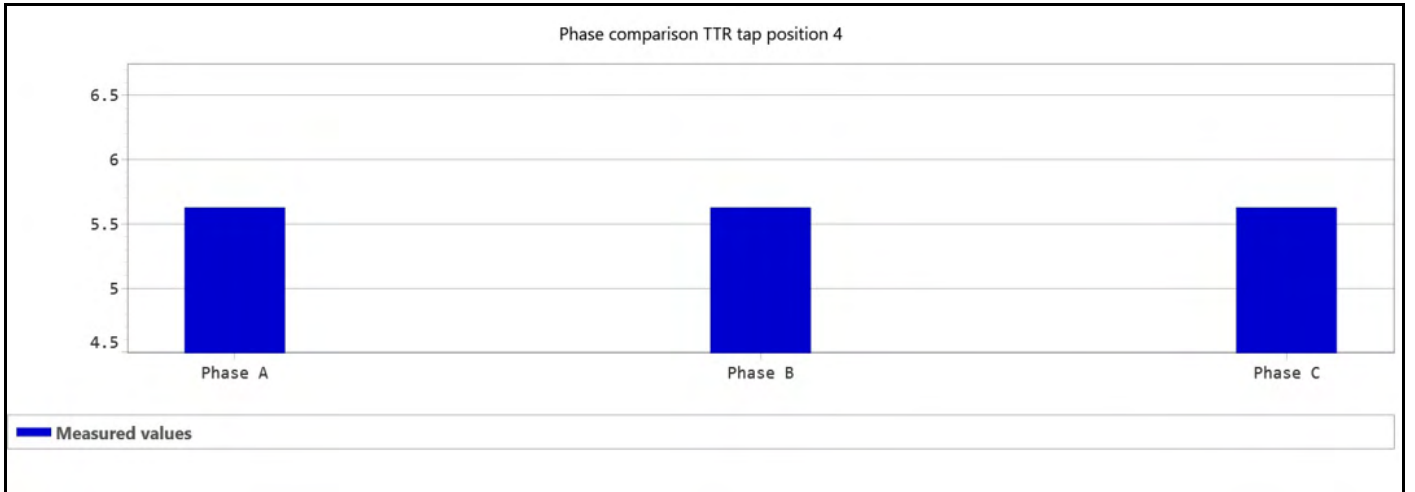

Graph for exciting current

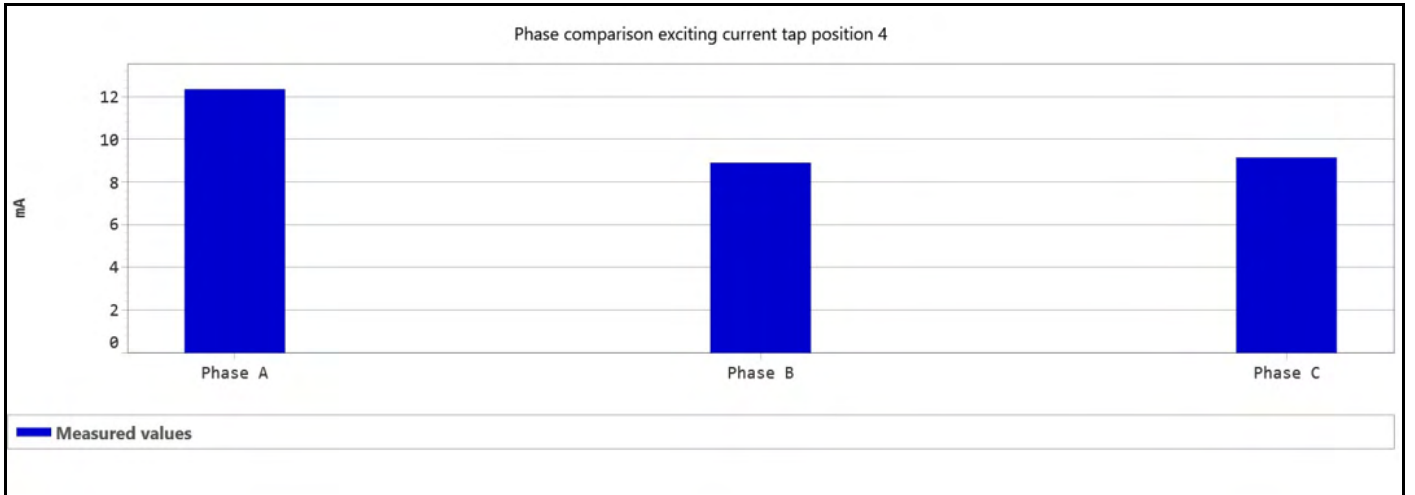

Test set information

Model	Serial number	Calibration date
TESTRANO 600	LN612B	2024-07-08
CP TD12	LN574C	2024-07-27

DC Winding Resistance H

Comment

--

Measurement settings

Test current	5 A	Tap changer under test	DETC
Output mode	16 A @ 340 V		
	1 ph.		

Automatic result	True
Settling time (At)	5 s
Tolerance R dev	0.1 %
Recording time	200.0 ms

	A (H1 - H3)			B (H2 - H1)			C (H3 - H2)		
Tap	<i>R meas</i>	<i>R dev</i>	<i>R corr</i>	<i>R meas</i>	<i>R dev</i>	<i>R corr</i>	<i>R meas</i>	<i>R dev</i>	<i>R corr</i>
4	158.025 mΩ	0.033 %	158.025 mΩ	162.377 mΩ	0.038 %	162.377 mΩ	162.138 mΩ	0.016 %	162.138 mΩ

Graphs for standard test

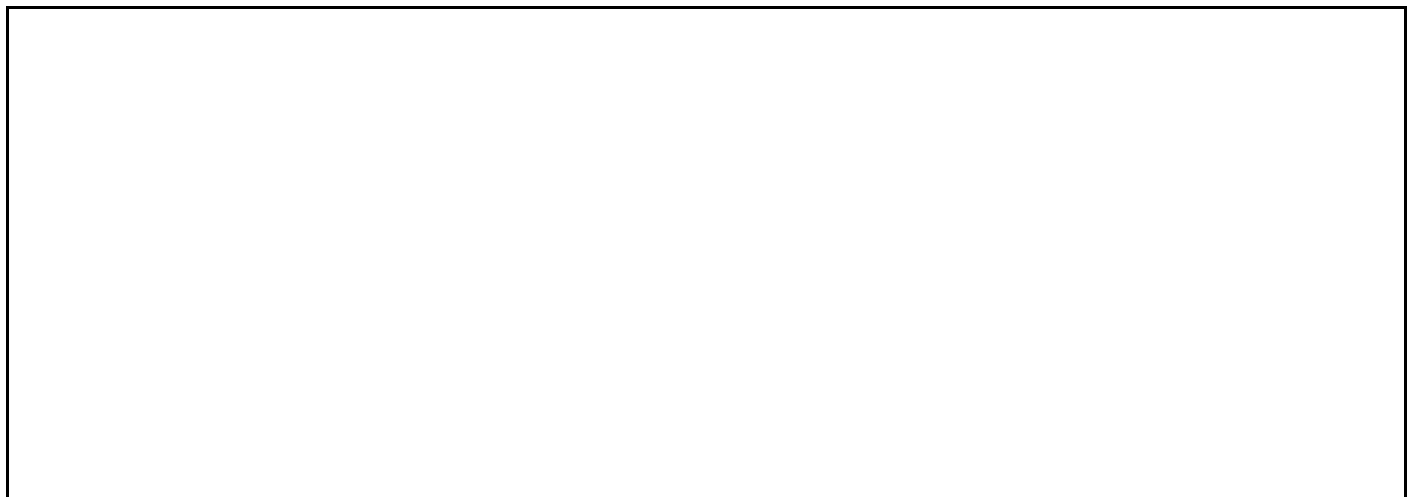
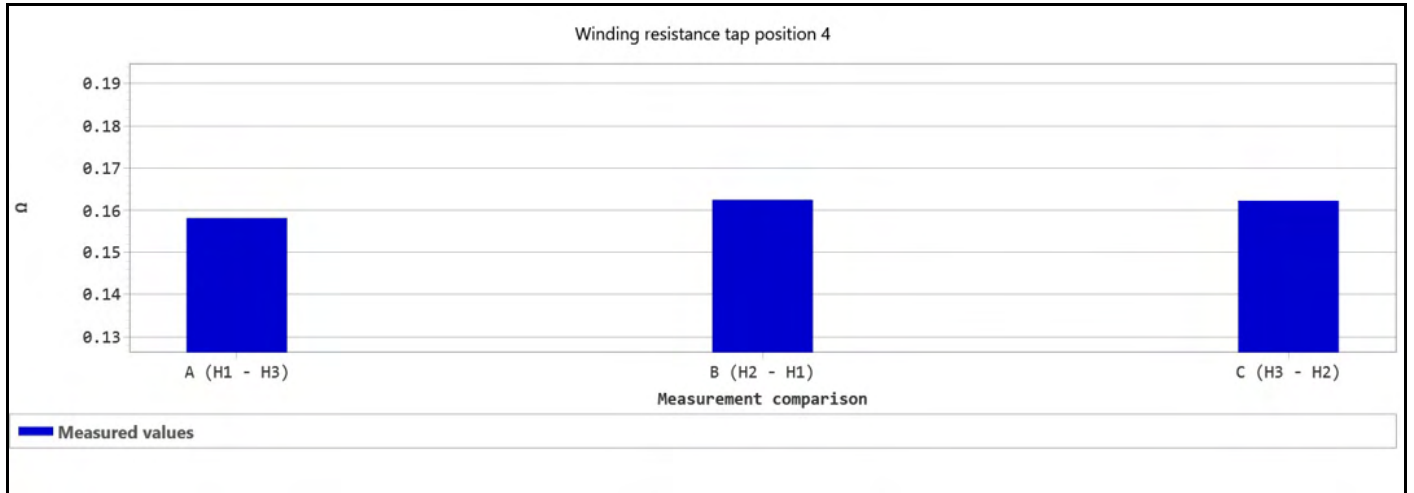

Test set information

Model	Serial number	Calibration date
TESTRANO 600	LN612B	2024-07-08
CP TD12	LN574C	2024-07-27

DC Winding Resistance X

Comment

--

Measurement settings

Test current	10 A
Output mode	33 A @ 56 V
	3 ph.
Measurement	L-N

Automatic result	True
Settling time (At)	5 s
Tolerance R dev	0.01 %
Recording time	200.0 ms

A (X1 - X0)			B (X2 - X0)			C (X3 - X0)		
<i>R meas</i>	<i>R dev</i>	<i>R corr</i>	<i>R meas</i>	<i>R dev</i>	<i>R corr</i>	<i>R meas</i>	<i>R dev</i>	<i>R corr</i>
6.221 mΩ	0.005 %	6.221 mΩ	6.108 mΩ	0.001 %	6.108 mΩ	6.061 mΩ	0.007 %	6.061 mΩ

Graphs for standard test

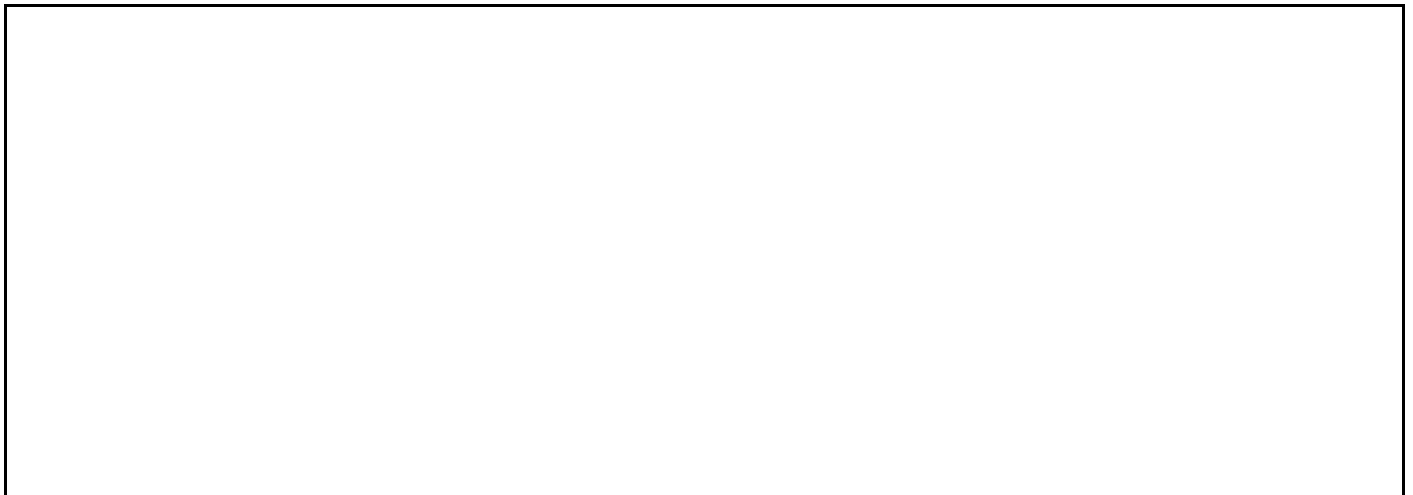
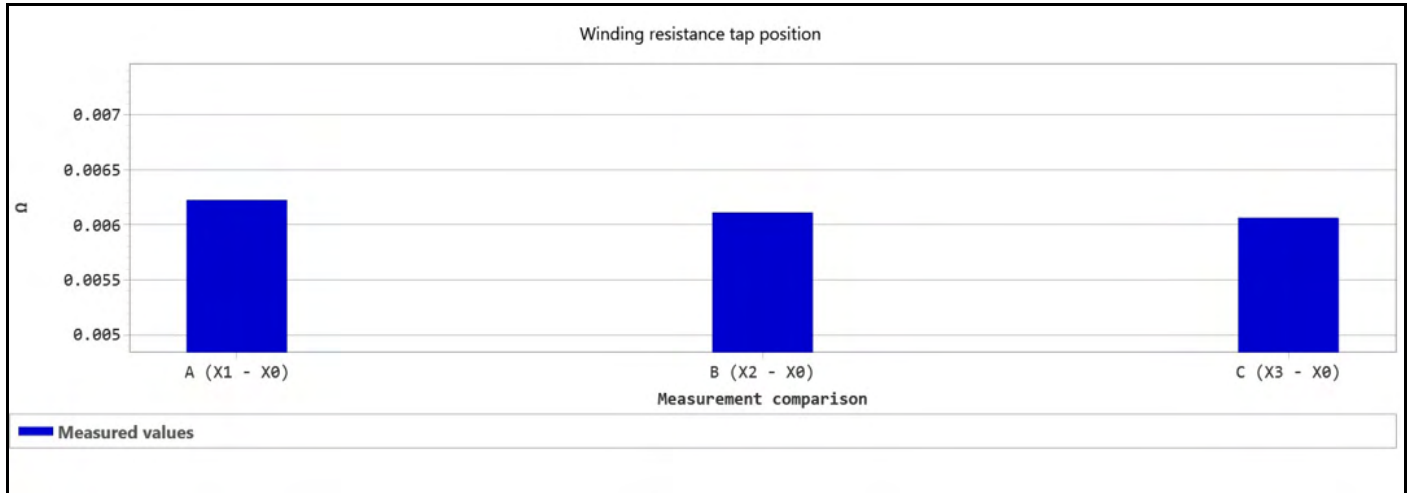

TESTING REPORTS FOR 1B DRY TYPE

624946 - 1B - DRY TYPE



Client		624946 - 1B - Dry type	
Execution date	10/4/2024	Reason of the job	Routine
Tested by	Matthew Falchetti	Location	Orange Cogen
Approved by		Asset	Transformer
Report ID	2	Asset type	Two-winding
Report issue date	10/9/2024 12:23:27 PM	Asset serial number	24-34785-01 1B
Work order		Manufacturer	ABB

Summary
Megger Test High to Ground - 69.2 Megaohms Low to Ground - 20.2 Megaohms

Performed tests	Assessment
Overall PF & CAP	Pass
TTR H-X	Pass
DC Winding Resistance H	Pass
DC Winding Resistance X	Pass

Overall Assessment	No Faults - Passed
--------------------	--------------------

Tested by:
Matthew Falchetti / Andrew Kirk

Approved by:
Matthew Falchetti

Location & company information			
Location		Company	
Name	Orange Cogen	Company	TRC Companies
Region		Department	
Division	TRC Companies	Address	
Area		City	Lakeland
Plant	Orange Cogen	State/Province	Florida
Address	1901 S. Clear Springs Rd	Postal code	
City	Bartow	Country	United States
State/Province	Florida	Phone No.	
Postal code	33830	Fax No.	
Country	United States	E-mail	

Geo coordinates	
-----------------	--

Contact person	
Name	
Phone No. 1	
Phone No. 2	
Fax No.	
E-mail	

Comment

Transformer nameplate data			
Serial number	24-34785-01 1B	Apparatus ID	Station Service Transformer 1B
Manufacturer	ABB	Feeder	
Manufacturing year	1994	No. phases	3
Manufacturer type	Vent	Vector group	Dyn1

Comment

Voltage ratings			
Winding	Voltage L-L	Voltage L-N	Insul. level L-L
H	4.056 kV	kV	60 kV
X	0.480 kV	0.277 kV	10 kV

Power ratings		
Rated power	Cooling class	Temp. rise wind.
2.500 MVA	OA	

Current ratings at rated power		
Winding		
H	X	Rated power
356.000 A	3007.000 A	2.500 MVA

Short-circuit rating		
Max. short-circuit current	kA	s

Impedances	
Ref. temp.	75 °C

Leakage reactance H - X

Zk[%]	Base power	Base voltage	Load losses Pk	OLTC position	DETC position
%	MVA	kV	W		4

Zero sequence impedance

Base power	2.50 MVA
Base voltage	4.160 kV
Description	Z0[%]
Secondary	5.85 %

Others

Category	Distribution
Status	In operation
Tank type	Other
Insulation medium	Dry type
Fluid insulation volume	gals
Fluid insulation weight	lbs
Total weight	17900 lbs

Bushings nameplate data

Pos.	Serial No.	Manufact.	Manufacturer type	Man. year	Voltage L-ground	Max. system voltage	Rated current
H1					4.2 kV	4.2 kV	A
H2					4.2 kV	4.2 kV	A
H3					4.2 kV	4.2 kV	A
X1					0.5 kV	0.5 kV	A
X2					0.5 kV	0.5 kV	A
X3					0.5 kV	0.5 kV	A
X0					0.5 kV	0.5 kV	A

Pos.	Insul. level LL	Cap. (C1)	PF (C1)	Cap. (C2)	PF (C2)	Insulation type	Tap type
H1	V	pF	%	pF	%	Other	Without tap
H2	V	pF	%	pF	%	Other	Without tap
H3	V	pF	%	pF	%	Other	Without tap
X1	V	pF	%	pF	%	Other	Without tap
X2	V	pF	%	pF	%	Other	Without tap
X3	V	pF	%	pF	%	Other	Without tap
X0	V	pF	%	pF	%	Other	Without tap

Tap Changers nameplate data**DETC**

Serial number	
Manufacturer	ABB
Manufacturer type	Manual
Winding	H
Tap scheme	1...N
No. of taps	5

Tap	Voltage
1	4638.0 V
2	4264.0 V
3	4160.0 V

Tap	Voltage
4	4056.0 V
5	3952.0 V

Test set information

Model	Serial number	Calibration date
TESTRANO 600	LN612B	2024-07-08
CP TD12	LN574C	2024-07-27

Global test conditions

Weather	Clear	Humidity	89 %
Unit location	Outside	Ambient temperature	27 °C

Overall PF & CAP			
Ambient temperature	27 °C	Weather	Clear
Top oil temperature	°C	Humidity	89 %

Comments

Standard test

Block 1: injection at H

Corr. temperature	°C
Corr. factor	1

No.	Meas.	Test mode	Freq.	V out	I out	Watt losses	PF meas	PF corr	Cap. meas	Assessment
1	ICH+ICHL	GST	60.00 Hz	2.00 kV	1.74 mA	927.39 mW	26.6176 %	26.6176 %	2224.1 pF	Pass
2	ICH (V)	GSTg-A	60.00 Hz	2.00 kV	0.39 mA	551.29 mW	71.2689 %	71.2689 %	359.0 pF	Pass
3	ICHL (V)	UST-A	60.00 Hz	2.00 kV	1.45 mA	546.44 mW	18.8566 %	18.8566 %	1887.7 pF	Pass

Block 2: injection at X

Corr. temperature	°C
Corr. factor	1

No.	Meas.	Test mode	Freq.	V out	I out	Watt losses	PF meas	PF corr	Cap. meas	Assessment
4	ICL+ICLH	GST	60.00 Hz	0.10 kV	0.25 mA	10.34 mW	40.8639 %	40.8639 %	6091.5 pF	Pass
5	ICL (V)	GSTg-A	60.00 Hz	0.10 kV	0.17 mA	7.77 mW	45.0110 %	45.0110 %	4111.2 pF	Pass
6	ICLH (V)	UST-A	60.00 Hz	0.10 kV	0.07 mA	1.47 mW	20.0091 %	20.0091 %	1919.4 pF	Pass

Test set information

Model	Serial number	Calibration date
TESTRANO 600	LN612B	2024-07-08
CP TD12	LN574C	2024-07-27

TTR H-X

Comment

--

Measurement settings

Test voltage	120 V
Test frequency	60.00 Hz
Tap changer under test	DETC

Ratio	TTR*
-------	------

Measurements (sorted by tap)

Tap	Phase	Nom. Ratio	$V_{prim} (L-L)$	I_{prim}	$V_{sec} (L-L)$	V_{phase}	TTR*	Ratio dev	Assessment
4	A	14.6358	119.85 V	86.814 mA	14.15 V	30.01 °	14.6697	0.23 %	Pass
4	B	14.6358	119.86 V	142.081 mA	14.15 V	30.01 °	14.6728	0.25 %	Pass
4	C	14.6358	119.85 V	101.439 mA	14.15 V	30 °	14.6712	0.24 %	Pass

Graphs for standard test

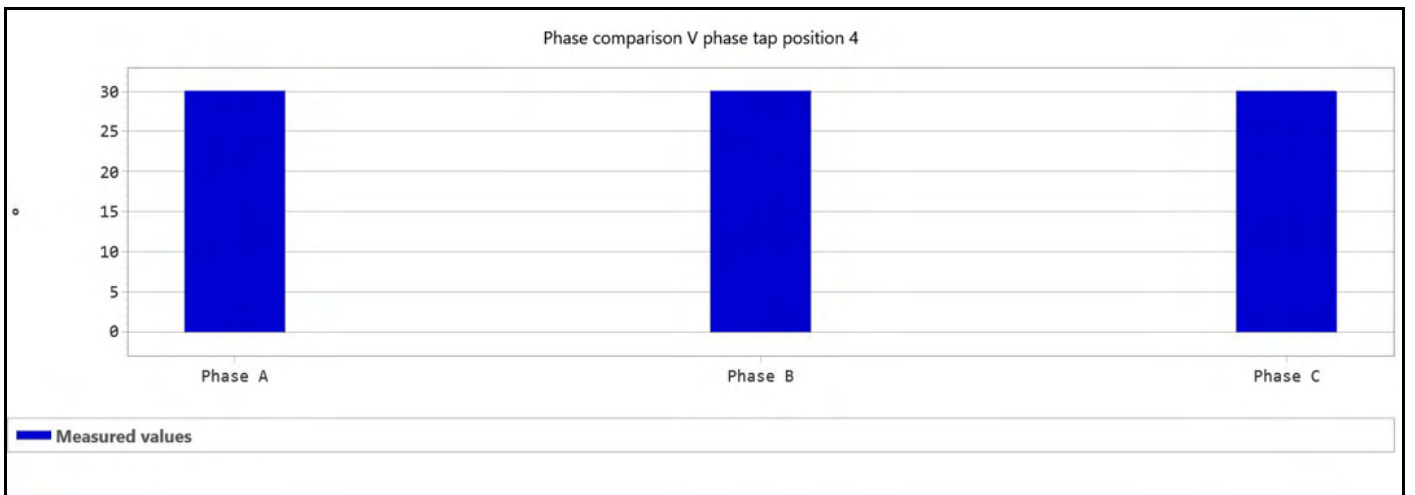
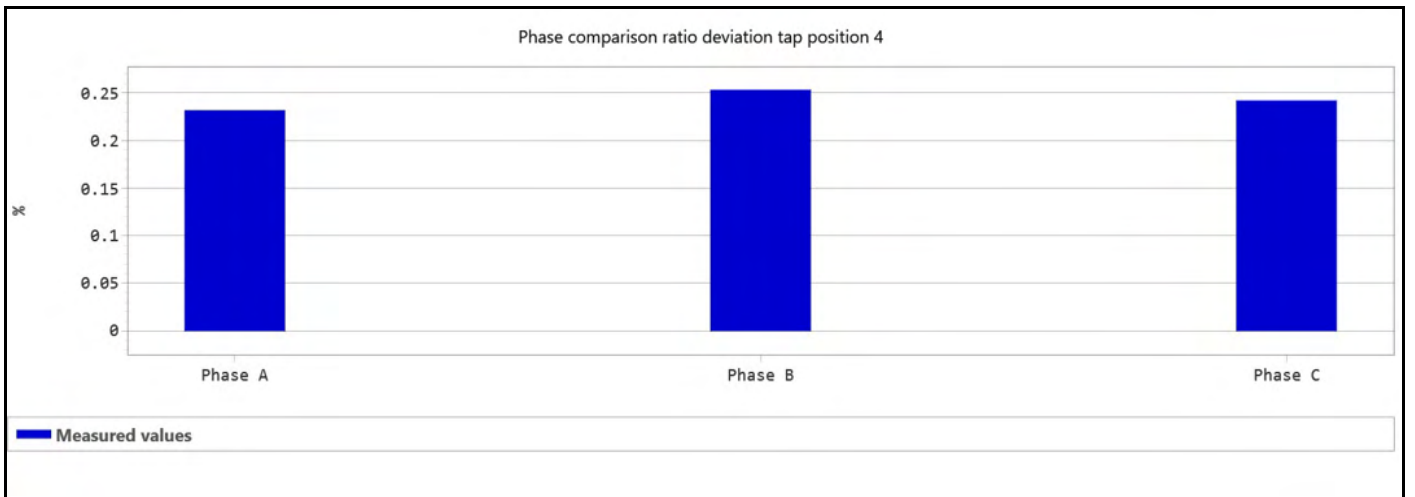
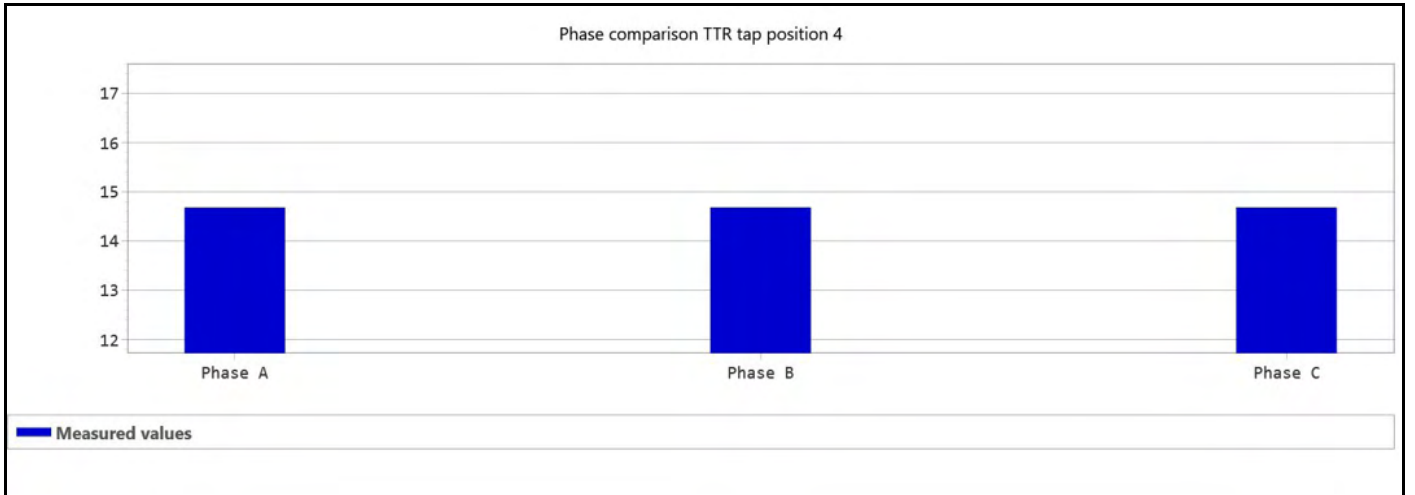

Graph for exciting current

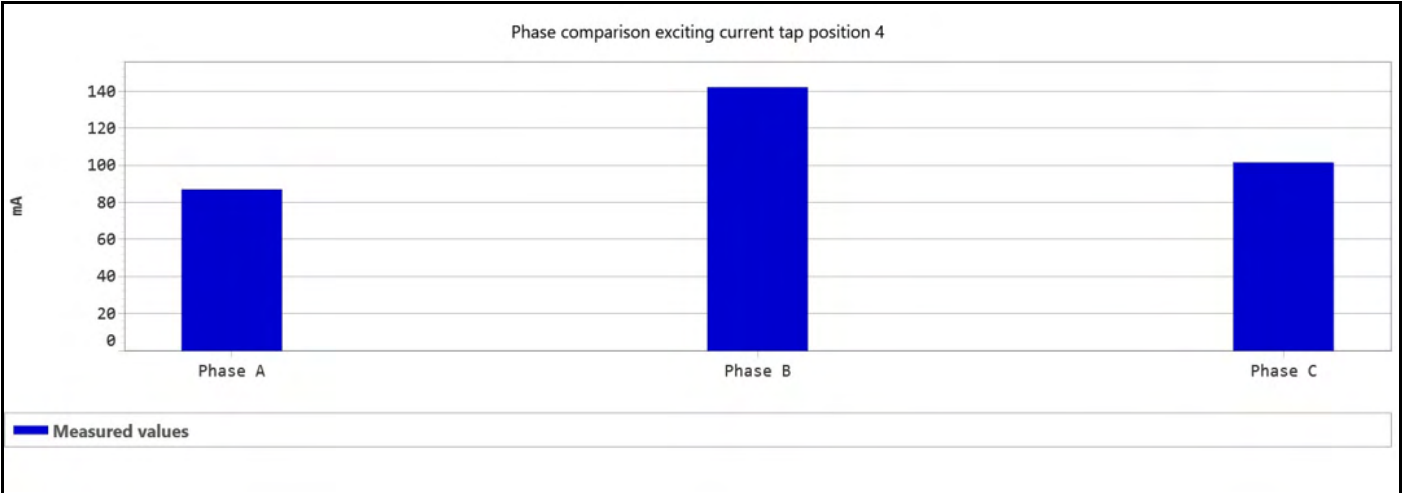

Test set information

Model	Serial number	Calibration date
TESTRANO 600	LN612B	2024-07-08
CP TD12	LN574C	2024-07-27

DC Winding Resistance H

Comment

--

Measurement settings

Test current	5 A	Tap changer under test	DETC
Output mode	16 A @ 340 V		
	1 ph.		

Winding temperature	20 °C
Reference temperature	75 °C
Temp. corr. factor (K)	1.216

Automatic result	True
Settling time (At)	5 s
Tolerance R dev	0.1 %
Recording time	200.0 ms

Tap	A (H1 - H3)			B (H2 - H1)			C (H3 - H2)		
	<i>R meas</i>	<i>R dev</i>	<i>R corr</i>	<i>R meas</i>	<i>R dev</i>	<i>R corr</i>	<i>R meas</i>	<i>R dev</i>	<i>R corr</i>
4	3.308 mΩ	31.605 %	4.023 mΩ	36.316 mΩ	0.033 %	44.164 mΩ	36.351 mΩ	0.227 %	44.207 mΩ

Graphs for standard test

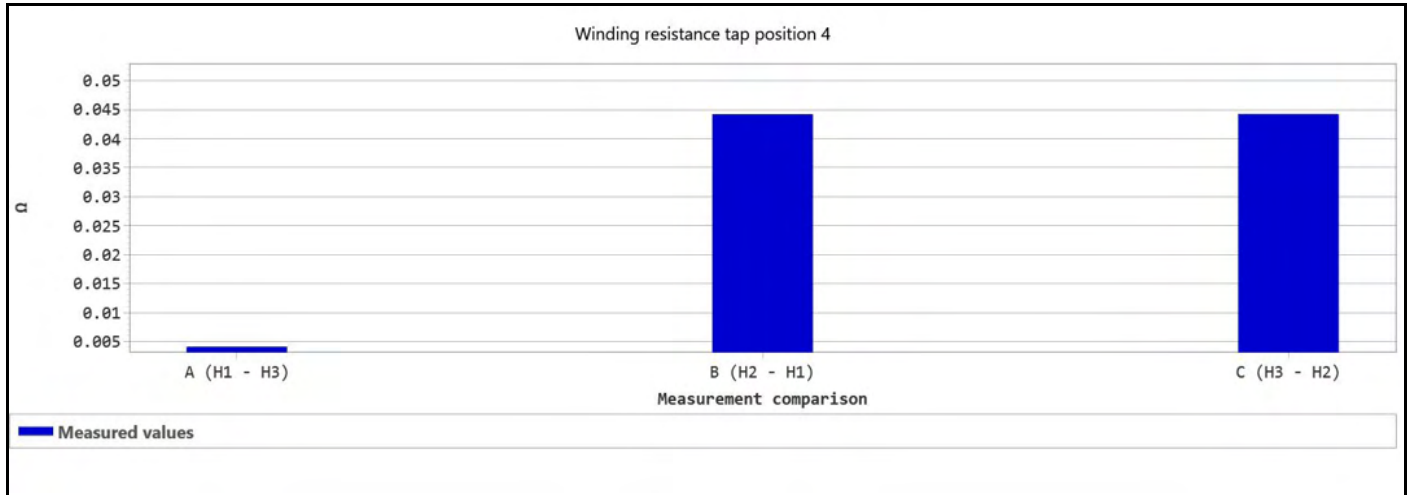

Test set information

Model	Serial number	Calibration date
TESTRANO 600	LN612B	2024-07-08
CP TD12	LN574C	2024-07-27

DC Winding Resistance X

Comment

--

Measurement settings

Test current	10 A
Output mode	33 A @ 56 V
	3 ph.
Measurement	L-N

Winding temperature	20 °C
Reference temperature	75 °C
Temp. corr. factor (K)	1.216

Automatic result	True
Settling time (At)	5 s
Tolerance R dev	0.1 %
Recording time	200.0 ms

A (X1 - X0)			B (X2 - X0)			C (X3 - X0)		
<i>R meas</i>	<i>R dev</i>	<i>R corr</i>	<i>R meas</i>	<i>R dev</i>	<i>R corr</i>	<i>R meas</i>	<i>R dev</i>	<i>R corr</i>
228.913 $\mu\Omega$	0.050 %	278.383 $\mu\Omega$	207.472 $\mu\Omega$	0.078 %	252.309 $\mu\Omega$	223.447 $\mu\Omega$	0.038 %	271.736 $\mu\Omega$

Graphs for standard test

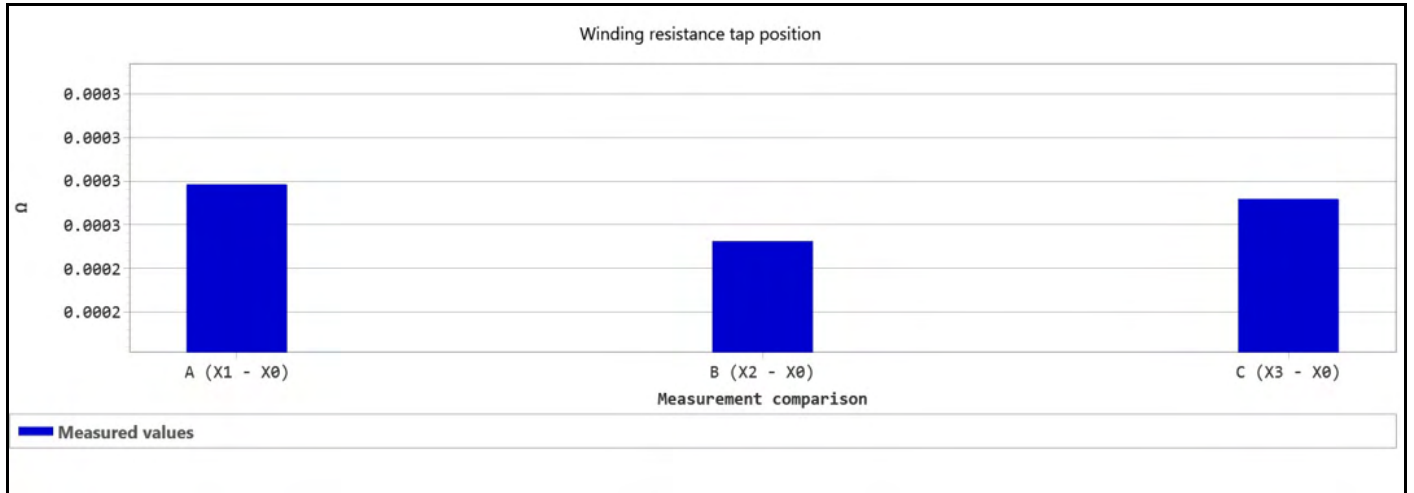

TESTING REPORTS FOR 52-T2

52 - T2 - SF-6 Breaker



Client	Orange Cogen	624942 - 52 - T2	
Execution date	9/30/2024	Reason of the job	Routine
Tested by	Falchetti, Matthew	Location	Orange Cogen
Approved by		Asset	Circuit breaker
Report ID	2	Asset type	Dead tank SF6 breaker
Report issue date	10/9/2024 12:16:56 PM	Asset serial number	48325-1
Work order		Manufacturer	Siemens

Summary

Performed tests	Assessment
C Timing	Pass
O Timing	Pass
CO Timing	Pass
OC Timing	Pass
O-CO Timing	Pass
Bushing - Energized Collar	Pass
Circuit Breaker PF & CAP	Pass

Overall Assessment	No Faults – Passed
--------------------	--------------------

Tested by:
Matthew Falchetti / Andrew Kirk

Approved by:
Matthew Falchetti

Location & company information			
Location		Company	
Name	Orange Cogen	Company	TRC Companies
Region		Department	
Division	TRC Companies	Address	
Area		City	Lakeland
Plant	Orange Cogen	State/Province	Florida
Address	1901 S. Clear Springs Rd	Postal code	
City	Bartow	Country	United States
State/Province	Florida	Phone No.	
Postal code	33830	Fax No.	
Country	United States	E-mail	

Geo coordinates	
-----------------	--

Contact person	
Name	David Coursen
Phone No. 1	
Phone No. 2	
Fax No.	
E-mail	

Comment

Dead tank SF6 breaker nameplate data			
Serial number	48325-1	No. of interrupters p. phase	1
Manufacturer	Siemens	Pole operation	Ganged
Manufacturing year	1994	Pre-insertion resistors	No
Manufacturer type	SPS-72.5-40-1	PIR value	Ω
Asset system code		Grading capacitors	Yes
Apparatus ID	52-T2	Capacitor value	pF
Feeder		Interrupting medium	SF6
No. of phases	3	Tank type	Dead tank

Comment

Ratings

Rated frequency	60.00 Hz
Rated voltage L-L	72.5 kV
Rated current	2000.0 A
Rated SC breaking current	40.0 kA
Short-circuit nominal duration	s
Rated insul. level L-G (BIL)	350.0 kV
Rated interrupting time	ms
Interrupting duty cycle	
Rated power at closing	W
Rated power at opening	W
Rated power at motor charge	W

Contact system

Total travel	in
Damping time	ms
Nozzle length	in

Others

Total weight with gas	4370 lbs
Weight of gas	15 lbs
Volume of gas	gals
Rated gas pressure	80.00 psi @ 21 °C

Spring Operating mechanism nameplate data

Serial No.	48325-1
Manufacturer	Siemens
Manufacturer type	SPS-SE
Manufacturing year	1994
Asset system code	52 -T2

Component	Rated voltage	Rated current	Frequency	
Trip coil 1	135.0 V	A	Hz	DC
Close coil 1	135.0 V	A	Hz	DC
Auxiliary circuits	V	A	Hz	DC
Motor	135.0 V	A	Hz	DC

Bushings nameplate data

Pos.	Serial No.	Manufact.	Man. year	Voltage L-ground	Max. system voltage	Rated current	Insul. level LL
1		LAPP		72.5 kV	72.5 kV	2000.0 A	V
2		LAPP		72.5 kV	72.5 kV	2000.0 A	V
3		LAPP		72.5 kV	72.5 kV	2000.0 A	V
4		LAPP		72.5 kV	72.5 kV	2000.0 A	V
5		LAPP		72.5 kV	72.5 kV	2000.0 A	V
6		LAPP		72.5 kV	72.5 kV	2000.0 A	V

Pos.	Cap. (C1)	PF (C1)	Cap. (C2)	PF (C2)	Insulation type	Tap type
1	pF	%	pF	%	Porcelain dry type	Without tap

Pos.	Cap. (C1)	PF (C1)	Cap. (C2)	PF (C2)	Insulation type	Tap type
2	pF	%	pF	%	Porcelain dry type	Without tap
3	pF	%	pF	%	Porcelain dry type	Without tap
4	pF	%	pF	%	Porcelain dry type	Without tap
5	pF	%	pF	%	Porcelain dry type	Without tap
6	pF	%	pF	%	Porcelain dry type	Without tap

Test set information

Model	Serial number	Calibration date
CIBANO 500	JN863V	2024-05-28
CB TN3	KN628D	2024-06-03

Global test conditions

Weather	Clear	Humidity	94 %
Unit location	Outside	Ambient temperature	24 °C

Operations counter

Counter reading found	403
Counter reading left	

Test set information

Model	Serial number	Calibration date
CIBANO 500	JN863V	2024-05-28
CB TN3	KN628D	2024-06-03

C Timing

Execution date/Time	9/30/2024 10:21:08 AM	
Sequence	C	
Coil supply voltage	135.0 V DC	
Time calculation	According to IEC 62271-100	
Sample rate	10 kHz	

Transducer settings

CB TN3, Channel 1	5.0 V - 1.9224 mil (digital)
-------------------	------------------------------

Main, resistive and auxiliary contacts

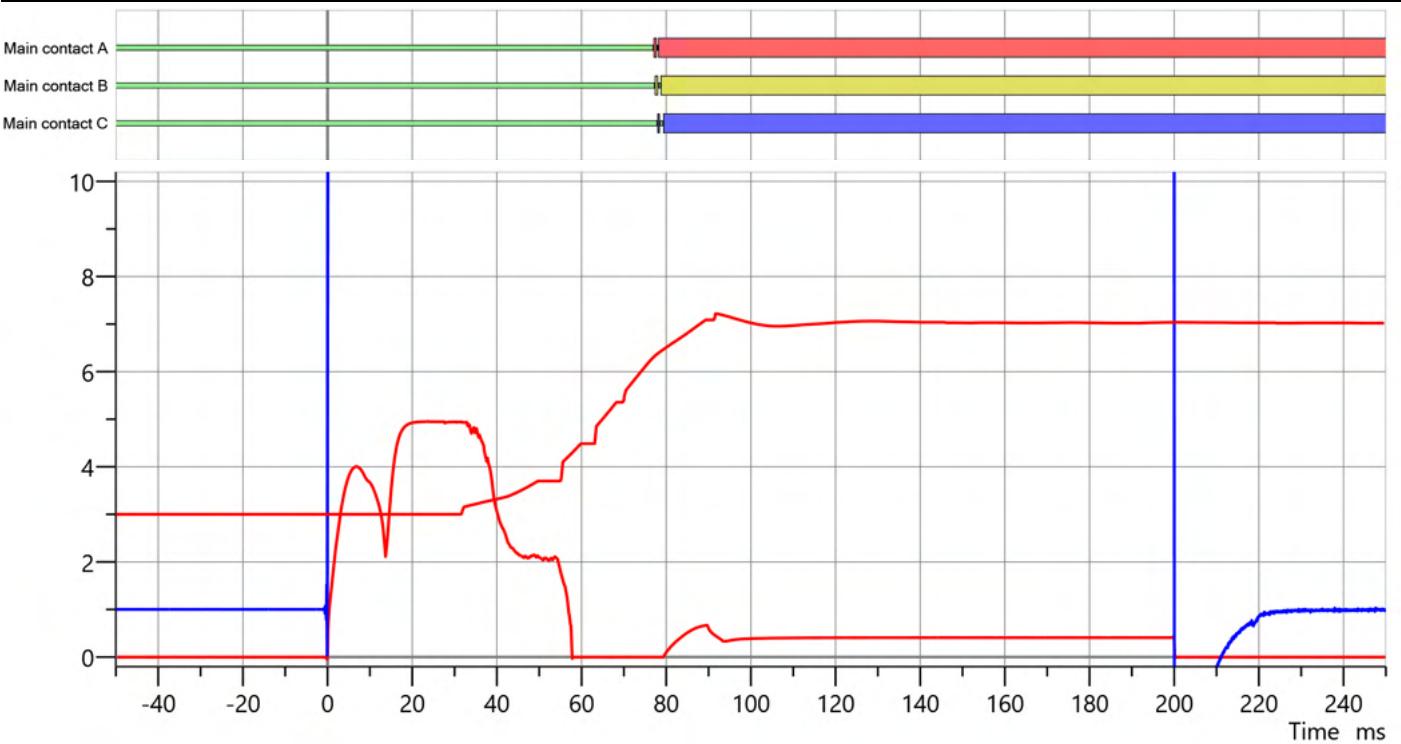

Label	Unit/div.	Y-Axis pos.	Label	Unit/div.	Y-Axis pos.		
Close coil (A)	■	1.00 A	0.00	Channel 1 (travel)	■	1.22 in	3.00
Close coil (V)	■	10.00 V	1.00				

Operating times

Meas.	Closing time (ms)	Closing sync. (ms)	Assessment
Breaker	77.90	0.90	Pass
A	77.00		Pass
Main contact A	77.00		Pass
B	77.30		Pass
Main contact B	77.30		Pass
C	77.90		Pass
Main contact C	77.90		Pass

Assessment Limits	t min	t max
Closing time	70.00 ms	90.00 ms
Closing sync. (contacts within a phase)	ms	ms
Closing sync. (between breaker phases)	ms	ms

Contact travel characteristics

Module	Channel	Total travel	Over-travel	Rebound	Damping dist. BLG	Damping time BLG	Assessment
CB TN3	Channel 1	4.91 in	0.24 in	0.08 in	in	ms	N. rated

Assessment Limits	d min	d max
Total travel, TT	in	in
Over-travel (Close), OT	in	in
Rebound (Close), RB	in	in
Contact wipe (Close), CW	in	in

Assessment Limits	Minimum	Maximum
Damping distance (Close)	in	in
Damping time (Close)	ms	ms

Main contact characteristics

Main contact	Travel data	Contact wipe	Reaction time	PIR close time	Bounce time	Bounce count	Assessment
Main contact A	Channel 1	0.87 in	31.80 ms	ms	1.10 ms	1	N. rated
Main contact B	No data		ms	ms	1.40 ms	1	N. rated
Main contact C	No data		ms	ms	1.40 ms	1	N. rated

Assessment Limits	Minimum	Maximum
Bounce time	ms	ms
Bounce count		
Reaction time	ms	ms

Coil characteristics

	Peak current (A)	Average current (A)	Average voltage (V)	Resistance (Ω)	Assessment
Close	4.96	3.71	132.50	35.71	N. rated

Assessment Limits	Minimum	Maximum
Peak close coil current	A	A
Peak trip coil current	A	A
Average close coil current	A	A
Average trip coil current	A	A
Average close coil voltage	V	V
Average trip coil voltage	V	V
Close coil resistance	Ω	Ω
Trip coil resistance	Ω	Ω

Comments

Megger - Closed

A phase - 341 G

B phase - 400 G

C phase - 207 G

DLRO - Closed

A phase - 94.28 micro

B phase - 99.82 micro

C phase - 97.20 micro

Test set information

Model	Serial number	Calibration date
CIBANO 500	JN863V	2024-05-28
CB TN3	KN628D	2024-06-03

O Timing

Execution date/Time	9/30/2024 10:20:21 AM	
Sequence	O	
Coil supply voltage	135.0 V DC	
Time calculation	According to IEC 62271-100	
Sample rate	10 kHz	

Transducer settings

CB TN3, Channel 1	5.0 V - 1.9224 mil (digital)
-------------------	------------------------------

Main, resistive and auxiliary contacts

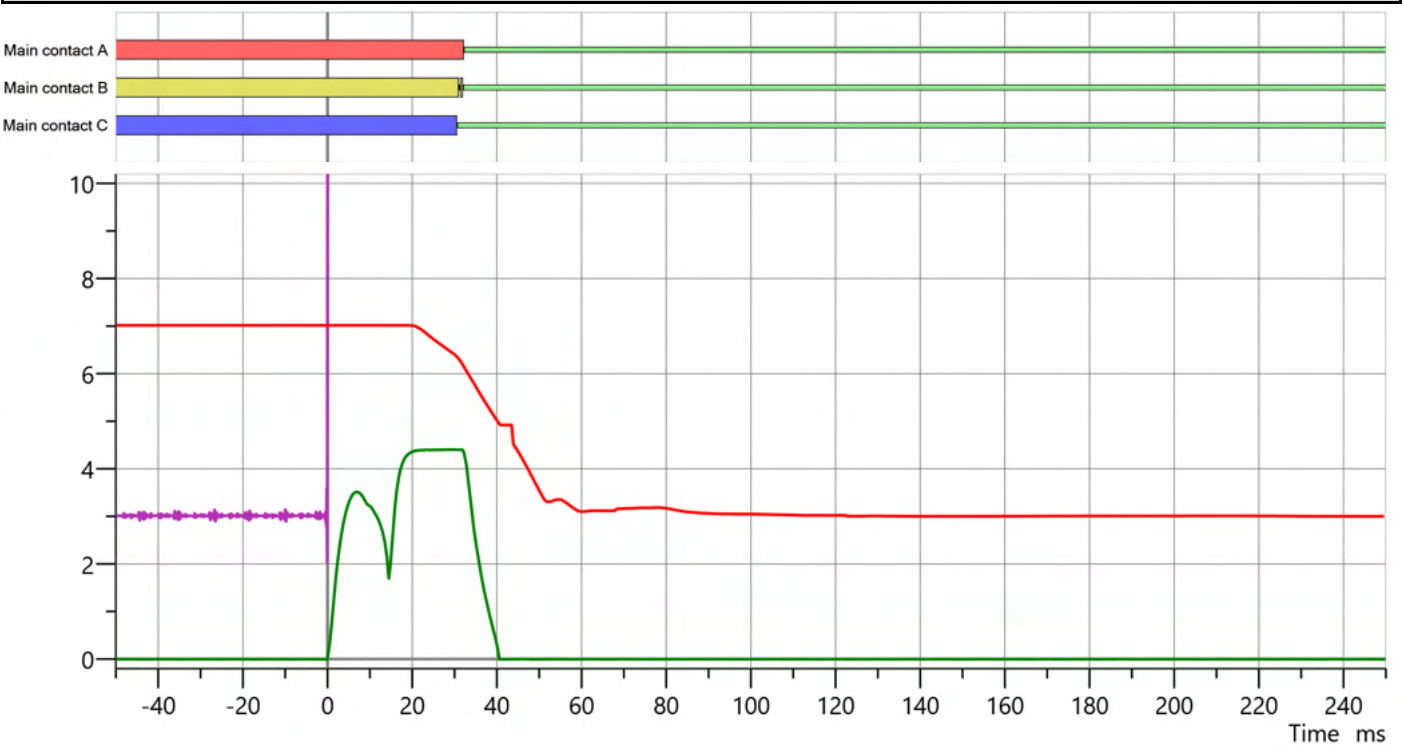

Label	Unit/div.	Y-Axis pos.	Label	Unit/div.	Y-Axis pos.		
Trip coil (A)	■	1.00 A	0.00	Channel 1 (travel)	■	1.22 in	3.00
Trip coil (V)	■	10.00 V	3.00				

Operating times

Meas.	Opening time (ms)	Opening sync. (ms)	Assessment
Breaker	32.20	1.60	Pass
A	32.20		Pass
Main contact A	32.20		Pass
B	32.00		Pass
Main contact B	32.00		Pass
C	30.60		Pass
Main contact C	30.60		Pass

Assessment Limits	t min	t max
Opening time	ms	32.00 ms
Opening sync. (contacts within a phase)	ms	ms
Opening sync. (between breaker phases)	ms	ms

Contact travel characteristics

Module	Channel	Total travel	Over-travel	Rebound	Damping distance	Assessment
CB TN3	Channel 1	4.90 in	0.00 in	0.01 in	in	N. rated

Assessment Limits	d min	d max
Total travel, TT	in	in
Over-travel (Trip), OT	in	in
Rebound (Trip), RB	in	in
Contact wipe (Trip), CW	in	in

Assessment Limits	Minimum	Maximum
Damping distance (Trip)	in	in

Main contact characteristics

Main contact	Travel data	Contact wipe	Reaction time	PIR close time	Bounce time	Bounce count	Assessment
Main contact A	Channel 1	1.06 in	21.30 ms	ms	0.00 ms	0	N. rated
Main contact B	No data		ms	ms	1.00 ms	1	N. rated
Main contact C	No data		ms	ms	0.00 ms	0	N. rated

Assessment Limits	Minimum	Maximum
Bounce time	ms	ms
Bounce count		
Reaction time	ms	ms

Coil characteristics

	Peak current (A)	Average current (A)	Average voltage (V)	Resistance (Ω)	Assessment
Trip A	4.40	3.54	132.44	37.41	N. rated

Assessment Limits	Minimum	Maximum
Peak close coil current	A	A
Peak trip coil current	A	A
Average close coil current	A	A
Average trip coil current	A	A
Average close coil voltage	V	V
Average trip coil voltage	V	V
Close coil resistance	Ω	Ω
Trip coil resistance	Ω	Ω

Comments

Open Megger - Test

A Phase - 1.64 T

B Phase - 1.20 T

C Phase - 1.20 T

Test set information

Model	Serial number	Calibration date
CIBANO 500	JN863V	2024-05-28
CB TN3	KN628D	2024-06-03

CO Timing

Execution date/Time	9/30/2024 10:23:06 AM	
Sequence	CO	
Coil supply voltage	135.0 V DC	
Sample rate	10 kHz	

Transducer settings

CB TN3, Channel 1	5.0 V - 1.9224 mil (digital)
-------------------	------------------------------

Main, resistive and auxiliary contacts

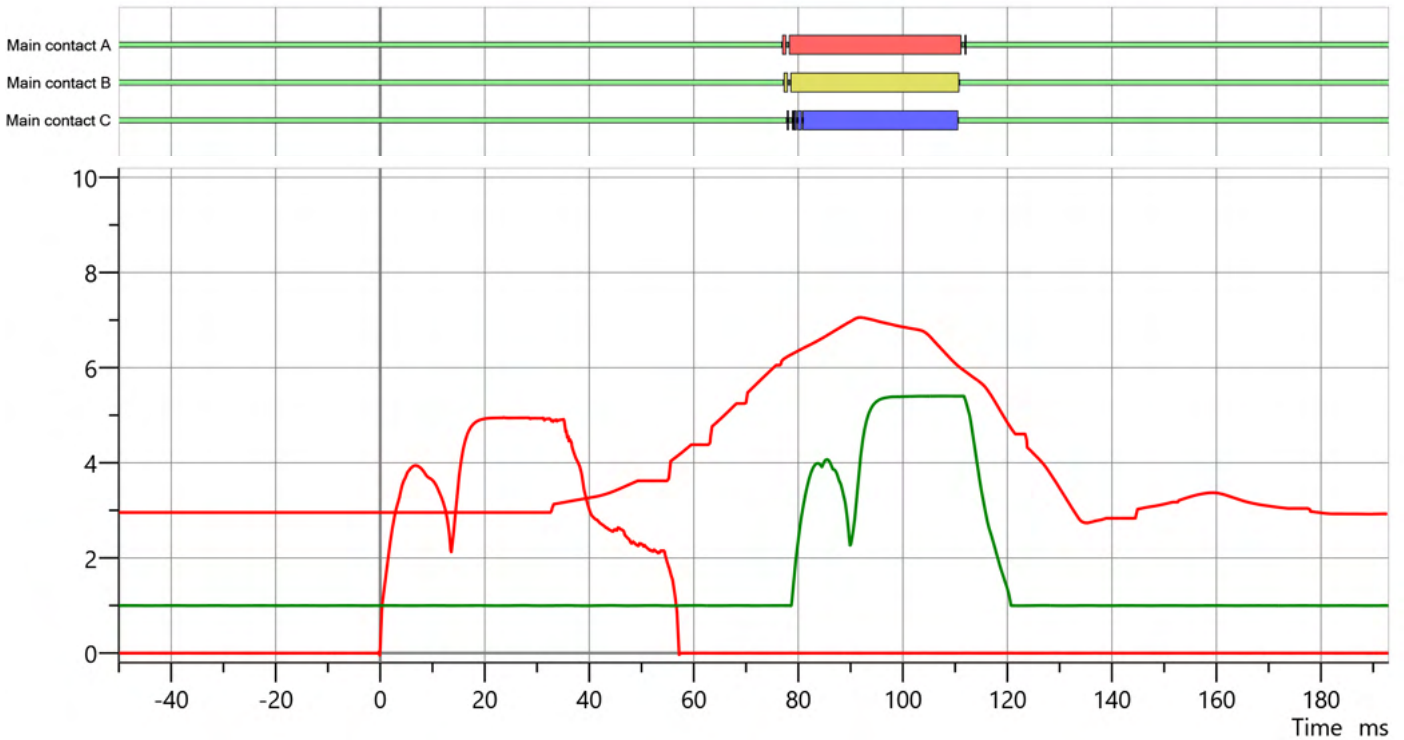

Label	Unit/div.	Y-Axis pos.	Label	Unit/div.	Y-Axis pos.		
Close coil (A)	■	1.00 A	0.00	Channel 1 (travel)	■	1.26 in	2.74
Trip coil (A)	■	1.00 A	1.00				

Operating times

Meas.	Closing time (ms)	Closing sync. (ms)	Close-Open time 1 (ms)	Assessment
Breaker	77.80	0.90	35.10	Pass
A	76.90		35.10	Pass
Main contact A	76.90		35.10	Pass
B	77.20		33.60	Pass
Main contact B	77.20		33.60	Pass
C	77.80		32.80	Pass
Main contact C	77.80		32.80	Pass

Assessment Limits	t min	t max
Closing time	70.00 ms	90.00 ms
Closing sync. (contacts within a phase)	ms	ms
Closing sync. (between breaker phases)	ms	ms
Close-Open time	ms	ms

Coil characteristics

	Peak current (A)	Average current (A)	Average voltage (V)	Resistance (Ω)	Assessment
Close	4.95				N. rated
Trip A	4.40				N. rated

Assessment Limits	Minimum	Maximum
Peak close coil current	A	A
Peak trip coil current	A	A

Comments

Test set information

Model	Serial number	Calibration date
CIBANO 500	JN863V	2024-05-28
CB TN3	KN628D	2024-06-03

OC Timing

Execution date/Time	9/30/2024 10:22:18 AM	
Sequence	OC	
Coil supply voltage	135.0 V DC	
Sample rate	10 kHz	

Transducer settings

CB TN3, Channel 1	5.0 V - 1.9224 mil (digital)
-------------------	------------------------------

Main, resistive and auxiliary contacts

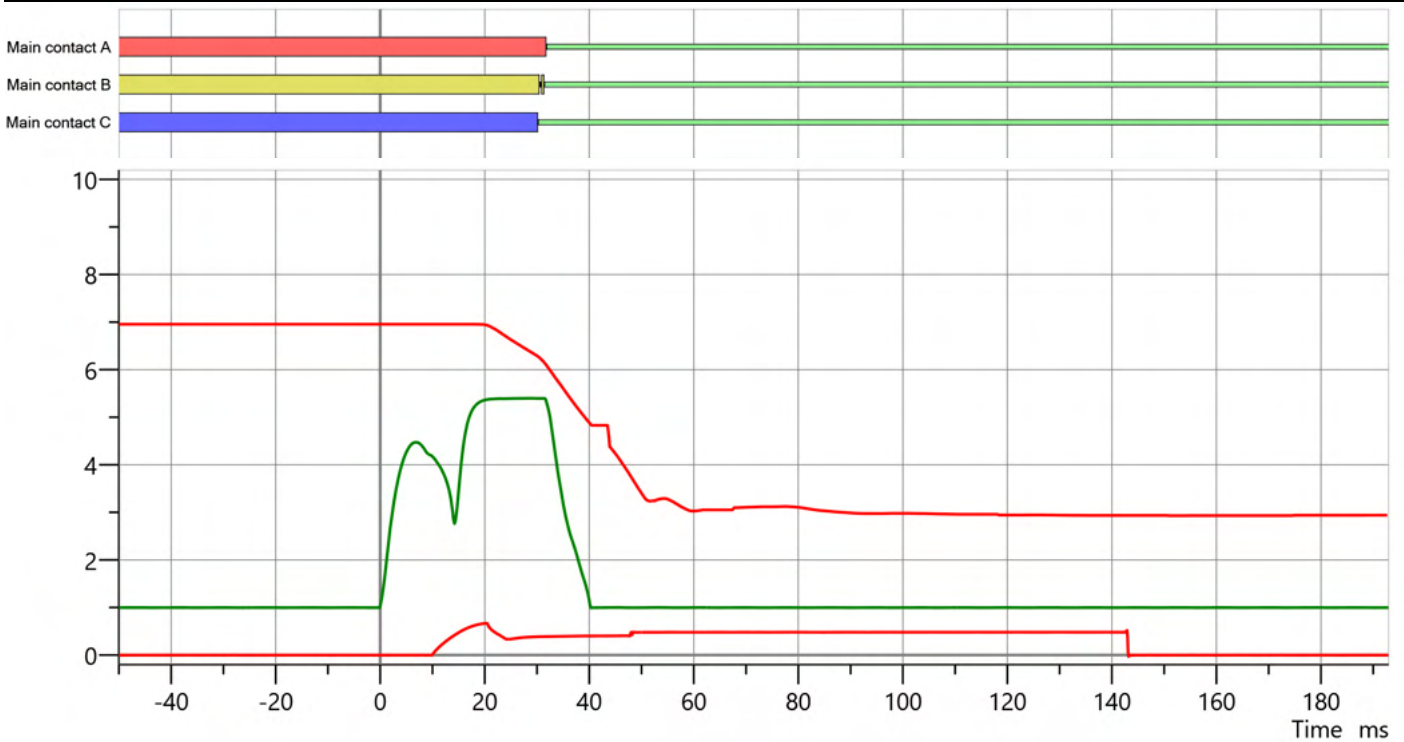

Label	Unit/div.	Y-Axis pos.	Label	Unit/div.	Y-Axis pos.		
Close coil (A)	■	1.00 A	0.00	Channel 1 (travel)	■	1.22 in	2.93
Trip coil (A)	■	1.00 A	1.00				

Operating times

Meas.	Opening time (ms)	Opening sync. (ms)	Reclosing time (ms)	Assessment
Breaker	31.80	1.60		Pass
A	31.80			Pass
Main contact A	31.80			Pass
B	31.40			Pass
Main contact B	31.40			Pass
C	30.20			Pass
Main contact C	30.20			Pass

Assessment Limits	t min	t max
Opening time	ms	32.00 ms
Opening sync. (contacts within a phase)	ms	ms
Opening sync. (between breaker phases)	ms	ms
Reclosing time	ms	200.00 ms

Coil characteristics

	Peak current (A)	Average current (A)	Average voltage (V)	Resistance (Ω)	Assessment
Close	0.67				N. rated
Trip A	4.40				N. rated

Assessment Limits	Minimum	Maximum
Peak close coil current	A	A
Peak trip coil current	A	A

Comments

Test set information

Model	Serial number	Calibration date
CIBANO 500	JN863V	2024-05-28
CB TN3	KN628D	2024-06-03

O-CO Timing

Execution date/Time	9/30/2024 10:24:10 AM	
Sequence	O-CO	
Coil supply voltage	135.0 V DC	
Sample rate	10 kHz	

Transducer settings

CB TN3, Channel 1	5.0 V - 1.9224 mil (digital)
-------------------	------------------------------

Main, resistive and auxiliary contacts

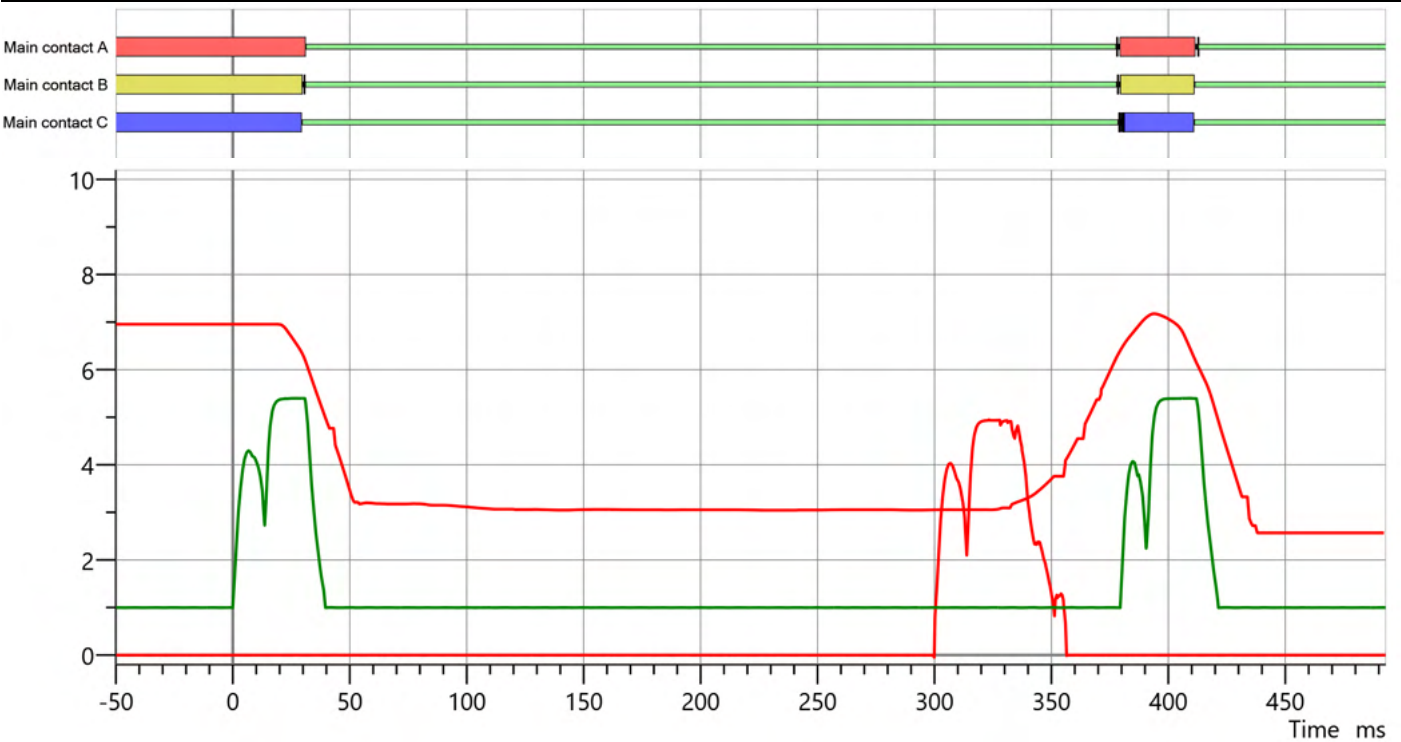

Label	Unit/div.	Y-Axis pos.	Label	Unit/div.	Y-Axis pos.		
Close coil (A)	■	1.00 A	0.00	Channel 1 (travel)	■	1.26 in	2.57
Trip coil (A)	■	1.00 A	1.00				

Operating times

Meas.	Opening time (ms)	Opening sync. (ms)	Closing time (ms)	Closing sync. (ms)	Open-Close time (ms)	Close-Open time 1 (ms)	Assessment
Breaker	31.20	1.70	78.60	0.90	346.50	34.90	Pass
A	31.20		77.70		346.50	34.90	Pass
Main contact A	31.20		77.70		346.50	34.90	Pass
B	30.90		78.00		347.10	33.20	Pass
Main contact B	30.90		78.00		347.10	33.20	Pass
C	29.50		78.60		349.10	32.40	Pass
Main contact C	29.50		78.60		349.10	32.40	Pass

Assessment Limits	t min	t max
Opening time	ms	32.00 ms
Opening sync. (contacts within a phase)	ms	ms
Opening sync. (between breaker phases)	ms	ms
Closing time	70.00 ms	90.00 ms
Closing sync. (contacts within a phase)	ms	ms
Closing sync. (between breaker phases)	ms	ms
Open-Close time	ms	ms
Close-Open time	ms	ms

Coil characteristics

	Peak current (A)	Average current (A)	Average voltage (V)	Resistance (Ω)	Assessment
Close	4.95				N. rated
Trip A	4.40				N. rated

Assessment Limits	Minimum	Maximum
Peak close coil current	A	A
Peak trip coil current	A	A

Comments

Bushing - Energized Collar

Ambient temperature	24 °C	Weather	Clear
		Humidity	94 %

Comments

--

Standard test

No.	Meas.	Test mode	Freq.	V out	I out	Watt losses	Assessment
1	Bushing 1	UST-A	60.00 Hz	10.00 kV	0.06 mA	37.65 mW	Pass
2	Bushing 2	UST-A	60.00 Hz	10.00 kV	0.07 mA	73.04 mW	Pass
3	Bushing 3	UST-A	60.00 Hz	10.00 kV	0.06 mA	42.49 mW	Pass
4	Bushing 4	UST-A	60.00 Hz	10.00 kV	0.07 mA	75.29 mW	Pass
5	Bushing 5	UST-A	60.00 Hz	10.00 kV	0.06 mA	34.52 mW	Pass
6	Bushing 6	UST-A	60.00 Hz	10.00 kV	0.06 mA	42.21 mW	Pass

Circuit Breaker PF & CAP

Ambient temperature	24 °C	Weather	Clear
		Humidity	94 %

Comments

--

Standard test

Meas.	Position	Test mode	Freq.	V out	I out	Watt losses	PF meas	PF corr	Cap. meas	Assessment
C1G	Open	GST	60.00 Hz	10.00 kV	0.40 mA	15.70 mW	0.3902 %	0.3902 %	103.7 pF	Pass
C2G	Open	GST	60.00 Hz	10.00 kV	0.41 mA	18.45 mW	0.4491 %	0.4491 %	106.0 pF	Pass
C3G	Open	GST	60.00 Hz	10.00 kV	0.41 mA	20.33 mW	0.4903 %	0.4903 %	107.0 pF	Pass
C4G	Open	GST	60.00 Hz	10.00 kV	0.41 mA	17.74 mW	0.4323 %	0.4323 %	105.8 pF	Pass
C5G	Open	GST	60.00 Hz	10.00 kV	0.41 mA	17.12 mW	0.4218 %	0.4218 %	104.7 pF	Pass
C6G	Open	GST	60.00 Hz	10.00 kV	0.41 mA	14.83 mW	0.3620 %	0.3620 %	105.6 pF	Pass
C12	Open	UST-A	60.00 Hz	10.00 kV	0.00 mA	0.58 mW	0.0439 %	0.0439 %	0.8 pF	Pass
C34	Open	UST-A	60.00 Hz	10.00 kV	0.00 mA	0.07 mW	0.2581 %	0.2581 %	0.8 pF	Pass
C56	Open	UST-A	60.00 Hz	10.00 kV	0.00 mA	0.65 mW	0.2330 %	0.2330 %	0.8 pF	Pass

TESTING REPORTS FOR 52-T1

52 - T1 - SF-6 Breaker



Client		624946 - 52 - T1	
Execution date	10/3/2024	Reason of the job	Routine
Tested by	Falchetti, Matthew	Location	Orange Cogen
Approved by		Asset	Circuit breaker
Report ID	2	Asset type	Dead tank SF6 breaker
Report issue date	10/9/2024 12:22:20 PM	Asset serial number	48326-2
Work order		Manufacturer	Siemens

Summary
DLRO Readings - Closed Breaker A - phase - 100 micro B - phase - 104 micro C - phase - 99 micro

Performed tests	Assessment
C Timing	Pass
O Timing	Pass
CO Timing	Pass
Bushing - Energized Collar	Pass
Circuit Breaker PF & CAP	Pass

Overall Assessment	No Faults - Passed
--------------------	--------------------

Tested by:
Matthew Falchetti / Andrew Kirk

Approved by:
Matthew Falchetti

Location & company information

Location		Company	
Name	Orange Cogen	Company	TRC Companies
Region		Department	
Division	TRC Companies	Address	
Area		City	Lakeland
Plant	Orange Cogen	State/Province	Florida
Address	1901 S. Clear Springs Rd	Postal code	
City	Bartow	Country	United States
State/Province	Florida	Phone No.	
Postal code	33830	Fax No.	
Country	United States	E-mail	

Geo coordinates	
-----------------	--

Contact person	
Name	David Coursen
Phone No. 1	
Phone No. 2	
Fax No.	
E-mail	

Comment

Dead tank SF6 breaker nameplate data

Serial number	48326-2	No. of interrupters p. phase	1
Manufacturer	Siemens	Pole operation	Ganged
Manufacturing year	1994	Pre-insertion resistors	No
Manufacturer type	SPS-72.5-40-1	PIR value	Ω
Asset system code		Grading capacitors	Yes
Apparatus ID	52-T1	Capacitor value	pF
Feeder		Interrupting medium	SF6
No. of phases	3	Tank type	Dead tank

Comment

Ratings

Rated frequency	60.00 Hz
Rated voltage L-L	72.5 kV
Rated current	2000.0 A
Rated SC breaking current	40.0 kA
Short-circuit nominal duration	s
Rated insul. level L-G (BIL)	350.0 kV
Rated interrupting time	ms
Interrupting duty cycle	
Rated power at closing	W
Rated power at opening	W
Rated power at motor charge	W

Contact system

Total travel	in
Damping time	ms
Nozzle length	in

Others

Total weight with gas	4370 lbs
Weight of gas	15 lbs
Volume of gas	gals
Rated gas pressure	80.00 psi @ 21 °C

Spring Operating mechanism nameplate data

Serial No.	48326-2
Manufacturer	Siemens
Manufacturer type	SPS-SE
Manufacturing year	1994
Asset system code	52 -T1

Component	Rated voltage	Rated current	Frequency	
Trip coil 1	135.0 V	A	Hz	DC
Close coil 1	135.0 V	A	Hz	DC
Auxiliary circuits	V	A	Hz	DC
Motor	135.0 V	A	Hz	DC

Bushings nameplate data

Pos.	Serial No.	Manufact.	Man. year	Voltage L-ground	Max. system voltage	Rated current	Insul. level LL
1		LAPP		72.5 kV	72.5 kV	2000.0 A	V
2		LAPP		72.5 kV	72.5 kV	2000.0 A	V
3		LAPP		72.5 kV	72.5 kV	2000.0 A	V
4		LAPP		72.5 kV	72.5 kV	2000.0 A	V
5		LAPP		72.5 kV	72.5 kV	2000.0 A	V
6		LAPP		72.5 kV	72.5 kV	2000.0 A	V

Pos.	Cap. (C1)	PF (C1)	Cap. (C2)	PF (C2)	Insulation type	Tap type
1	pF	%	pF	%	Porcelain dry type	Without tap

Pos.	Cap. (C1)	PF (C1)	Cap. (C2)	PF (C2)	Insulation type	Tap type
2	pF	%	pF	%	Porcelain dry type	Without tap
3	pF	%	pF	%	Porcelain dry type	Without tap
4	pF	%	pF	%	Porcelain dry type	Without tap
5	pF	%	pF	%	Porcelain dry type	Without tap
6	pF	%	pF	%	Porcelain dry type	Without tap

Test set information

Model	Serial number	Calibration date
CIBANO 500	JN863V	2024-05-28
CB TN3	KN628D	2024-06-03

Global test conditions

Weather	Clear	Humidity	93 %
Unit location	Outside	Ambient temperature	24 °C

Operations counter

Counter reading found	00335
Counter reading left	

Test set information

Model	Serial number	Calibration date
CIBANO 500	JN863V	2024-05-28
CB TN3	KN628D	2024-06-03

C Timing

Execution date/Time	10/3/2024 8:39:35 AM
Sequence	C
Coil supply voltage	135.0 V DC
Time calculation	According to IEC 62271-100
Sample rate	10 kHz

Transducer settings

CB TN3, Channel 1	5.0 V - 1.9224 mil (digital)
-------------------	------------------------------

Main, resistive and auxiliary contacts

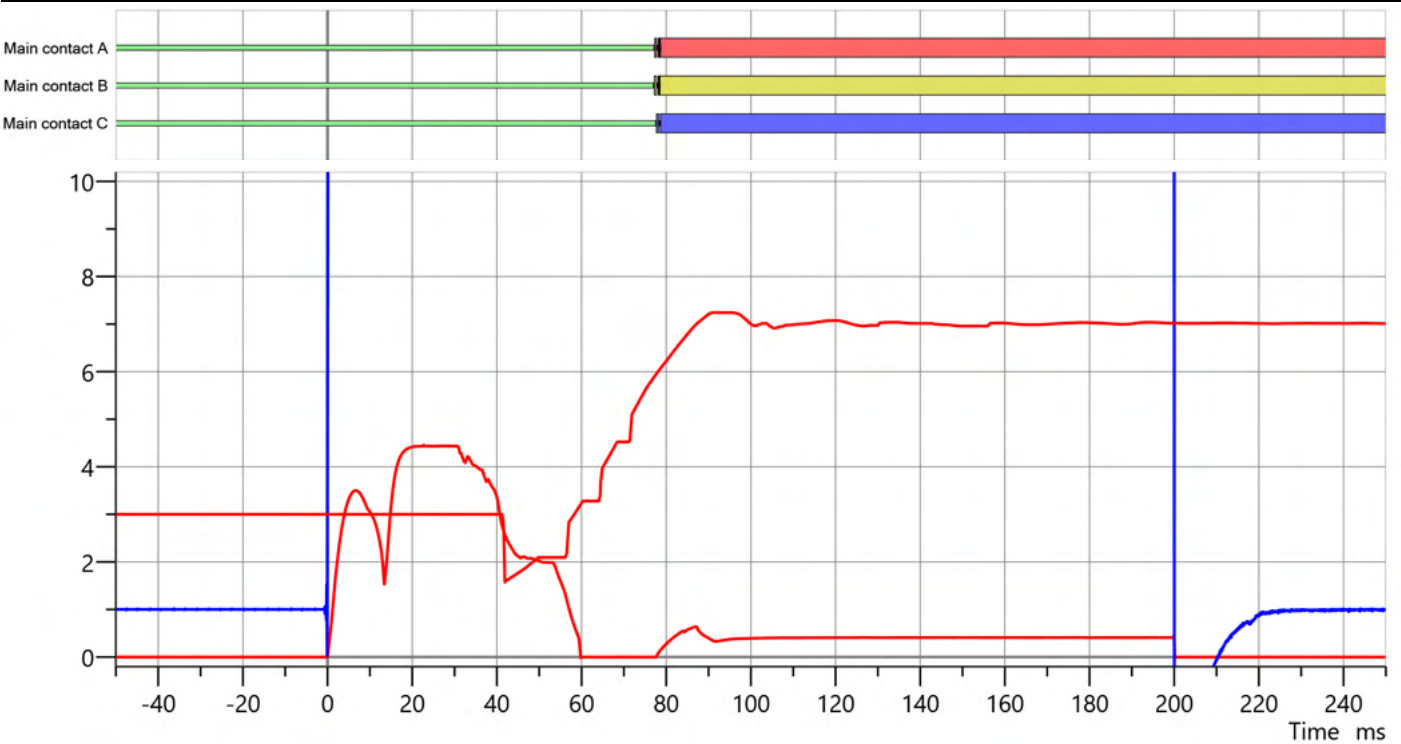

Label	Unit/div.	Y-Axis pos.	Label	Unit/div.	Y-Axis pos.		
Close coil (A)	■	1.00 A	0.00	Channel 1 (travel)	■	0.83 in	1.57
Close coil (V)	■	10.00 V	1.00				

Operating times

Meas.	Closing time (ms)	Closing sync. (ms)	Assessment
Breaker	77.60	0.50	Pass
A	77.20		Pass
Main contact A	77.20		Pass
B	77.10		Pass
Main contact B	77.10		Pass
C	77.60		Pass
Main contact C	77.60		Pass

Assessment Limits	t min	t max
Closing time	70.00 ms	90.00 ms
Closing sync. (contacts within a phase)	ms	ms
Closing sync. (between breaker phases)	ms	ms

Contact travel characteristics

Module	Channel	Total travel	Over-travel	Rebound	Damping dist. BLG	Damping time BLG	Assessment
CB TN3	Channel 1	3.31 in	0.19 in	0.03 in	in	ms	N. rated

Assessment Limits	d min	d max
Total travel, TT	in	in
Over-travel (Close), OT	in	in
Rebound (Close), RB	in	in
Contact wipe (Close), CW	in	in

Assessment Limits	Minimum	Maximum
Damping distance (Close)	in	in
Damping time (Close)	ms	ms

Main contact characteristics

Main contact	Travel data	Contact wipe	Reaction time	PIR close time	Bounce time	Bounce count	Assessment
Main contact A	Channel 1	0.92 in	58.60 ms	ms	1.30 ms	3	N. rated
Main contact B	No data		ms	ms	1.30 ms	2	N. rated
Main contact C	No data		ms	ms	0.90 ms	1	N. rated

Assessment Limits	Minimum	Maximum
Bounce time	ms	ms
Bounce count		
Reaction time	ms	ms

Coil characteristics

	Peak current (A)	Average current (A)	Average voltage (V)	Resistance (Ω)	Assessment
Close	4.46	3.29	132.53	40.34	N. rated

Assessment Limits	Minimum	Maximum
Peak close coil current	A	A
Peak trip coil current	A	A
Average close coil current	A	A
Average trip coil current	A	A
Average close coil voltage	V	V
Average trip coil voltage	V	V
Close coil resistance	Ω	Ω
Trip coil resistance	Ω	Ω

Comments

DLRO TESTS

A phase - 94.74 micro
B phase - 98.68 micro
C phase - 98.87 micro

MEGGER CLOSED TEST

A phase - 100.6 G
B phase - 128.2 G
C phase - 94.9 G

Test set information

Model	Serial number	Calibration date
CIBANO 500	JN863V	2024-05-28
CB TN3	KN628D	2024-06-03

O Timing

Execution date/Time	10/3/2024 8:40:28 AM
Sequence	O
Coil supply voltage	135.0 V DC
Time calculation	According to IEC 62271-100
Sample rate	10 kHz

Transducer settings

CB TN3, Channel 1	5.0 V - 1.9224 mil (digital)
-------------------	------------------------------

Main, resistive and auxiliary contacts

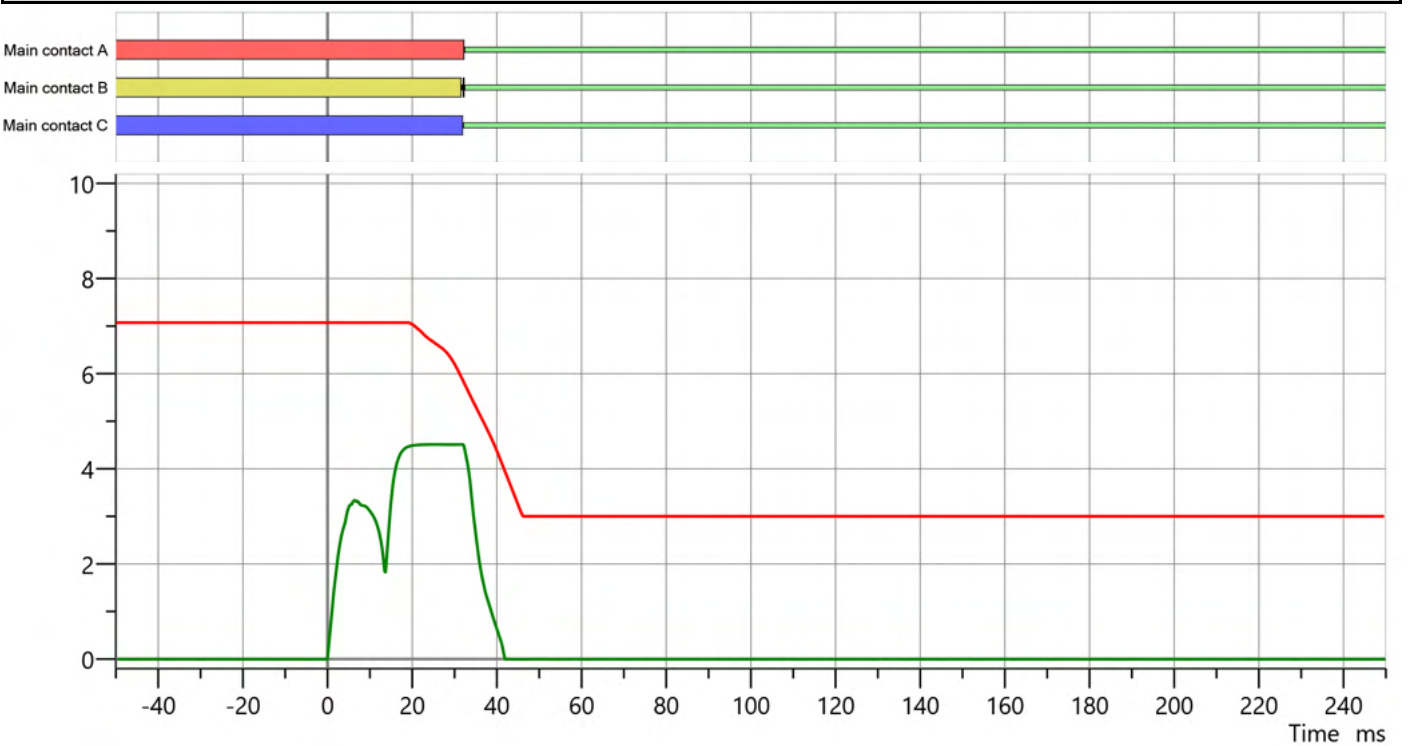

Label	Unit/div.	Y-Axis pos.	Label	Unit/div.	Y-Axis pos.		
Trip coil (A)	■	1.00 A	0.00	Channel 1 (travel)	■	0.87 in	3.00

Operating times

Meas.	Opening time (ms)	Opening sync. (ms)	Assessment
Breaker	32.30	0.30	Pass
A	32.30		Pass
Main contact A	32.30		Pass
B	32.30		Pass
Main contact B	32.30		Pass
C	32.00		Pass
Main contact C	32.00		Pass

Assessment Limits	t min	t max
Opening time	ms	32.00 ms
Opening sync. (contacts within a phase)	ms	ms
Opening sync. (between breaker phases)	ms	ms

Contact travel characteristics

Module	Channel	Total travel	Over-travel	Rebound	Damping distance	Assessment
CB TN3	Channel 1	3.53 in	0.00 in	0.00 in	in	N. rated

Assessment Limits	d min	d max
Total travel, TT	in	in
Over-travel (Trip), OT	in	in
Rebound (Trip), RB	in	in
Contact wipe (Trip), CW	in	in

Assessment Limits	Minimum	Maximum
Damping distance (Trip)	in	in

Main contact characteristics

Main contact	Travel data	Contact wipe	Reaction time	PIR close time	Bounce time	Bounce count	Assessment
Main contact A	Channel 1	1.11 in	20.20 ms	ms	0.00 ms	0	N. rated
Main contact B	No data		ms	ms	0.70 ms	1	N. rated
Main contact C	No data		ms	ms	0.00 ms	0	N. rated

Assessment Limits	Minimum	Maximum
Bounce time	ms	ms
Bounce count		
Reaction time	ms	ms

Coil characteristics

	Peak current (A)	Average current (A)	Average voltage (V)	Resistance (Ω)	Assessment
Trip A	4.51	3.57	132.45	37.14	N. rated

Assessment Limits	Minimum	Maximum
Peak close coil current	A	A
Peak trip coil current	A	A
Average close coil current	A	A
Average trip coil current	A	A
Average close coil voltage	V	V
Average trip coil voltage	V	V
Close coil resistance	Ω	Ω
Trip coil resistance	Ω	Ω

Comments

MEGGER OPEN TEST

A phase - 503.0 G

B phase - 515.0 G

C phase - 477.0 G

Test set information

Model	Serial number	Calibration date
CIBANO 500	JN863V	2024-05-28
CB TN3	KN628D	2024-06-03

CO Timing

Execution date/Time	10/3/2024 10:05:23 AM	
Sequence	CO	
Coil supply voltage	135.0 V DC	
Sample rate	10 kHz	

Transducer settings

CB TN3, Channel 1	5.0 V - 1.9224 mil (digital)
CB TN3, Channel 2	5.0 V - 0.0125 ° (digital)
CB TN3, Channel 3	5.0 V - 0.0125 ° (digital)

Main, resistive and auxiliary contacts

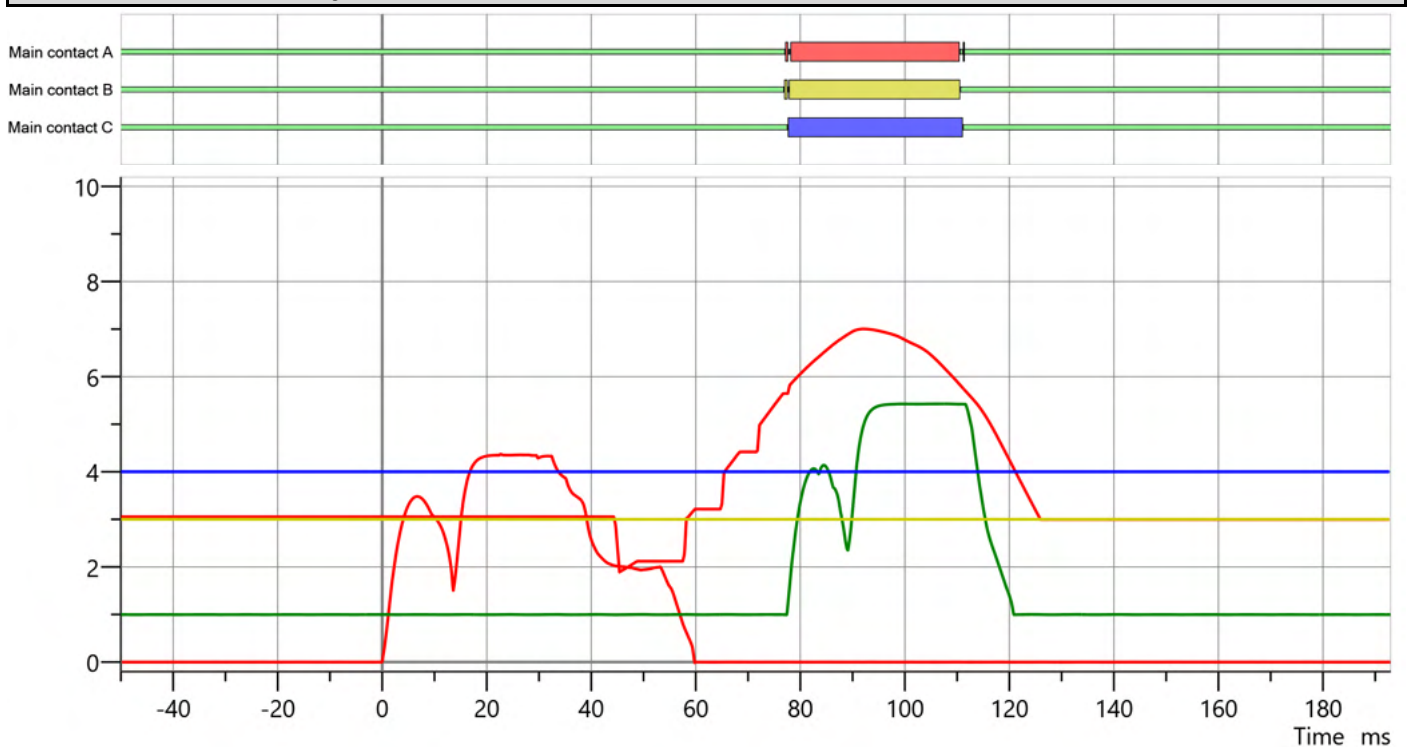

Label	Unit/div.	Y-Axis pos.	Label	Unit/div.	Y-Axis pos.
Close coil (A)	1.00 A	0.00	Channel 2 (travel)	1.00 °	3.00
Trip coil (A)	1.00 A	1.00	Channel 3 (travel)	1.00 °	4.00
Channel 1 (travel)	0.91 in	1.89			

Operating times

Meas.	Closing time (ms)	Closing sync. (ms)	Close-Open time 1 (ms)	Assessment
Breaker	77.60	0.70	34.40	Pass
A	77.10		34.20	Pass
Main contact A	77.10		34.20	Pass
B	76.90		33.70	Pass
Main contact B	76.90		33.70	Pass
C	77.60		33.50	Pass
Main contact C	77.60		33.50	Pass

Assessment Limits	t min	t max
Closing time	70.00 ms	90.00 ms
Closing sync. (contacts within a phase)	ms	ms
Closing sync. (between breaker phases)	ms	ms
Close-Open time	ms	ms

Coil characteristics

	Peak current (A)	Average current (A)	Average voltage (V)	Resistance (Ω)	Assessment
Close	4.37				N. rated
Trip A	4.43				N. rated

Assessment Limits	Minimum	Maximum
Peak close coil current	A	A
Peak trip coil current	A	A

Comments

Bushing - Energized Collar

Ambient temperature	24 °C	Weather	Clear
		Humidity	93 %

Comments

--

Standard test

No.	Meas.	Test mode	Freq.	V out	I out	Watt losses	Assessment
1	Bushing 1	UST-A	60.00 Hz	10.00 kV	0.05 mA	19.05 mW	Pass
2	Bushing 2	UST-A	60.00 Hz	10.00 kV	0.05 mA	32.18 mW	Pass
3	Bushing 3	UST-A	60.00 Hz	10.00 kV	0.05 mA	21.66 mW	Pass
4	Bushing 4	UST-A	60.00 Hz	10.00 kV	0.05 mA	25.68 mW	Pass
5	Bushing 5	UST-A	60.00 Hz	10.00 kV	0.05 mA	26.12 mW	Pass
6	Bushing 6	UST-A	60.00 Hz	10.00 kV	0.05 mA	33.17 mW	Pass

Circuit Breaker PF & CAP

Ambient temperature	24 °C	Weather	Clear
		Humidity	93 %

Comments

--

Standard test

Meas.	Position	Test mode	Freq.	V out	I out	Watt losses	PF meas	PF corr	Cap. meas	Assessment
C1G	Open	GST	60.00 Hz	10.00 kV	0.39 mA	45.22 mW	1.1459 %	1.1459 %	101.7 pF	Pass
C2G	Open	GST	60.00 Hz	10.00 kV	0.42 mA	29.35 mW	0.7030 %	0.7030 %	107.8 pF	Pass
C3G	Open	GST	60.00 Hz	10.00 kV	0.41 mA	37.15 mW	0.9127 %	0.9127 %	105.0 pF	Pass
C4G	Open	GST	60.00 Hz	10.00 kV	0.42 mA	27.77 mW	0.6590 %	0.6590 %	108.8 pF	Pass
C5G	Open	GST	60.00 Hz	10.00 kV	0.40 mA	34.71 mW	0.8773 %	0.8773 %	102.0 pF	Pass
C6G	Open	GST	60.00 Hz	10.00 kV	0.42 mA	22.87 mW	0.5505 %	0.5505 %	107.2 pF	Pass
C12	Open	UST-A	60.00 Hz	10.00 kV	0.00 mA	0.07 mW	0.2448 %	0.2448 %	0.8 pF	Pass
C34	Open	UST-A	60.00 Hz	10.00 kV	0.00 mA	0.05 mW	0.1937 %	0.1937 %	0.7 pF	Pass
C56	Open	UST-A	60.00 Hz	10.00 kV	0.00 mA	0.22 mW	0.7280 %	0.7280 %	0.8 pF	Pass

TESTING REPORTS FOR MV/LV BREAKERS



VACUUM CIRCUIT BREAKER TEST



CUSTOMER Orange Cogen PAGE _____
 ADDRESS 1901 S Clear Springs; Bartow FL 33830 DATE 10/2/2024
 OWNER Orange Cogen; 1901 S Clear Springs; Bartow FL 33830 JOB # 624942
 SITE Orange Cogen TEST STATUS _____ Pass
 SUBSTATION 15 kV Breakers ASSET ID 52STG Breaker
 EQUIPMENT 15 kV Breakers AMBIENT TEMPERATURE 80 °F HUMIDITY 67 %

MANUFACTURER Siemens SERIAL NUMBER 26855-001
 TYPE 15-GMI-1000-3000-77 MODEL NO. _____ DATE MANUFACTURED 2010
 MAXIMUM VOLTAGE 15 kV AMPACITY 3000 OPERATING VOLTAGE 13.8 kV
 INTERRUPTING CAPACITY 41 kA @ 95 kV TO _____ kV = _____ mVA

Description	INSPECTED	CONDITION	CLEAN/LUBE
OVERALL CLEANLINESS	<input checked="" type="checkbox"/>	Good	C/L
INSULATING MEMBERS	<input checked="" type="checkbox"/>	Good	C
MECHANICAL CONNECTIONS	<input checked="" type="checkbox"/>	Good	C
STRUCTURAL MEMBERS	<input checked="" type="checkbox"/>	Good	C
CUBICLE	<input checked="" type="checkbox"/>	Good	C/L
RACKING DEVICES	<input checked="" type="checkbox"/>	Good	
SHUTTER	<input checked="" type="checkbox"/>	Good	

Description	INSPECTED	CONDITION	CLEAN/LUBE
CONTACT FINGERS	<input checked="" type="checkbox"/>	Good	C/L
VACUUM BOTTLE	<input checked="" type="checkbox"/>	Good	C
CONTACT EROSION INDICATOR	<input checked="" type="checkbox"/>	Good	
OPERATING MECHANISM	<input checked="" type="checkbox"/>	Good	
CONTACT SEQUENCE	<input checked="" type="checkbox"/>	Good	
GROUND CONNECTION	<input checked="" type="checkbox"/>	Good	C
AUXILIARY DEVICES	<input checked="" type="checkbox"/>	Good	

INSULATION TEST VOLTAGE 5,000 kVDC EQUIPMENT TEMPERATURE 29 °C TEMPERATURE CORRECTION FACTOR TO 20°C, TCF 1.514
 MILLIWATT LOSS TEST VOLTAGE _____ kVAC HIGH POTENTIAL TEST VOLTAGE 27000 kVAC

INSULATION RESISTANCE	POLE 1 MEGOHMS (P1-P2)		POLE 2 MEGOHMS (P2-P3)		POLE 3 MEGOHMS (P1-P3)	
	READING	20°C	READING	20°C	READING	20°C
POLE TO POLE	1690000	2,558,660	2400000	3,633,600	1100000	1,665,400
POLE TO FRAME	1740000	2,634,360	5840000	8,841,760	8470000	1.282358e+007
LINE TO FRAME	6880000	1.041632e+007	3040000	4,602,560	2930000	4,436,020
LOAD TO FRAME	2450000	3,709,300	1980000	2,997,720	3080000	4,663,120
LINE TO LOAD	2870000	4,345,180	2990000	4,526,860	2670000	4,042,380

CONTROL WIRING - MEGOHMS			
READING		20°C	

CONTACT MEASUREMENTS		POLE 1	POLE 2	POLE 3
CONTACT TRAVEL - INCHES				
POLE RESISTANCE MICRO-OHMS	RDG.			
	20°C			
CONTACT RESISTANCE MICRO-OHMS	RDG.	12	11	12
	20°C	11.5901	10.6243	11.5901

	POLE 1	POLE 2	POLE 3
HIGH POTENTIAL TI kVAC	PASS	PASS	PASS
MILLIWATT LOSS kVAC	9.8	9.8	9.8
	POLE 1	POLE 2	POLE 3
OPENING SPEED (ft/sec)	33.3	33.75	33.75
CLOSING SPEED (ft/sec)	42.55	42.0	42.15

COUNTER READING: BEG. 2511
 END 2514

COMMENTS: _____
 DEFICIENCIES: _____

EQUIPMENT USED	#	Manufacturer	Model	Serial / ID Number	Type	Calibration Date	Calibration Due
	1	MEGGER	MIT1025	102435149	Other	1/1/2024	1/1/2025
	2	AEMC	6240	157278WHDV	Other	1/1/2024	1/1/2025
	3	HVI	HVA 60	GH0238.24C008	Other	1/1/2024	1/1/2025
	4	VANGUARD	DIGITMR S2	150074	Other	1/1/2024	1/1/2025

TESTED BY: Jason Watson



VACUUM CIRCUIT BREAKER TEST



CUSTOMER Orange Cogen PAGE _____
 ADDRESS 1901 S Clear Springs; Bartow FL 33830 DATE 10/2/2024
 OWNER Orange Cogen; 1901 S Clear Springs; Bartow FL 33830 JOB # 624942
 SITE Orange Cogen TEST STATUS _____ Pass
 SUBSTATION 15 kV Breakers ASSET ID 52GT1 Breaker
 EQUIPMENT 15 kV Breakers AMBIENT TEMPERATURE 80 °F HUMIDITY 67 %

MANUFACTURER Siemens SERIAL NUMBER 28995-00-001
 TYPE 15-GMI-1000-3000-77 MODEL NO. _____ DATE MANUFACTURED 2006
 MAXIMUM VOLTAGE 15 kV AMPACITY 3000 OPERATING VOLTAGE 13.8 kV
 INTERRUPTING CAPACITY 37 kA @ _____ kV TO _____ kV = _____ mVA

Description	INSPECTED	CONDITION	CLEAN/LUBE
OVERALL CLEANLINESS	<input checked="" type="checkbox"/>	Good	C/L
INSULATING MEMBERS	<input checked="" type="checkbox"/>	Good	C
MECHANICAL CONNECTIONS	<input checked="" type="checkbox"/>	Good	C
STRUCTURAL MEMBERS	<input checked="" type="checkbox"/>	Good	C
CUBICLE	<input checked="" type="checkbox"/>	Good	C/L
RACKING DEVICES	<input checked="" type="checkbox"/>	Good	
SHUTTER	<input checked="" type="checkbox"/>	Good	

Description	INSPECTED	CONDITION	CLEAN/LUBE
CONTACT FINGERS	<input checked="" type="checkbox"/>	Good	C/L
VACUUM BOTTLE	<input checked="" type="checkbox"/>	Good	C
CONTACT EROSION INDICATOR	<input checked="" type="checkbox"/>	Good	
OPERATING MECHANISM	<input checked="" type="checkbox"/>	Good	
CONTACT SEQUENCE	<input checked="" type="checkbox"/>	Good	
GROUND CONNECTION	<input checked="" type="checkbox"/>	Good	C
AUXILIARY DEVICES	<input checked="" type="checkbox"/>	Good	

INSULATION TEST VOLTAGE 5,000 kVDC EQUIPMENT TEMPERATURE 29 °C TEMPERATURE CORRECTION FACTOR TO 20°C, TCF 1.514

MILLIWATT LOSS TEST VOLTAGE _____ kVAC HIGH POTENTIAL TEST VOLTAGE 27000 kVAC

INSULATION RESISTANCE	POLE 1 MEGOHMS (P1-P2)		POLE 2 MEGOHMS (P2-P3)		POLE 3 MEGOHMS (P1-P3)	
	READING	20°C	READING	20°C	READING	20°C
POLE TO POLE	3930000	5,950,020	3710000	5,616,940	4190000	6,343,660
POLE TO FRAME	1902000	2,879,628	2040000	3,088,560	1852000	2,803,928
LINE TO FRAME	3750000	5,677,500	2160000	3,270,240	1339000	2,027,246
LOAD TO FRAME	1776000	2,688,864	1442000	2,183,188	1211000	1,833,454
LINE TO LOAD	3080000	4,663,120	847000	1,282,358	2830000	4,284,620

CONTROL WIRING - MEGOHMS			
READING		20°C	

	POLE 1	POLE 2	POLE 3
HIGH POTENTIAL TI kVAC	PASS	PASS	PASS
MILLIWATT LOSS kVAC	10	10	10

CONTACT MEASUREMENTS		POLE 1	POLE 2	POLE 3
CONTACT TRAVEL - INCHES				
POLE RESISTANCE MICRO-OHMS	RDG.			
	20°C			
CONTACT RESISTANCE MICRO-OHMS	RDG.	21	21	21
	20°C	20.2827	20.2827	20.2827

	POLE 1	POLE 2	POLE 3
OPENING SPEED (ft/sec)	36.05	36.45	36.10
CLOSING SPEED (ft/sec)	65.75	64.80	65.80

COUNTER READING: BEG. 03066
 END 03069

COMMENTS: _____
 DEFICIENCIES: _____

EQUIPMENT USED	#	Manufacturer	Model	Serial / ID Number	Type	Calibration Date	Calibration Due
	1	MEGGER	MIT1025	102435149	Other	1/1/2024	1/1/2025
	2	AEMC	6240	157278WHDV	Other	1/1/2024	1/1/2025
	3	HVI	HVA 60	GH0238.24C008	Other	1/1/2024	1/1/2025
	4	VANGUARD	DIGITMR S2	150074	Other	1/1/2024	1/1/2025

TESTED BY: Matthew Falchetti / Andrew Kirk



VACUUM CIRCUIT BREAKER TEST



CUSTOMER Orange Cogen PAGE _____
 ADDRESS 1901 S Clear Springs; Bartow FL 33830 DATE 10/2/2024
 OWNER Orange Cogen; 1901 S Clear Springs; Bartow FL 33830 JOB # 624942
 SITE Orange Cogen TEST STATUS _____ Pass
 SUBSTATION 15 kV Breakers ASSET ID 52GT2 Breaker
 EQUIPMENT 15 kV Breakers AMBIENT TEMPERATURE 80 °F HUMIDITY 67 %

MANUFACTURER Siemens SERIAL NUMBER R-3006127035-100-001
 TYPE 15-GMI-1000-3000-77 MODEL NO. _____ DATE MANUFACTURED 2016
 MAXIMUM VOLTAGE 15 kV AMPACITY 3000 OPERATING VOLTAGE 13.8 kV
 INTERRUPTING CAPACITY 41 kA @ 95 kV TO _____ kV = _____ mVA

Description	INSPECTED	CONDITION	CLEAN/LUBE
OVERALL CLEANLINESS	<input checked="" type="checkbox"/>	Good	C/L
INSULATING MEMBERS	<input checked="" type="checkbox"/>	Good	C
MECHANICAL CONNECTIONS	<input checked="" type="checkbox"/>	Good	C
STRUCTURAL MEMBERS	<input checked="" type="checkbox"/>	Good	C
CUBICLE	<input checked="" type="checkbox"/>	Good	C/L
RACKING DEVICES	<input checked="" type="checkbox"/>	Good	
SHUTTER	<input checked="" type="checkbox"/>	Good	

Description	INSPECTED	CONDITION	CLEAN/LUBE
CONTACT FINGERS	<input checked="" type="checkbox"/>	Good	C/L
VACUUM BOTTLE	<input checked="" type="checkbox"/>	Good	C
CONTACT EROSION INDICATOR	<input checked="" type="checkbox"/>	Good	
OPERATING MECHANISM	<input checked="" type="checkbox"/>	Good	
CONTACT SEQUENCE	<input checked="" type="checkbox"/>	Good	
GROUND CONNECTION	<input checked="" type="checkbox"/>	Good	C
AUXILIARY DEVICES	<input checked="" type="checkbox"/>	Good	

INSULATION TEST VOLTAGE 5,000 kVDC EQUIPMENT TEMPERATURE 29 °C TEMPERATURE CORRECTION FACTOR TO 20°C, TCF 1.514
 MILLIWATT LOSS TEST VOLTAGE _____ kVAC HIGH POTENTIAL TEST VOLTAGE 27000 kVAC

INSULATION RESISTANCE	POLE 1 MEGOHMS (P1-P2)		POLE 2 MEGOHMS (P2-P3)		POLE 3 MEGOHMS (P1-P3)	
	READING	20°C	READING	20°C	READING	20°C
POLE TO POLE	1010000	1,529,140	1210000	1,831,940	1260000	1,907,640
POLE TO FRAME	709000	1,073,426	6658000	1.008021e+007	6900000	1.04466e+007
LINE TO FRAME	8846000	1.339284e+007	6206000	9,395,884	1280000	1,937,920
LOAD TO FRAME	1490000	2,255,860	1820000	2,755,480	1370000	2,074,180
LINE TO LOAD	2900000	4,390,600	2060000	3,118,840	2210000	3,345,940

CONTROL WIRING - MEGOHMS			
READING		20°C	

	POLE 1	POLE 2	POLE 3
HIGH POTENTIAL TI kVAC	PASS	PASS	PASS
MILLIWATT LOSS kVAC	9.6	9.6	9.6

CONTACT MEASUREMENTS		POLE 1	POLE 2	POLE 3
CONTACT TRAVEL - INCHES				
POLE RESISTANCE MICRO-OHMS	RDG.			
	20°C			
CONTACT RESISTANCE MICRO-OHMS	RDG.	22	20	22
	20°C	21.2486	19.3169	21.2486

	POLE 1	POLE 2	POLE 3
OPENING SPEED (ft/sec)	35.80	35.90	35.85
CLOSING SPEED (ft/sec)	38.70	38.45	38.45

COUNTER READING: BEG. _____
 END _____

COMMENTS: _____
 DEFICIENCIES: _____

EQUIPMENT USE#	#	Manufacturer	Model	Serial / ID Number	Type	Calibration Date	Calibration Due
	1	MEGGER	MIT1025	102435149	Other	1/1/2024	1/1/2025
	2	AEMC	6240	157278WHDV	Other	1/1/2024	1/1/2025
	3	HVI	HVA 60	GH0238.24C008	Other	1/1/2024	1/1/2025
	4	VANGUARD	DIGITMR S2	150074	Other	1/1/2024	1/1/2025

TESTED BY: Jason Watson



LOW VOLTAGE POWER CIRCUIT BREAKER TEST



CUSTOMER Orange Cogen PAGE _____
 ADDRESS 1901 S Clear Springs; Bartow FL 33830 DATE 9/26/2024
 OWNER Orange Cogen; 1901 S Clear Springs; Bartow FL 33830 JOB # 624942
 SITE Orange Cogen TEST STATUS Pass
 SUBSTATION 480 Switchgear ASSET ID Main Breaker 216E300 - 4000 Amps
 EQUIPMENT 480 Breakers AMBIENT TEMPERATURE 70 °F HUMIDITY 56 %

MANUFACTURER Siemens SN / SO NO. R-71809A-1 FRAME SIZE(F) 4000
 BREAKER TYPE RL-4000 SENSOR TAPS _____ MOUNTING B.I. D.O.
 FUSE CAT. NO. _____ CUBICLE CODE _____ THERMAL MEMORY ON OFF
 TRIP UNIT TYPE Static Trip III CATALOG NO. _____ ZONE INTLK TARGETS

Description	INSPECTED	CONDITION	CLEAN/LUBE
CUBICLE AND RACKING DEVICES	<input checked="" type="checkbox"/>	Good	
CONTACT FINGERS	<input checked="" type="checkbox"/>	Good	
LOADING AND ARCING CONTACTS	<input checked="" type="checkbox"/>	Good	
OVERCURRENT DEV. BATTERY	<input type="checkbox"/>		

Description	INSPECTED	CONDITION	CLEAN/LUBE
ARC CHUTES	<input checked="" type="checkbox"/>	Good	
AUXILIARY DEVICES	<input checked="" type="checkbox"/>	Good	
GROUND CONNECTION	<input checked="" type="checkbox"/>	Good	
LOAD CONDUCTOR NO. <u>0</u> Size <u>CU</u> <input type="radio"/> <u>AL</u> <input type="radio"/>			

SETTINGS AS FOUND LONG TIME PU .8 X _____ A = _____ A DELAY 3.5
 RATING PLUG(R) 4000 SHORT TIME PU 3 = _____ A DELAY .08 IPT IN OUT N/A
 SENSOR TAP _____ INST. PU _____ A ON OFF
 GRD. FLT. 3W 4W GRD. FLT. PU 20 = _____ A ON OFF DELAY 10 IPT IN OUT N/A

SETTINGS AS LEFT LONG TIME PU .8 X _____ A = _____ A DELAY 3.5
 RATING PLUG(R) 4000 SHORT TIME PU 3 = _____ A DELAY .08 IPT IN OUT N/A
 SENSOR TAP _____ INST. PU _____ A ON OFF
 GRD. FLT. 3W 4W GRD. FLT. PU 20 = _____ A ON OFF DELAY 10 IPT IN OUT N/A

FUNCTION	TEST AMPERES	CURRENT MULTIPLE	TIME BAND		POLE 1		POLE 2		POLE 3	
			MINIMUM	MAXIMUM	AS FOUND (seconds)	AS LEFT (seconds)	AS FOUND (seconds)	AS LEFT (seconds)	AS FOUND (seconds)	AS LEFT (seconds)
INSTANTANEOUS										
	IPU									
SHORT TIME	1.000					0.130		0.130		0.130
	STPU									
LONG TIME	1.500					0.139		0.139		0.139
	LTPU									
	VOLTAGE DROP @ LONG TIME TEST CURRENT									
GROUND FAULT	.500					0.419		0.419		0.419
	GFPU									

EQUIPMENT TEMPERATURE 22 °C TEMPERATURE CORRECTION FACTOR TO 20°C, TCF 1.1

INSULATION RESISTANCE	POLE 1 MΩ (P1-P2)		POLE 2 MΩ (P2-P3)		POLE 3 MΩ (P3-P4)	
	READING	20°C	READING	20°C	READING	20°C
POLE TO POLE	2e+006	2,200,000	2e+007	2.2e+007	2e+006	2,200,000
POLE TO FRAME	2e+006	2,200,000	2e+007	2.2e+007	2e+006	2,200,000
LINE TO LOAD	2e+006	2,200,000	2e+007	2.2e+007	2e+006	2,200,000

POLE RESISTANCE - MICRO-OHMS		
READING		
POLE 1	POLE 2	POLE 3
11	10	11

CONTROL WIRING			COUNTER READING BEG/END	
READING	20°C		N/A	N/A

TESTED BY: Matthew Falchetti / Andrew Kirk / Jason Watson



LOW VOLTAGE POWER CIRCUIT BREAKER TEST



PAGE _____

COMMENTS:

DEFICIENCIES:

Empty text boxes for comments and deficiencies.

EQUIPMENT USED

#	Manufacturer	Model	Serial / ID Number	Type	Calibration Date	Calibration Due
1	SIEMENS	Static Trip III Set	190021	Other	1/1/2024	1/1/2025
2	MEGGER	MIT1025	102435149	Other	1/1/2024	1/1/2025
3	AEMC	6240	157278WHDV	Other	1/1/2024	1/1/2025



LOW VOLTAGE POWER CIRCUIT BREAKER TEST



CUSTOMER Orange Cogen PAGE _____
 ADDRESS 1901 S Clear Springs; Bartow FL 33830 DATE 10/5/2024
 OWNER Orange Cogen; 1901 S Clear Springs; Bartow FL 33830 JOB # 624942
 SITE Orange Cogen TEST STATUS _____ Pass
 SUBSTATION 480 Switchgear ASSET ID _____ 480V MCC-1
 EQUIPMENT 480 Breakers AMBIENT TEMPERATURE 70 °F HUMIDITY 56 %

MANUFACTURER Siemens SN / SO NO. R-71810A-2 FRAME SIZE(F) 2000
 BREAKER TYPE RL-2000 SENSOR TAPS _____ MOUNTING B.I. D.O.
 FUSE CAT. NO. _____ CUBICLE CODE _____ THERMAL MEMORY ON OFF
 TRIP UNIT TYPE Static Trip III CATALOG NO. _____ ZONE INTLK TARGETS

Description	INSPECTED	CONDITION	CLEAN/LUBE
CUBICLE AND RACKING DEVICES	<input checked="" type="checkbox"/>	Good	
CONTACT FINGERS	<input checked="" type="checkbox"/>	Good	
LOADING AND ARCING CONTACTS	<input checked="" type="checkbox"/>	Good	
OVERCURRENT DEV. BATTERY	<input type="checkbox"/>		

Description	INSPECTED	CONDITION	CLEAN/LUBE
ARC CHUTES	<input checked="" type="checkbox"/>	Good	
AUXILIARY DEVICES	<input checked="" type="checkbox"/>	Good	
GROUND CONNECTION	<input checked="" type="checkbox"/>	Good	
LOAD CONDUCTOR NO. <u>0</u> Size <u>CU</u> <input type="radio"/> <u>AL</u> <input type="radio"/>			

SETTINGS AS FOUND LONG TIME PU 9.5 X _____ A = _____ A DELAY 3.5
 RATING PLUG(R) 2000 SHORT TIME PU 3 = _____ A DELAY .08 I²T IN OUT N/A
 SENSOR TAP _____ INST. PU _____ A ON OFF
 GRD. FLT. 3W 4W GRD. FLT. PU 20 = _____ A ON OFF DELAY 10 I²T IN OUT N/A

SETTINGS AS LEFT LONG TIME PU 9.5 X _____ A = _____ A DELAY 3.5
 RATING PLUG(R) 2000 SHORT TIME PU 3 = _____ A DELAY .08 I²T IN OUT N/A
 SENSOR TAP _____ INST. PU _____ A ON OFF
 GRD. FLT. 3W 4W GRD. FLT. PU 20 = _____ A ON OFF DELAY 10 I²T IN OUT N/A

FUNCTION	TEST AMPERES	CURRENT MULTIPLE	TIME BAND		POLE 1		POLE 2		POLE 3	
			MINIMUM	MAXIMUM	AS FOUND (seconds)	AS LEFT (seconds)	AS FOUND (seconds)	AS LEFT (seconds)	AS FOUND (seconds)	AS LEFT (seconds)
			INSTANTANEOUS		IPU					
SHORT TIME		<u>0.580</u>				<u>18.382</u>		<u>18.382</u>		<u>18.382</u>
		STPU								
LONG TIME		<u>0.765</u>				<u>17.509</u>		<u>17.509</u>		<u>17.509</u>
		LTPU								
		VOLTAGE DROP @ LONG TIME TEST CURRENT								
GROUND FAULT		<u>.500</u>				<u>0.442</u>		<u>0.442</u>		<u>0.442</u>
		GFPU								

EQUIPMENT TEMPERATURE 22 °C TEMPERATURE CORRECTION FACTOR TO 20°C, TCF 1.1

INSULATION RESISTANCE	POLE 1 MΩ (P1-P2)		POLE 2 MΩ (P2-P3)		POLE 3 MΩ (P3-P4)	
	READING	20°C	READING	20°C	READING	20°C
POLE TO POLE	<u>2e+006</u>	<u>2,200,000</u>	<u>2e+006</u>	<u>2,200,000</u>	<u>2e+006</u>	<u>2,200,000</u>
POLE TO FRAME	<u>1.28e+006</u>	<u>1,408,000</u>	<u>2e+006</u>	<u>2,200,000</u>	<u>1.63e+006</u>	<u>1,793,000</u>
LINE TO LOAD	<u>2e+006</u>	<u>2,200,000</u>	<u>1.16e+006</u>	<u>1,276,000</u>	<u>2e+006</u>	<u>2,200,000</u>
CONTROL WIRING				COUNTER READING BEG/END		
READING				N/A		

POLE RESISTANCE - MICRO-OHMS		
READING		
POLE 1	POLE 2	POLE 3
<u>18</u>	<u>19</u>	<u>18</u>

TESTED BY: Matthew Falchetti / Andrew Kirk / Jason Watson



LOW VOLTAGE POWER CIRCUIT BREAKER TEST



PAGE _____

COMMENTS:

DEFICIENCIES:

Empty text boxes for comments and deficiencies.

EQUIPMENT USED

#	Manufacturer	Model	Serial / ID Number	Type	Calibration Date	Calibration Due
1	SIEMENS	Static Trip III Set	190021	Other	1/1/2024	1/1/2025
2	MEGGER	MIT1025	102435149	Other	1/1/2024	1/1/2025
3	AEMC	6240	157278WHDV	Other	1/1/2024	1/1/2025



LOW VOLTAGE POWER CIRCUIT BREAKER TEST



CUSTOMER Orange Cogen PAGE _____
 ADDRESS 1901 S Clear Springs; Bartow FL 33830 DATE 10/5/2024
 OWNER Orange Cogen; 1901 S Clear Springs; Bartow FL 33830 JOB # 624942
 SITE Orange Cogen TEST STATUS _____ Pass
 SUBSTATION 480 Switchgear ASSET ID Main Breaker 116E300 - 4000 Amps
 EQUIPMENT 480 Breakers AMBIENT TEMPERATURE 70 °F HUMIDITY 56 %

MANUFACTURER Siemens SN / SO NO. R-71809A-3 FRAME SIZE(F) 4000
 BREAKER TYPE RL-4000 SENSOR TAPS _____ MOUNTING B.I. D.O.
 FUSE CAT. NO. _____ CUBICLE CODE _____ THERMAL MEMORY ON OFF
 TRIP UNIT TYPE Static Trip III CATALOG NO. _____ ZONE INTLK TARGETS

Description	INSPECTED	CONDITION	CLEAN/LUBE
CUBICLE AND RACKING DEVICES	<input checked="" type="checkbox"/>	Good	
CONTACT FINGERS	<input checked="" type="checkbox"/>	Good	
LOADING AND ARCING CONTACTS	<input checked="" type="checkbox"/>	Good	
OVERCURRENT DEV. BATTERY	<input type="checkbox"/>		

Description	INSPECTED	CONDITION	CLEAN/LUBE
ARC CHUTES	<input checked="" type="checkbox"/>	Good	
AUXILIARY DEVICES	<input checked="" type="checkbox"/>	Good	
GROUND CONNECTION	<input checked="" type="checkbox"/>	Good	
LOAD CONDUCTOR NO. <u>0</u> Size <u>CU</u> <input type="radio"/> <u>AL</u> <input type="radio"/>			

SETTINGS AS FOUND LONG TIME PU .8 X _____ A = _____ A DELAY 3.5
 RATING PLUG(R) 4000 SHORT TIME PU 3 = _____ A DELAY .08 IPT IN OUT N/A
 SENSOR TAP _____ INST. PU _____ A ON OFF
 GRD. FLT. 3W 4W GRD. FLT. PU 20 = _____ A ON OFF DELAY 10 IPT IN OUT N/A

SETTINGS AS LEFT LONG TIME PU .8 X _____ A = _____ A DELAY 3.5
 RATING PLUG(R) 4000 SHORT TIME PU 3 = _____ A DELAY .08 IPT IN OUT N/A
 SENSOR TAP _____ INST. PU _____ A ON OFF
 GRD. FLT. 3W 4W GRD. FLT. PU 20 = _____ A ON OFF DELAY 10 IPT IN OUT N/A

FUNCTION	TEST AMPERES	CURRENT MULTIPLE	TIME BAND		POLE 1		POLE 2		POLE 3	
			MINIMUM	MAXIMUM	AS FOUND (seconds)	AS LEFT (seconds)	AS FOUND (seconds)	AS LEFT (seconds)	AS FOUND (seconds)	AS LEFT (seconds)
INSTANTANEOUS										
		IPU								
SHORT TIME	<u>0.580</u>					<u>0.680</u>		<u>0.680</u>		<u>0.680</u>
		STPU								
LONG TIME	<u>0.750</u>					<u>16.580</u>		<u>16.580</u>		<u>16.580</u>
		LTPU								
	VOLTAGE DROP @ LONG TIME TEST CURRENT									
GROUND FAULT	<u>.500</u>					<u>0.420</u>		<u>0.420</u>		<u>0.420</u>
		GFPU								

EQUIPMENT TEMPERATURE 22 °C TEMPERATURE CORRECTION FACTOR TO 20°C, TCF 1.1

INSULATION RESISTANCE	POLE 1 MΩ (P1-P2)		POLE 2 MΩ (P2-P3)		POLE 3 MΩ (P3-P4)	
	READING	20°C	READING	20°C	READING	20°C
POLE TO POLE	<u>2e+006</u>	<u>2,200,000</u>	<u>2e+006</u>	<u>2,200,000</u>	<u>2e+006</u>	<u>2,200,000</u>
POLE TO FRAME	<u>777,000</u>	<u>854,700.0</u>	<u>914,000</u>	<u>1,005,400</u>	<u>940,000</u>	<u>1,034,000</u>
LINE TO LOAD	<u>2e+006</u>	<u>2,200,000</u>	<u>2e+006</u>	<u>2,200,000</u>	<u>2e+006</u>	<u>2,200,000</u>
CONTROL WIRING				COUNTER READING BEG/END		
READING		20°C		N/A	N/A	

POLE RESISTANCE - MICRO-OHMS		
READING		
POLE 1	POLE 2	POLE 3
<u>13</u>	<u>12</u>	<u>12</u>

TESTED BY: Matthew Falchetti / Andrew Kirk / Jason Watson



LOW VOLTAGE POWER CIRCUIT BREAKER TEST



PAGE _____

COMMENTS:

DEFICIENCIES:

Empty text boxes for comments and deficiencies.

EQUIPMENT USED

#	Manufacturer	Model	Serial / ID Number	Type	Calibration Date	Calibration Due
1	SIEMENS	Static Trip III Set	190021	Other	1/1/2024	1/1/2025
2	MEGGER	MIT1025	102435149	Other	1/1/2024	1/1/2025
3	AEMC	6240	157278WHDV	Other	1/1/2024	1/1/2025



LOW VOLTAGE POWER CIRCUIT BREAKER TEST



CUSTOMER Orange Cogen PAGE _____
 ADDRESS 1901 S Clear Springs; Bartow FL 33830 DATE 10/5/2024
 OWNER Orange Cogen; 1901 S Clear Springs; Bartow FL 33830 JOB # 624942
 SITE Orange Cogen TEST STATUS _____ Pass
 SUBSTATION 480 Switchgear ASSET ID _____ 480V MCC-3
 EQUIPMENT 480 Breakers AMBIENT TEMPERATURE 70 °F HUMIDITY 56 %

MANUFACTURER Siemens SN / SO NO. R-71811C-1 FRAME SIZE(F) 1600
 BREAKER TYPE RL-1600 SENSOR TAPS _____ MOUNTING B.I. D.O.
 FUSE CAT. NO. _____ CUBICLE CODE _____ THERMAL MEMORY ON OFF
 TRIP UNIT TYPE Static Trip III CATALOG NO. _____ ZONE INTLK TARGETS

Description	INSPECTED	CONDITION	CLEAN/LUBE
CUBICLE AND RACKING DEVICES	<input checked="" type="checkbox"/>	Good	
CONTACT FINGERS	<input checked="" type="checkbox"/>	Good	
LOADING AND ARCING CONTACTS	<input checked="" type="checkbox"/>	Good	
OVERCURRENT DEV. BATTERY	<input type="checkbox"/>		

Description	INSPECTED	CONDITION	CLEAN/LUBE
ARC CHUTES	<input checked="" type="checkbox"/>	Good	
AUXILIARY DEVICES	<input checked="" type="checkbox"/>	Good	
GROUND CONNECTION	<input checked="" type="checkbox"/>	Good	
LOAD CONDUCTOR NO. <u>0</u> Size <u>CU</u> <input type="radio"/> <u>AL</u> <input type="radio"/>			

SETTINGS AS FOUND LONG TIME PU 9.0 X _____ A = _____ A DELAY 3.5
 RATING PLUG(R) 2000 SHORT TIME PU 2 = _____ A DELAY .08 IPT IN OUT N/A
 SENSOR TAP _____ INST. PU = _____ A ON OFF
 GRD. FLT. 3W 4W GRD. FLT. PU 20 = _____ A ON OFF DELAY 10 IPT IN OUT N/A

SETTINGS AS LEFT LONG TIME PU 9.0 X _____ A = _____ A DELAY 3.5
 RATING PLUG(R) 2000 SHORT TIME PU 2 = _____ A DELAY .08 IPT IN OUT N/A
 SENSOR TAP _____ INST. PU = _____ A ON OFF
 GRD. FLT. 3W 4W GRD. FLT. PU 20 = _____ A ON OFF DELAY 10 IPT IN OUT N/A

FUNCTION	TEST AMPERES	CURRENT MULTIPLE	TIME BAND		POLE 1		POLE 2		POLE 3	
			MINIMUM	MAXIMUM	AS FOUND (seconds)	AS LEFT (seconds)	AS FOUND (seconds)	AS LEFT (seconds)	AS FOUND (seconds)	AS LEFT (seconds)
			INSTANTANEOUS		IPU					
SHORT TIME		<u>0.580</u>				<u>18.382</u>		<u>18.382</u>		<u>18.382</u>
		STPU								
LONG TIME		<u>0.765</u>				<u>17.509</u>		<u>17.509</u>		<u>17.509</u>
		LTPU								
		VOLTAGE DROP @ LONG TIME TEST CURRENT								
GROUND FAULT		<u>.500</u>				<u>0.442</u>		<u>0.442</u>		<u>0.442</u>
		GFPU								

EQUIPMENT TEMPERATURE 22 °C TEMPERATURE CORRECTION FACTOR TO 20°C, TCF 1.1

INSULATION RESISTANCE	POLE 1 MΩ (P1-P2)		POLE 2 MΩ (P2-P3)		POLE 3 MΩ (P3-P4)	
	READING	20°C	READING	20°C	READING	20°C
POLE TO POLE	<u>2e+006</u>	<u>2,200,000</u>	<u>2e+006</u>	<u>2,200,000</u>	<u>2e+006</u>	<u>2,200,000</u>
POLE TO FRAME	<u>2e+006</u>	<u>2,200,000</u>	<u>2e+006</u>	<u>2,200,000</u>	<u>2e+006</u>	<u>2,200,000</u>
LINE TO LOAD	<u>2e+006</u>	<u>2,200,000</u>	<u>2e+006</u>	<u>2,200,000</u>	<u>2e+006</u>	<u>2,200,000</u>

POLE RESISTANCE - MICRO-OHMS		
READING		
POLE 1	POLE 2	POLE 3
<u>19</u>	<u>19</u>	<u>19</u>

CONTROL WIRING				COUNTER READING BEG/END	
READING	20°C			N/A	N/A

TESTED BY: Matthew Falchetti / Andrew Kirk / Jason Watson



LOW VOLTAGE POWER CIRCUIT BREAKER TEST



PAGE _____

COMMENTS:

DEFICIENCIES:

Empty text boxes for comments and deficiencies.

EQUIPMENT USED

#	Manufacturer	Model	Serial / ID Number	Type	Calibration Date	Calibration Due
1	SIEMENS	Static Trip III Set	190021	Other	1/1/2024	1/1/2025
2	MEGGER	MIT1025	102435149	Other	1/1/2024	1/1/2025
3	AEMC	6240	157278WHDV	Other	1/1/2024	1/1/2025



LOW VOLTAGE POWER CIRCUIT BREAKER TEST



CUSTOMER Orange Cogen PAGE _____
 ADDRESS 1901 S Clear Springs; Bartow FL 33830 DATE 9/24/2024
 OWNER Orange Cogen; 1901 S Clear Springs; Bartow FL 33830 JOB # 624942
 SITE Orange Cogen TEST STATUS _____ Pass
 SUBSTATION 480 Switchgear ASSET ID Tie Breaker 4000 Amps
 EQUIPMENT 480 Breakers AMBIENT TEMPERATURE 70 °F HUMIDITY 56 %

MANUFACTURER Siemens SN / SO NO. R-71809A-2 FRAME SIZE(F) 4000
 BREAKER TYPE RL-4000 SENSOR TAPS _____ MOUNTING B.I. D.O.
 FUSE CAT. NO. _____ CUBICLE CODE _____ THERMAL MEMORY ON OFF
 TRIP UNIT TYPE Static Trip III CATALOG NO. _____ ZONE INTLK TARGETS

Description	INSPECTED	CONDITION	CLEAN/LUBE
CUBICLE AND RACKING DEVICES	<input checked="" type="checkbox"/>	Good	
CONTACT FINGERS	<input checked="" type="checkbox"/>	Good	
LOADING AND ARCING CONTACTS	<input checked="" type="checkbox"/>	Good	
OVERCURRENT DEV. BATTERY	<input type="checkbox"/>		

Description	INSPECTED	CONDITION	CLEAN/LUBE
ARC CHUTES	<input checked="" type="checkbox"/>	Good	
AUXILIARY DEVICES	<input checked="" type="checkbox"/>	Good	
GROUND CONNECTION	<input checked="" type="checkbox"/>	Good	
LOAD CONDUCTOR NO. <u>0</u> Size <u>CU</u> <input checked="" type="radio"/> <u>AL</u> <input type="radio"/>			

SETTINGS AS FOUND LONG TIME PU .8 X _____ A = _____ A DELAY 3.5
 RATING PLUG(R) 4000 SHORT TIME PU 3 = _____ A DELAY .08 IPT IN OUT N/A
 SENSOR TAP _____ INST. PU _____ A ON OFF
 GRD. FLT. 3W 4W GRD. FLT. PU 20 = _____ A ON OFF DELAY 10 IPT IN OUT N/A

SETTINGS AS LEFT LONG TIME PU .8 X _____ A = _____ A DELAY 3.5
 RATING PLUG(R) 4000 SHORT TIME PU 3 = _____ A DELAY .08 IPT IN OUT N/A
 SENSOR TAP _____ INST. PU _____ A ON OFF
 GRD. FLT. 3W 4W GRD. FLT. PU 20 = _____ A ON OFF DELAY 10 IPT IN OUT N/A

FUNCTION	TEST AMPERES	CURRENT MULTIPLE	TIME BAND		POLE 1		POLE 2		POLE 3	
			MINIMUM	MAXIMUM	AS FOUND (seconds)	AS LEFT (seconds)	AS FOUND (seconds)	AS LEFT (seconds)	AS FOUND (seconds)	AS LEFT (seconds)
			INSTANTANEOUS		IPU					
SHORT TIME		1.000				0.130		0.130		0.130
		STPU								
LONG TIME		1.500				0.139		0.139		0.139
		LTPU								
		VOLTAGE DROP @ LONG TIME TEST CURRENT								
GROUND FAULT		.500				0.419		0.419		0.419
		GFPU								

EQUIPMENT TEMPERATURE 22 °C TEMPERATURE CORRECTION FACTOR TO 20°C, TCF 1.1

INSULATION RESISTANCE	POLE 1 MΩ (P1-P2)		POLE 2 MΩ (P2-P3)		POLE 3 MΩ (P3-P4)	
	READING	20°C	READING	20°C	READING	20°C
POLE TO POLE	1.35	1.49	1.46	1.61	1.76	1.94
POLE TO FRAME	1.39	1.53	1.44	1.58	1.37	1.51
LINE TO LOAD	2	2.20	2	2.20	2	2.20
CONTROL WIRING				COUNTER READING BEG/END		
READING				20°C		
				N/A		

POLE RESISTANCE - MICRO-OHMS		
READING		
POLE 1	POLE 2	POLE 3
15	14	14

TESTED BY: Matthew Falchetti / Andrew Kirk / Jason Watson



LOW VOLTAGE POWER CIRCUIT BREAKER TEST



PAGE _____

COMMENTS:

DEFICIENCIES:

EQUIPMENT USED:

#	Manufacturer	Model	Serial / ID Number	Type	Calibration Date	Calibration Due
1	SIEMENS	Static Trip III Set	190021	Other	1/1/2024	1/1/2025
2	MEGGER	MIT1025	102435149	Other	1/1/2024	1/1/2025
3	AEMC	6240	157278WHDV	Other	1/1/2024	1/1/2025



LOW VOLTAGE POWER CIRCUIT BREAKER TEST



CUSTOMER Orange Cogen PAGE _____
 ADDRESS 1901 S Clear Springs; Bartow FL 33830 DATE 10/5/2024
 OWNER Orange Cogen; 1901 S Clear Springs; Bartow FL 33830 JOB # 624942
 SITE Orange Cogen TEST STATUS _____ Pass
 SUBSTATION 480 Switchgear ASSET ID _____ Spare 1600A
 EQUIPMENT 480 Breakers AMBIENT TEMPERATURE 70 °F HUMIDITY 56 %

MANUFACTURER Siemens SN / SO NO. R-71810A-2 FRAME SIZE(F) 2000
 BREAKER TYPE RL-2000 SENSOR TAPS _____ MOUNTING B.I. D.O.
 FUSE CAT. NO. _____ CUBICLE CODE _____ THERMAL MEMORY ON OFF
 TRIP UNIT TYPE Static Trip III CATALOG NO. _____ ZONE INTLK TARGETS

Description	INSPECTED	CONDITION	CLEAN/LUBE
CUBICLE AND RACKING DEVICES	<input checked="" type="checkbox"/>	Good	
CONTACT FINGERS	<input checked="" type="checkbox"/>	Good	
LOADING AND ARCING CONTACTS	<input checked="" type="checkbox"/>	Good	
OVERCURRENT DEV. BATTERY	<input type="checkbox"/>		

Description	INSPECTED	CONDITION	CLEAN/LUBE
ARC CHUTES	<input checked="" type="checkbox"/>	Good	
AUXILIARY DEVICES	<input checked="" type="checkbox"/>	Good	
GROUND CONNECTION	<input checked="" type="checkbox"/>	Good	
LOAD CONDUCTOR NO. <u>0</u> Size <u>CU</u> <input type="radio"/> <u>AL</u> <input type="radio"/>			

SETTINGS AS FOUND LONG TIME PU 9.5 X _____ A = _____ A DELAY 3.5
 RATING PLUG(R) 2000 SHORT TIME PU 3 = _____ A DELAY .08 IPT IN OUT N/A
 SENSOR TAP _____ INST. PU _____ A ON OFF
 GRD. FLT. 3W 4W GRD. FLT. PU 20 = _____ A ON OFF DELAY 10 IPT IN OUT N/A

SETTINGS AS LEFT LONG TIME PU 9.5 X _____ A = _____ A DELAY 3.5
 RATING PLUG(R) 2000 SHORT TIME PU 3 = _____ A DELAY .08 IPT IN OUT N/A
 SENSOR TAP _____ INST. PU _____ A ON OFF
 GRD. FLT. 3W 4W GRD. FLT. PU 20 = _____ A ON OFF DELAY 10 IPT IN OUT N/A

FUNCTION	TEST AMPERES	CURRENT MULTIPLE	TIME BAND		POLE 1		POLE 2		POLE 3	
			MINIMUM	MAXIMUM	AS FOUND (seconds)	AS LEFT (seconds)	AS FOUND (seconds)	AS LEFT (seconds)	AS FOUND (seconds)	AS LEFT (seconds)
INSTANTANEOUS										
	IPU									
SHORT TIME	<u>0.580</u>					<u>18.382</u>		<u>18.382</u>		<u>18.382</u>
	STPU									
LONG TIME	<u>0.765</u>					<u>17.509</u>		<u>17.509</u>		<u>17.509</u>
	LTPU									
	VOLTAGE DROP @ LONG TIME TEST CURRENT									
GROUND FAULT	<u>.500</u>					<u>0.442</u>		<u>0.442</u>		<u>0.442</u>
	GFPV									

EQUIPMENT TEMPERATURE 22 °C TEMPERATURE CORRECTION FACTOR TO 20°C, TCF 1.1

INSULATION RESISTANCE	POLE 1 MΩ (P1-P2)		POLE 2 MΩ (P2-P3)		POLE 3 MΩ (P3-P4)	
	READING	20°C	READING	20°C	READING	20°C
POLE TO POLE	<u>2e+006</u>	<u>2,200,000</u>	<u>2e+006</u>	<u>2,200,000</u>	<u>2e+006</u>	<u>2,200,000</u>
POLE TO FRAME	<u>1.28e+006</u>	<u>1,408,000</u>	<u>2e+006</u>	<u>2,200,000</u>	<u>1.63e+006</u>	<u>1,793,000</u>
LINE TO LOAD	<u>2e+006</u>	<u>2,200,000</u>	<u>1.16e+006</u>	<u>1,276,000</u>	<u>2e+006</u>	<u>2,200,000</u>
CONTROL WIRING				COUNTER READING BEG/END		
READING		20°C		N/A	N/A	

POLE RESISTANCE - MICRO-OHMS		
READING		
POLE 1	POLE 2	POLE 3
<u>18</u>	<u>19</u>	<u>18</u>

TESTED BY: Matthew Falchetti / Andrew Kirk / Jason Watson



LOW VOLTAGE POWER CIRCUIT BREAKER TEST



PAGE _____

COMMENTS:

DEFICIENCIES:

EQUIPMENT USED

#	Manufacturer	Model	Serial / ID Number	Type	Calibration Date	Calibration Due
1	SIEMENS	Static Trip III Set	190021	Other	1/1/2024	1/1/2025
2	MEGGER	MIT1025	102435149	Other	1/1/2024	1/1/2025
3	AEMC	6240	157278WHDV	Other	1/1/2024	1/1/2025



VACUUM CIRCUIT BREAKER TEST



CUSTOMER Orange Cogen PAGE _____
 ADDRESS 1901 S Clear Springs; Bartow FL 33830 DATE 9/24/2024
 OWNER Orange Cogen; 1901 S Clear Springs; Bartow FL 33830 JOB # 624942
 SITE Orange Cogen TEST STATUS _____
 SUBSTATION Main MCC ASSET ID Tie Breaker T1-52
 EQUIPMENT 5 kV Breakers AMBIENT TEMPERATURE 70 °F HUMIDITY 56 %

MANUFACTURER Siemens SERIAL NUMBER R-99515A-3
 TYPE 5-GMI-250-1200-58 MODEL NO. _____ DATE MANUFACTURED 1994
 MAXIMUM VOLTAGE 5.00 kV AMPACITY 1200 OPERATING VOLTAGE 4.76 kV
 INTERRUPTING CAPACITY 29 kA @ _____ kV TO _____ kV = _____ mVA

Description	INSPECTED	CONDITION	CLEAN/LUBE
OVERALL CLEANLINESS	<input checked="" type="checkbox"/>	Good	C/L
INSULATING MEMBERS	<input checked="" type="checkbox"/>	Good	C
MECHANICAL CONNECTIONS	<input checked="" type="checkbox"/>	Good	C
STRUCTURAL MEMBERS	<input checked="" type="checkbox"/>	Good	
CUBICLE	<input checked="" type="checkbox"/>	Good	C
RACKING DEVICES	<input checked="" type="checkbox"/>	Good	
SHUTTER	<input checked="" type="checkbox"/>	Good	

Description	INSPECTED	CONDITION	CLEAN/LUBE
CONTACT FINGERS	<input checked="" type="checkbox"/>	Good	C/L
VACUUM BOTTLE	<input checked="" type="checkbox"/>	Good	C
CONTACT EROSION INDICATOR	<input checked="" type="checkbox"/>	Good	
OPERATING MECHANISM	<input checked="" type="checkbox"/>	Good	
CONTACT SEQUENCE	<input checked="" type="checkbox"/>	Good	
GROUND CONNECTION	<input checked="" type="checkbox"/>	Good	C
AUXILIARY DEVICES	<input checked="" type="checkbox"/>	Good	

INSULATION TEST VOLTAGE 2,500 kVDC EQUIPMENT TEMPERATURE 22 °C TEMPERATURE CORRECTION FACTOR TO 20°C, TCF 1.1
 MILLIWATT LOSS TEST VOLTAGE _____ kVAC HIGH POTENTIAL TEST VOLTAGE 16000 kVAC

INSULATION RESISTANCE	POLE 1 MEGOHMS (P1-P2)		POLE 2 MEGOHMS (P2-P3)		POLE 3 MEGOHMS (P1-P3)	
	READING	20°C	READING	20°C	READING	20°C
POLE TO POLE	5000000	5,500,000	5000000	5,500,000	5000000	5,500,000
POLE TO FRAME	430000	473,000.0	359000	394,900.0	475000	522,500.0
LINE TO FRAME	500000	550,000.0	5000000	5,500,000	350000	385,000.0
LOAD TO FRAME	438000	481,800.0	394000	433,400.0	412000	453,200.0
LINE TO LOAD						

CONTROL WIRING - MEGOHMS			
READING		20°C	

CONTACT MEASUREMENTS		POLE 1	POLE 2	POLE 3
CONTACT TRAVEL - INCHES				
POLE RESISTANCE MICRO-OHMS	RDG.			
	20°C			
CONTACT RESISTANCE MICRO-OHMS	RDG.	21	22	22
	20°C	20.8363	21.8285	21.8285

	POLE 1	POLE 2	POLE 3
HIGH POTENTIAL TI kVAC	PASS	PASS	PASS
MILLIWATT LOSS kVAC	0.03	0.03	0.03
	POLE 1	POLE 2	POLE 3
OPENING SPEED (ft/sec)	38.00	38.05	37.20
CLOSING SPEED (ft/sec)	39.90	40.05	40.60

COUNTER READING: BEG. 00667
 END 00669

COMMENTS: _____
 DEFICIENCIES: _____

EQUIPMENT USED	#	Manufacturer	Model	Serial / ID Number	Type	Calibration Date	Calibration Due
	1	MEGGER	MIT1025	102435149	Other	1/1/2024	1/1/2025
	2	AEMC	6240	157278WHDV	Other	1/1/2024	1/1/2025
	3	HVI	HVA 60	GH0238.24C008	Other	1/1/2024	1/1/2025
	4	VANGUARD	DIGITMR S2	150074	Other	1/1/2024	1/1/2025

TESTED BY: Matthew Falchetti / Andrew Kirk / Jason Watson



VACUUM CIRCUIT BREAKER TEST



CUSTOMER Orange Cogen PAGE _____
 ADDRESS 1901 S Clear Springs; Bartow FL 33830 DATE 9/26/2024
 OWNER Orange Cogen; 1901 S Clear Springs; Bartow FL 33830 JOB # 624942
 SITE Orange Cogen TEST STATUS _____ Pass
 SUBSTATION Main MCC ASSET ID Main Breaker - 52-2A
 EQUIPMENT 5 kV Breakers AMBIENT TEMPERATURE 70 °F HUMIDITY 56 %

MANUFACTURER Siemens SERIAL NUMBER R-99515A-4
 TYPE 5-GMI-250-1200-58 MODEL NO. _____ DATE MANUFACTURED 1994
 MAXIMUM VOLTAGE 5.00 kV AMPACITY 1200 OPERATING VOLTAGE 4.76 kV
 INTERRUPTING CAPACITY 29 kA @ _____ kV TO _____ kV = _____ mVA

Description	INSPECTED	CONDITION	CLEAN/LUBE
OVERALL CLEANLINESS	<input checked="" type="checkbox"/>	Good	C/L
INSULATING MEMBERS	<input checked="" type="checkbox"/>	Good	C
MECHANICAL CONNECTIONS	<input checked="" type="checkbox"/>	Good	C
STRUCTURAL MEMBERS	<input checked="" type="checkbox"/>	Good	
CUBICLE	<input checked="" type="checkbox"/>	Good	C
RACKING DEVICES	<input checked="" type="checkbox"/>	Good	
SHUTTER	<input checked="" type="checkbox"/>	Good	

Description	INSPECTED	CONDITION	CLEAN/LUBE
CONTACT FINGERS	<input checked="" type="checkbox"/>	Good	C/L
VACUUM BOTTLE	<input checked="" type="checkbox"/>	Good	C
CONTACT EROSION INDICATOR	<input checked="" type="checkbox"/>	Good	
OPERATING MECHANISM	<input checked="" type="checkbox"/>	Good	
CONTACT SEQUENCE	<input checked="" type="checkbox"/>	Good	
GROUND CONNECTION	<input checked="" type="checkbox"/>	Good	C
AUXILIARY DEVICES	<input checked="" type="checkbox"/>	Good	

INSULATION TEST VOLTAGE 2,500 kVDC EQUIPMENT TEMPERATURE 22 °C TEMPERATURE CORRECTION FACTOR TO 20°C, TCF 1.1
 MILLIWATT LOSS TEST VOLTAGE _____ kVAC HIGH POTENTIAL TEST VOLTAGE 16000 kVAC

INSULATION RESISTANCE	POLE 1 MEGOHMS (P1-P2)		POLE 2 MEGOHMS (P2-P3)		POLE 3 MEGOHMS (P1-P3)	
	READING	20°C	READING	20°C	READING	20°C
POLE TO POLE	5000000	5,500,000	5000000	5,500,000	5000000	5,500,000
POLE TO FRAME	5000000	5,500,000	5000000	5,500,000	5000000	5,500,000
LINE TO FRAME	5000000	5,500,000	5000000	5,500,000	5000000	5,500,000
LOAD TO FRAME	5000000	5,500,000	5000000	5,500,000	5000000	5,500,000
LINE TO LOAD	5000000	5,500,000	5000000	5,500,000	5000000	5,500,000

CONTROL WIRING - MEGOHMS			
READING		20°C	

CONTACT MEASUREMENTS		POLE 1	POLE 2	POLE 3
CONTACT TRAVEL - INCHES				
POLE RESISTANCE MICRO-OHMS	RDG.			
	20°C			
CONTACT RESISTANCE MICRO-OHMS	RDG.	22	22	22
	20°C	21.8285	21.8285	21.8285

	POLE 1	POLE 2	POLE 3
HIGH POTENTIAL TI kVAC	PASS	PASS	PASS
MILLIWATT LOSS kVAC	0.03	0.03	0.03

	POLE 1	POLE 2	POLE 3
OPENING SPEED (ft/sec)	40.05	39.90	39.20
CLOSING SPEED (ft/sec)	41.50	41.95	42.75

COUNTER READING: BEG. 00562
 END 00564

COMMENTS: _____
 DEFICIENCIES: _____

EQUIPMENT USED	#	Manufacturer	Model	Serial / ID Number	Type	Calibration Date	Calibration Due
	1	MEGGER	MIT1025	102435149	Other	1/1/2024	1/1/2025
	2	AEMC	6240	157278WHDV	Other	1/1/2024	1/1/2025
	3	HVI	HVA 60	GH0238.24C008	Other	1/1/2024	1/1/2025
	4	VANGUARD	DIGITMR S2	150074	Other	1/1/2024	1/1/2025

TESTED BY: Matthew Falchetti / Andrew Kirk / Jason Watson



VACUUM CIRCUIT BREAKER TEST



CUSTOMER Orange Cogen PAGE _____
 ADDRESS 1901 S Clear Springs; Bartow FL 33830 DATE 10/4/2024
 OWNER Orange Cogen; 1901 S Clear Springs; Bartow FL 33830 JOB # 624942
 SITE Orange Cogen TEST STATUS _____ Pass
 SUBSTATION Main MCC ASSET ID Station Service Transformer - 116E220
 EQUIPMENT 5 kV Breakers AMBIENT TEMPERATURE 70 °F HUMIDITY 56 %

MANUFACTURER Siemens SERIAL NUMBER R-99515A-1
 TYPE 5-GMI-250-1200-58 MODEL NO. _____ DATE MANUFACTURED 1994
 MAXIMUM VOLTAGE 5.00 kV AMPACITY 1200 OPERATING VOLTAGE 4.76 kV
 INTERRUPTING CAPACITY 29 kA @ _____ kV TO _____ kV = _____ mVA

Description	INSPECTED	CONDITION	CLEAN/LUBE
OVERALL CLEANLINESS	<input checked="" type="checkbox"/>	Good	C/L
INSULATING MEMBERS	<input checked="" type="checkbox"/>	Good	C
MECHANICAL CONNECTIONS	<input checked="" type="checkbox"/>	Good	C
STRUCTURAL MEMBERS	<input checked="" type="checkbox"/>	Good	
CUBICLE	<input checked="" type="checkbox"/>	Good	C
RACKING DEVICES	<input checked="" type="checkbox"/>	Good	
SHUTTER	<input checked="" type="checkbox"/>	Good	

Description	INSPECTED	CONDITION	CLEAN/LUBE
CONTACT FINGERS	<input checked="" type="checkbox"/>	Good	C/L
VACUUM BOTTLE	<input checked="" type="checkbox"/>	Good	C
CONTACT EROSION INDICATOR	<input checked="" type="checkbox"/>	Good	
OPERATING MECHANISM	<input checked="" type="checkbox"/>	Good	
CONTACT SEQUENCE	<input checked="" type="checkbox"/>	Good	
GROUND CONNECTION	<input checked="" type="checkbox"/>	Good	C
AUXILIARY DEVICES	<input checked="" type="checkbox"/>	Good	

INSULATION TEST VOLTAGE 2,500 kVDC EQUIPMENT TEMPERATURE 22 °C TEMPERATURE CORRECTION FACTOR TO 20°C, TCF 1.1
 MILLIWATT LOSS TEST VOLTAGE _____ kVAC HIGH POTENTIAL TEST VOLTAGE 16000 kVAC

INSULATION RESISTANCE	POLE 1 MEGOHMS (P1-P2)		POLE 2 MEGOHMS (P2-P3)		POLE 3 MEGOHMS (P1-P3)	
	READING	20°C	READING	20°C	READING	20°C
POLE TO POLE	8330000	9,163,000	12000000	1.32e+007	8170000	8,987,000
POLE TO FRAME	5200000	5,720,000	5890000	6,479,000	6650000	7,315,000
LINE TO FRAME	17500000	1.925e+007	6500000	7,150,000	5900000	6,490,000
LOAD TO FRAME	9420000	1.0362e+007	4180000	4,598,000	8680000	9,548,000
LINE TO LOAD	11600000	1.276e+007	16700000	1.837e+007	\	

CONTROL WIRING - MEGOHMS			
READING		20°C	

	POLE 1	POLE 2	POLE 3
HIGH POTENTIAL TI kVAC	PASS	PASS	PASS
MILLIWATT LOSS kVAC	5.8	5.8	6.0

CONTACT MEASUREMENTS		POLE 1	POLE 2	POLE 3
CONTACT TRAVEL - INCHES				
POLE RESISTANCE MICRO-OHMS	RDG.			
	20°C			
CONTACT RESISTANCE MICRO-OHMS	RDG.	21	22	22
	20°C	20.8363	21.8285	21.8285

	POLE 1	POLE 2	POLE 3
OPENING SPEED (ft/sec)	33.70	33.75	33.95
CLOSING SPEED (ft/sec)	41.25	41.15	40.90

COUNTER READING: BEG. 00493
 END 00495

COMMENTS: _____
 DEFICIENCIES: _____

EQUIPMENT USED	#	Manufacturer	Model	Serial / ID Number	Type	Calibration Date	Calibration Due
	1	MEGGER	MIT1025	102435149	Other	1/1/2024	1/1/2025
	2	AEMC	6240	157278WHDV	Other	1/1/2024	1/1/2025
	3	HVI	HVA 60	GH0238.24C008	Other	1/1/2024	1/1/2025
	4	VANGUARD	DIGITMR S2	150074	Other	1/1/2024	1/1/2025

TESTED BY: Matthew Falchetti / Andrew Kirk / Jason Watson



VACUUM CIRCUIT BREAKER TEST



CUSTOMER Orange Cogen PAGE _____
 ADDRESS 1901 S Clear Springs; Bartow FL 33830 DATE 9/26/2024
 OWNER Orange Cogen; 1901 S Clear Springs; Bartow FL 33830 JOB # 624942
 SITE Orange Cogen TEST STATUS _____ Pass
 SUBSTATION Main MCC ASSET ID Station Service Transformer - 216E220
 EQUIPMENT 5 kV Breakers AMBIENT TEMPERATURE 70 °F HUMIDITY 56 %

MANUFACTURER Siemens SERIAL NUMBER R-99515A-6
 TYPE 5-GMI-250-1200-58 MODEL NO. _____ DATE MANUFACTURED 1994
 MAXIMUM VOLTAGE 5.00 kV AMPACITY 1200 OPERATING VOLTAGE 4.76 kV
 INTERRUPTING CAPACITY 29 kA @ _____ kV TO _____ kV = _____ mVA

Description	INSPECTED	CONDITION	CLEAN/LUBE
OVERALL CLEANLINESS	<input checked="" type="checkbox"/>	Good	C/L
INSULATING MEMBERS	<input checked="" type="checkbox"/>	Good	C
MECHANICAL CONNECTIONS	<input checked="" type="checkbox"/>	Good	C
STRUCTURAL MEMBERS	<input checked="" type="checkbox"/>	Good	
CUBICLE	<input checked="" type="checkbox"/>	Good	C
RACKING DEVICES	<input checked="" type="checkbox"/>	Good	
SHUTTER	<input checked="" type="checkbox"/>	Good	

Description	INSPECTED	CONDITION	CLEAN/LUBE
CONTACT FINGERS	<input checked="" type="checkbox"/>	Good	C/L
VACUUM BOTTLE	<input checked="" type="checkbox"/>	Good	C
CONTACT EROSION INDICATOR	<input checked="" type="checkbox"/>	Good	
OPERATING MECHANISM	<input checked="" type="checkbox"/>	Good	
CONTACT SEQUENCE	<input checked="" type="checkbox"/>	Good	
GROUND CONNECTION	<input checked="" type="checkbox"/>	Good	C
AUXILIARY DEVICES	<input checked="" type="checkbox"/>	Good	

INSULATION TEST VOLTAGE 2,500 kVDC EQUIPMENT TEMPERATURE 22 °C TEMPERATURE CORRECTION FACTOR TO 20°C, TCF 1.1
 MILLIWATT LOSS TEST VOLTAGE _____ kVAC HIGH POTENTIAL TEST VOLTAGE 16000 kVAC

INSULATION RESISTANCE	POLE 1 MEGOHMS (P1-P2)		POLE 2 MEGOHMS (P2-P3)		POLE 3 MEGOHMS (P1-P3)	
	READING	20°C	READING	20°C	READING	20°C
POLE TO POLE	5000000	5,500,000	5000000	5,500,000	5000000	5,500,000
POLE TO FRAME	5000000	5,500,000	5000000	5,500,000	5000000	5,500,000
LINE TO FRAME	5000000	5,500,000	5000000	5,500,000	5000000	5,500,000
LOAD TO FRAME	496000	545,600.0	5000000	5,500,000	5000000	5,500,000
LINE TO LOAD	5000000	5,500,000	5000000	5,500,000	5000000	5,500,000

CONTROL WIRING - MEGOHMS			
READING		20°C	

CONTACT MEASUREMENTS		POLE 1	POLE 2	POLE 3
CONTACT TRAVEL - INCHES				
POLE RESISTANCE MICRO-OHMS	RDG.			
	20°C			
CONTACT RESISTANCE MICRO-OHMS	RDG.	23	22	22
	20°C	22.8207	21.8285	21.8285

	POLE 1	POLE 2	POLE 3
HIGH POTENTIAL TI kVAC	PASS	PASS	PASS
MILLIWATT LOSS kVAC	0.03	0.03	0.03
	POLE 1	POLE 2	POLE 3
OPENING SPEED (ft/sec)	37.55	37.45	37.60
CLOSING SPEED (ft/sec)	43.15	44.15	44.10

COUNTER READING: BEG. _____
 END _____

COMMENTS: _____
 DEFICIENCIES: _____

EQUIPMENT USED	#	Manufacturer	Model	Serial / ID Number	Type	Calibration Date	Calibration Due
	1	MEGGER	MIT1025	102435149	Other	1/1/2024	1/1/2025
	2	AEMC	6240	157278WHDV	Other	1/1/2024	1/1/2025
	3	HVI	HVA 60	GH0238.24C008	Other	1/1/2024	1/1/2025
	4	VANGUARD	DIGITMR S2	150074	Other	1/1/2024	1/1/2025

TESTED BY: Matthew Falchetti / Andrew Kirk / Jason Watson



VACUUM CIRCUIT BREAKER TEST



CUSTOMER Orange Cogen PAGE _____
 ADDRESS 1901 S Clear Springs; Bartow FL 33830 DATE 10/4/2024
 OWNER Orange Cogen; 1901 S Clear Springs; Bartow FL 33830 JOB # 624942
 SITE Orange Cogen TEST STATUS _____ Pass
 SUBSTATION Main MCC ASSET ID Main Breaker - 52-1A
 EQUIPMENT 5 kV Breakers AMBIENT TEMPERATURE 70 °F HUMIDITY 56 %

MANUFACTURER Siemens SERIAL NUMBER R-99515A-5
 TYPE 5-GMI-250-1200-58 MODEL NO. _____ DATE MANUFACTURED 1994
 MAXIMUM VOLTAGE 5.00 kV AMPACITY 1200 OPERATING VOLTAGE 4.76 kV
 INTERRUPTING CAPACITY 29 kA @ _____ kV TO _____ kV = _____ mVA

Description	INSPECTED	CONDITION	CLEAN/LUBE
OVERALL CLEANLINESS	<input checked="" type="checkbox"/>	Good	C/L
INSULATING MEMBERS	<input checked="" type="checkbox"/>	Good	C
MECHANICAL CONNECTIONS	<input checked="" type="checkbox"/>	Good	C
STRUCTURAL MEMBERS	<input checked="" type="checkbox"/>	Good	
CUBICLE	<input checked="" type="checkbox"/>	Good	C
RACKING DEVICES	<input checked="" type="checkbox"/>	Good	
SHUTTER	<input checked="" type="checkbox"/>	Good	

Description	INSPECTED	CONDITION	CLEAN/LUBE
CONTACT FINGERS	<input checked="" type="checkbox"/>	Good	C/L
VACUUM BOTTLE	<input checked="" type="checkbox"/>	Good	C
CONTACT EROSION INDICATOR	<input checked="" type="checkbox"/>	Good	
OPERATING MECHANISM	<input checked="" type="checkbox"/>	Good	
CONTACT SEQUENCE	<input checked="" type="checkbox"/>	Good	
GROUND CONNECTION	<input checked="" type="checkbox"/>	Good	C
AUXILIARY DEVICES	<input checked="" type="checkbox"/>	Good	

INSULATION TEST VOLTAGE 2,500 kVDC EQUIPMENT TEMPERATURE 22 °C TEMPERATURE CORRECTION FACTOR TO 20°C, TCF 1.1
 MILLIWATT LOSS TEST VOLTAGE _____ kVAC HIGH POTENTIAL TEST VOLTAGE 16000 kVAC

INSULATION RESISTANCE	POLE 1 MEGOHMS (P1-P2)		POLE 2 MEGOHMS (P2-P3)		POLE 3 MEGOHMS (P1-P3)	
	READING	20°C	READING	20°C	READING	20°C
POLE TO POLE	29000000	3.19e+007	16600000	1.826e+007	28600000	3.146e+007
POLE TO FRAME	5760000	6.336,000	6630000	7,293,000	8130000	8,943,000
LINE TO FRAME	10000000	1.1e+007	20700000	2.277e+007	18100000	1.991e+007
LOAD TO FRAME	13200000	1.452e+007	16700000	1.837e+007	13400000	1.474e+007
LINE TO LOAD	20000000	2.2e+007	17300000	1.903e+007	16200000	1.782e+007

CONTROL WIRING - MEGOHMS			
READING		20°C	

CONTACT MEASUREMENTS		POLE 1	POLE 2	POLE 3
CONTACT TRAVEL - INCHES				
POLE RESISTANCE MICRO-OHMS	RDG.			
	20°C			
CONTACT RESISTANCE MICRO-OHMS	RDG.	22	23	23
	20°C	21.8285	22.8207	22.8207

	POLE 1	POLE 2	POLE 3
HIGH POTENTIAL TI kVAC	PASS	PASS	PASS
MILLIWATT LOSS kVAC	6.0	5.8	5.6
	POLE 1	POLE 2	POLE 3
OPENING SPEED (ft/sec)	39.35	39.15	38.80
CLOSING SPEED (ft/sec)	36.00	35.85	36.30

COUNTER READING: BEG. 00615
 END 00617

COMMENTS: _____
 DEFICIENCIES: _____

EQUIPMENT USED	#	Manufacturer	Model	Serial / ID Number	Type	Calibration Date	Calibration Due
	1	MEGGER	MIT1025	102435149	Other	1/1/2024	1/1/2025
	2	AEMC	6240	157278WHDV	Other	1/1/2024	1/1/2025
	3	HVI	HVA 60	GH0238.24C008	Other	1/1/2024	1/1/2025
	4	VANGUARD	DIGITMR S2	150074	Other	1/1/2024	1/1/2025

TESTED BY: Matthew Falchetti / Andrew Kirk / Jason Watson

TESTING REPORTS

Orange Cogen – 2024 Post Outage IR Scan

prepared for

**Orange Cogeneration
1901 S Clear Springs Rd
Bartow, FL 33830**

prepared by

**TRC
Florida Division
Project # 624945**

October 2024





10/22/2024 9:49:07 AM



FLIR1022.jpg



79322879

Parameters

Emissivity	0.95
Distance	3.56 ft
Reflected temp.	68.0 °F
Atmospheric temp.	68.0 °F
Relative humidity	50.0%
Ext. optics temp.	68.0 °F
Ext. optics trans.	1.00

File information

File name	FLIR1022.jpg
File size	272 KB
Width	320
Height	240
Minimum temp.	70.8 °F
Maximum temp.	112.4 °F

Camera information

Camera model	FLIR T530
Lens	FOL10
Camera serial	79322879
Filter	
Range max.	248.0 °F
Range min.	-4.0 °F
Field of view	41.90

Measurements

Sp1	89.7 °F
-----	---------

Geolocation

Coordinates	
Compass degrees	

Isotherms

Text annotations



10/22/2024 9:49:21 AM



FLIR1024.jpg



79322879

Parameters

Emissivity	0.95
Distance	3.33 ft
Reflected temp.	68.0 °F
Atmospheric temp.	68.0 °F
Relative humidity	50.0%
Ext. optics temp.	68.0 °F
Ext. optics trans.	1.00

Measurements

Sp1	88.2 °F
-----	---------

File information

File name	FLIR1024.jpg
File size	292 KB
Width	320
Height	240
Minimum temp.	70.6 °F
Maximum temp.	106.8 °F

Geolocation

Coordinates	
Compass degrees	

Camera information

Camera model	FLIR T530
Lens	FOL10
Camera serial	79322879
Filter	
Range max.	248.0 °F
Range min.	-4.0 °F
Field of view	41.90

Isotherms

Text annotations



10/22/2024 9:49:39 AM



FLIR1026.jpg



79322879

Parameters

Emissivity	0.95
Distance	2.89 ft
Reflected temp.	68.0 °F
Atmospheric temp.	68.0 °F
Relative humidity	50.0%
Ext. optics temp.	68.0 °F
Ext. optics trans.	1.00

File information

File name	FLIR1026.jpg
File size	289 KB
Width	320
Height	240
Minimum temp.	70.2 °F
Maximum temp.	102.4 °F

Camera information

Camera model	FLIR T530
Lens	FOL10
Camera serial	79322879
Filter	
Range max.	248.0 °F
Range min.	-4.0 °F
Field of view	41.90

Measurements

Sp1	83.7 °F
-----	---------

Geolocation

Coordinates	
Compass degrees	

Isotherms

Text annotations



10/22/2024 9:49:52 AM

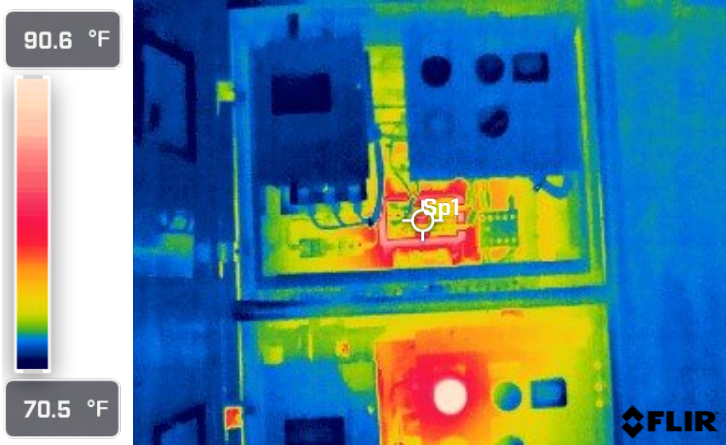

FLIR1028.jpg



79322879

Parameters

Emissivity	0.95
Distance	3.14 ft
Reflected temp.	68.0 °F
Atmospheric temp.	68.0 °F
Relative humidity	50.0%
Ext. optics temp.	68.0 °F
Ext. optics trans.	1.00

Measurements

Sp1	82.9 °F
-----	---------

File information

File name	FLIR1028.jpg
File size	269 KB
Width	320
Height	240
Minimum temp.	70.0 °F
Maximum temp.	102.9 °F

Geolocation

Coordinates	
Compass degrees	

Isotherms

Text annotations

Camera information

Camera model	FLIR T530
Lens	FOL10
Camera serial	79322879
Filter	
Range max.	248.0 °F
Range min.	-4.0 °F
Field of view	41.90



10/22/2024 9:50:06 AM

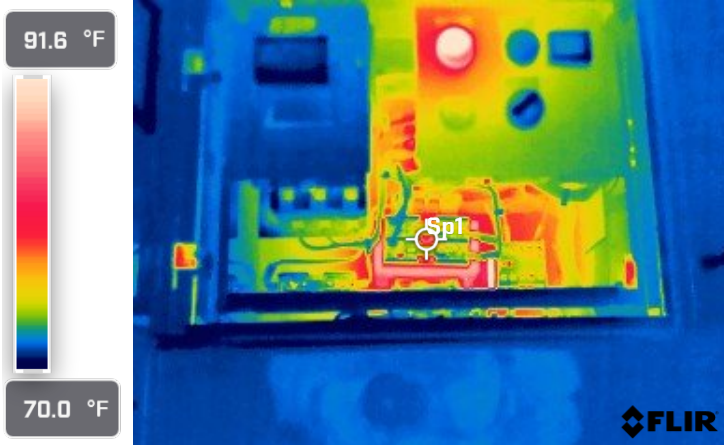

FLIR1030.jpg



79322879

Parameters

Emissivity	0.95
Distance	2.38 ft
Reflected temp.	68.0 °F
Atmospheric temp.	68.0 °F
Relative humidity	50.0%
Ext. optics temp.	68.0 °F
Ext. optics trans.	1.00

File information

File name	FLIR1030.jpg
File size	244 KB
Width	320
Height	240
Minimum temp.	69.5 °F
Maximum temp.	106.2 °F

Camera information

Camera model	FLIR T530
Lens	FOL10
Camera serial	79322879
Filter	
Range max.	248.0 °F
Range min.	-4.0 °F
Field of view	41.90

Measurements

Sp1	84.0 °F
-----	---------

Geolocation

Coordinates	
Compass degrees	

Isotherms

Text annotations



10/22/2024 11:29:08 AM



FLIR1032.jpg



79322879

Parameters

Emissivity	0.95
Distance	20.46 ft
Reflected temp.	68.0 °F
Atmospheric temp.	68.0 °F
Relative humidity	50.0%
Ext. optics temp.	68.0 °F
Ext. optics trans.	1.00

File information

File name	FLIR1032.jpg
File size	238 KB
Width	320
Height	240
Minimum temp.	10.1 °F
Maximum temp.	112.6 °F

Camera information

Camera model	FLIR T530
Lens	FOL10
Camera serial	79322879
Filter	
Range max.	248.0 °F
Range min.	-4.0 °F
Field of view	41.90

Measurements

Sp1	92.6 °F
Sp2	93.4 °F

Geolocation

Coordinates	
Compass degrees	

Isotherms

Text annotations



10/22/2024 11:29:25 AM

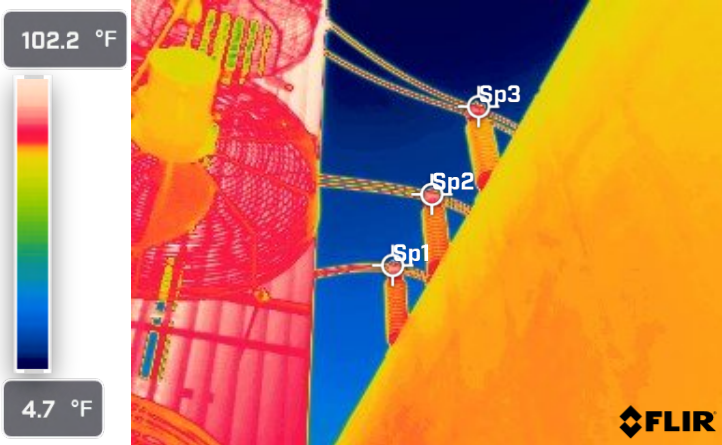

FLIR1034.jpg



79322879

Parameters

Emissivity	0.95
Distance	18.72 ft
Reflected temp.	68.0 °F
Atmospheric temp.	68.0 °F
Relative humidity	50.0%
Ext. optics temp.	68.0 °F
Ext. optics trans.	1.00

File information

File name	FLIR1034.jpg
File size	264 KB
Width	320
Height	240
Minimum temp.	4.6 °F
Maximum temp.	105.6 °F

Camera information

Camera model	FLIR T530
Lens	FOL10
Camera serial	79322879
Filter	
Range max.	248.0 °F
Range min.	-4.0 °F
Field of view	41.90

Measurements

Sp1	89.6 °F
Sp2	93.2 °F
Sp3	85.0 °F

Geolocation

Coordinates	
Compass degrees	

Isotherms

Text annotations



10/22/2024 11:30:49 AM

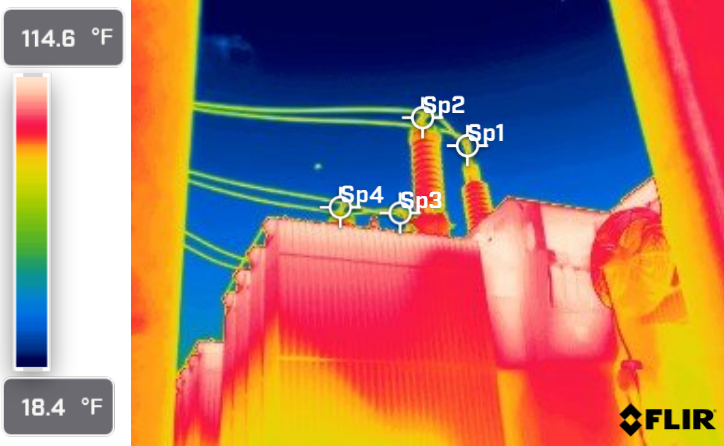

FLIR1036.jpg



79322879

Parameters

Emissivity	0.95
Distance	21.09 ft
Reflected temp.	68.0 °F
Atmospheric temp.	68.0 °F
Relative humidity	50.0%
Ext. optics temp.	68.0 °F
Ext. optics trans.	1.00

File information

File name	FLIR1036.jpg
File size	260 KB
Width	320
Height	240
Minimum temp.	18.1 °F
Maximum temp.	116.3 °F

Camera information

Camera model	FLIR T530
Lens	FOL10
Camera serial	79322879
Filter	
Range max.	248.0 °F
Range min.	-4.0 °F
Field of view	41.90

Measurements

Sp1	92.0 °F
Sp2	94.0 °F
Sp3	95.2 °F
Sp4	93.0 °F

Geolocation

Coordinates	27°52'12.8"N 81°49'30.3"W
Compass degrees	

Isotherms

Text annotations



10/22/2024 11:31:07 AM

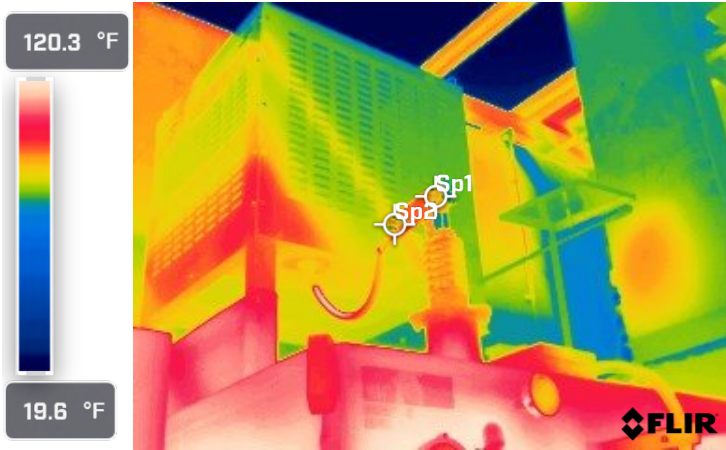

FLIR1038.jpg



79322879

Parameters

Emissivity	0.95
Distance	7.08 ft
Reflected temp.	68.0 °F
Atmospheric temp.	68.0 °F
Relative humidity	50.0%
Ext. optics temp.	68.0 °F
Ext. optics trans.	1.00

File information

File name	FLIR1038.jpg
File size	298 KB
Width	320
Height	240
Minimum temp.	19.5 °F
Maximum temp.	123.4 °F

Camera information

Camera model	FLIR T530
Lens	FOL10
Camera serial	79322879
Filter	
Range max.	248.0 °F
Range min.	-4.0 °F
Field of view	41.90

Measurements

Sp1	98.2 °F
Sp2	98.0 °F

Geolocation

Coordinates	27°52'12.9"N 81°49'30.3"W
Compass degrees	

Isotherms

Text annotations



10/22/2024 11:31:30 AM

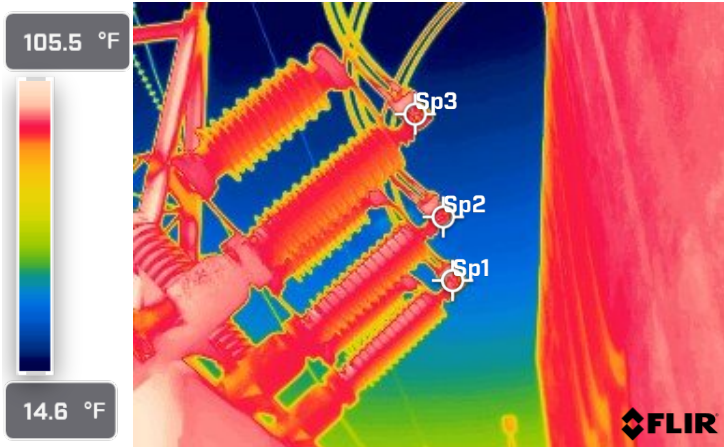

FLIR1040.jpg

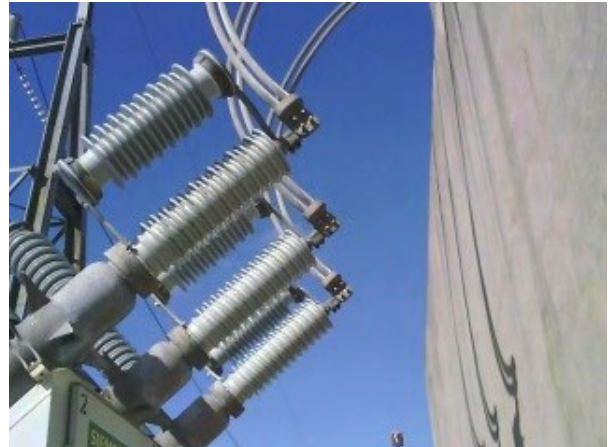

79322879

Parameters

Emissivity	0.95
Distance	12.15 ft
Reflected temp.	68.0 °F
Atmospheric temp.	68.0 °F
Relative humidity	50.0%
Ext. optics temp.	68.0 °F
Ext. optics trans.	1.00

File information

File name	FLIR1040.jpg
File size	300 KB
Width	320
Height	240
Minimum temp.	14.2 °F
Maximum temp.	107.8 °F

Camera information

Camera model	FLIR T530
Lens	FOL10
Camera serial	79322879
Filter	
Range max.	248.0 °F
Range min.	-4.0 °F
Field of view	41.90

Measurements

Sp1	94.9 °F
Sp2	93.7 °F
Sp3	95.5 °F

Geolocation

Coordinates	27°52'12.7"N 81°49'30.4"W
Compass degrees	

Isotherms

Text annotations



10/22/2024 11:31:58 AM

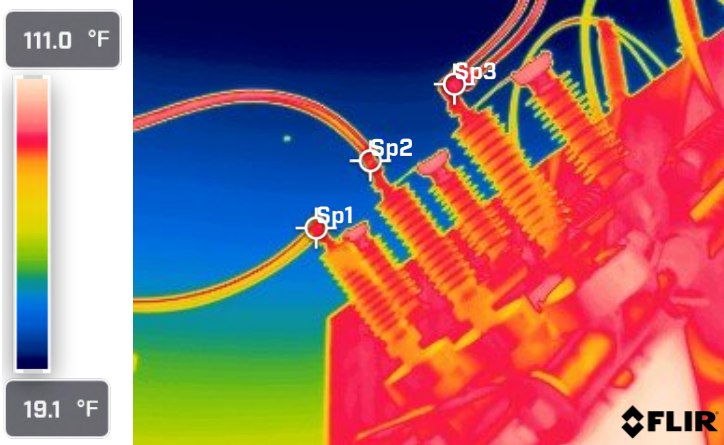

FLIR1042.jpg



79322879

Parameters

Emissivity	0.95
Distance	12.87 ft
Reflected temp.	68.0 °F
Atmospheric temp.	68.0 °F
Relative humidity	50.0%
Ext. optics temp.	68.0 °F
Ext. optics trans.	1.00

File information

File name	FLIR1042.jpg
File size	308 KB
Width	320
Height	240
Minimum temp.	18.9 °F
Maximum temp.	111.6 °F

Camera information

Camera model	FLIR T530
Lens	FOL10
Camera serial	79322879
Filter	
Range max.	248.0 °F
Range min.	-4.0 °F
Field of view	41.90

Measurements

Sp1	94.0 °F
Sp2	91.5 °F
Sp3	96.1 °F

Geolocation

Coordinates	27°52'12.7"N 81°49'30.3"W
Compass degrees	

Isotherms

Text annotations



10/22/2024 11:34:52 AM

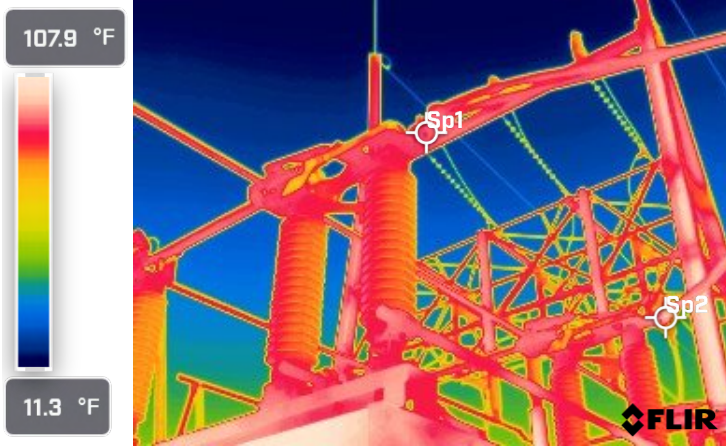

FLIR1044.jpg



79322879

Parameters

Emissivity	0.95
Distance	5.00 ft
Reflected temp.	68.0 °F
Atmospheric temp.	68.0 °F
Relative humidity	50.0%
Ext. optics temp.	68.0 °F
Ext. optics trans.	1.00

File information

File name	FLIR1044.jpg
File size	359 KB
Width	320
Height	240
Minimum temp.	11.5 °F
Maximum temp.	109.0 °F

Camera information

Camera model	FLIR T530
Lens	FOL10
Camera serial	79322879
Filter	
Range max.	248.0 °F
Range min.	-4.0 °F
Field of view	41.90

Measurements

Sp1	94.5 °F
Sp2	100.4 °F

Geolocation

Coordinates	
Compass degrees	

Isotherms

Text annotations



10/22/2024 11:35:22 AM



FLIR1046.jpg



79322879

Parameters

Emissivity	0.95
Distance	18.26 ft
Reflected temp.	68.0 °F
Atmospheric temp.	68.0 °F
Relative humidity	50.0%
Ext. optics temp.	68.0 °F
Ext. optics trans.	1.00

File information

File name	FLIR1046.jpg
File size	300 KB
Width	320
Height	240
Minimum temp.	22.6 °F
Maximum temp.	222.5 °F

Camera information

Camera model	FLIR T530
Lens	FOL10
Camera serial	79322879
Filter	
Range max.	248.0 °F
Range min.	-4.0 °F
Field of view	41.90

Measurements

Sp1	98.5 °F
Sp2	97.0 °F
Sp3	96.1 °F

Geolocation

Coordinates	
Compass degrees	

Isotherms

Text annotations



10/22/2024 11:35:44 AM



FLIR1048.jpg



79322879

Parameters

Emissivity	0.95
Distance	17.20 ft
Reflected temp.	68.0 °F
Atmospheric temp.	68.0 °F
Relative humidity	50.0%
Ext. optics temp.	68.0 °F
Ext. optics trans.	1.00

File information

File name	FLIR1048.jpg
File size	371 KB
Width	320
Height	240
Minimum temp.	22.6 °F
Maximum temp.	105.8 °F

Camera information

Camera model	FLIR T530
Lens	FOL10
Camera serial	79322879
Filter	
Range max.	248.0 °F
Range min.	-4.0 °F
Field of view	41.90

Measurements

Sp1	90.6 °F
Sp2	92.4 °F
Sp3	91.9 °F

Geolocation

Coordinates	27°52'12.5"N 81°49'29.7"W
Compass degrees	

Isotherms

Text annotations



10/22/2024 11:36:02 AM



FLIR1050.jpg



79322879

Parameters

Emissivity	0.95
Distance	17.22 ft
Reflected temp.	68.0 °F
Atmospheric temp.	68.0 °F
Relative humidity	50.0%
Ext. optics temp.	68.0 °F
Ext. optics trans.	1.00

File information

File name	FLIR1050.jpg
File size	404 KB
Width	320
Height	240
Minimum temp.	24.0 °F
Maximum temp.	105.4 °F

Camera information

Camera model	FLIR T530
Lens	FOL10
Camera serial	79322879
Filter	
Range max.	248.0 °F
Range min.	-4.0 °F
Field of view	41.90

Measurements

Sp1	92.9 °F
Sp2	91.2 °F
Sp3	91.5 °F

Geolocation

Coordinates	27°52'12.4"N 81°49'30.3"W
Compass degrees	

Isotherms

Text annotations



10/22/2024 11:36:18 AM

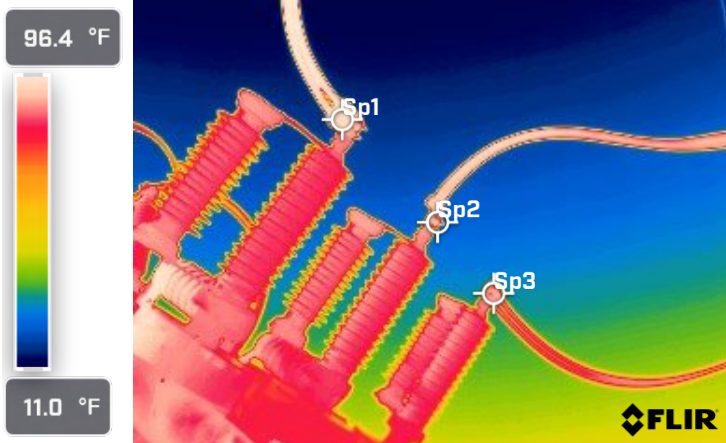

FLIR1052.jpg



79322879

Parameters

Emissivity	0.95
Distance	12.01 ft
Reflected temp.	68.0 °F
Atmospheric temp.	68.0 °F
Relative humidity	50.0%
Ext. optics temp.	68.0 °F
Ext. optics trans.	1.00

File information

File name	FLIR1052.jpg
File size	278 KB
Width	320
Height	240
Minimum temp.	10.8 °F
Maximum temp.	99.0 °F

Camera information

Camera model	FLIR T530
Lens	FOL10
Camera serial	79322879
Filter	
Range max.	248.0 °F
Range min.	-4.0 °F
Field of view	41.90

Measurements

Sp1	94.7 °F
Sp2	89.3 °F
Sp3	90.5 °F

Geolocation

Coordinates	27°52'12.5"N 81°49'30.6"W
Compass degrees	

Isotherms

Text annotations



10/22/2024 11:36:33 AM

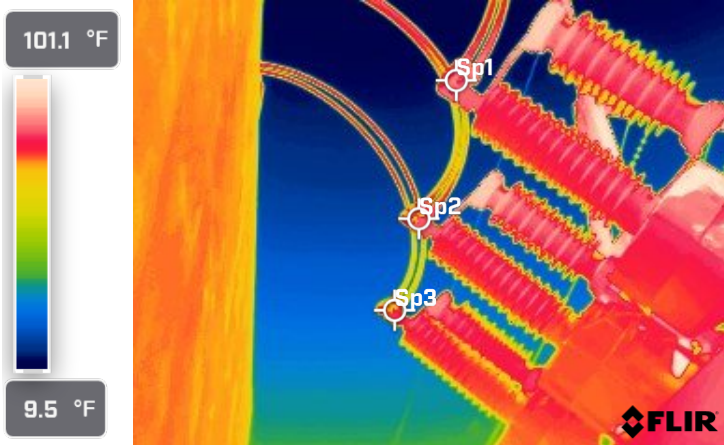

FLIR1054.jpg



79322879

Parameters

Emissivity	0.95
Distance	10.81 ft
Reflected temp.	68.0 °F
Atmospheric temp.	68.0 °F
Relative humidity	50.0%
Ext. optics temp.	68.0 °F
Ext. optics trans.	1.00

File information

File name	FLIR1054.jpg
File size	295 KB
Width	320
Height	240
Minimum temp.	9.3 °F
Maximum temp.	109.6 °F

Camera information

Camera model	FLIR T530
Lens	FOL10
Camera serial	79322879
Filter	
Range max.	248.0 °F
Range min.	-4.0 °F
Field of view	41.90

Measurements

Sp1	85.5 °F
Sp2	88.0 °F
Sp3	83.7 °F

Geolocation

Coordinates	27°52'12.4"N 81°49'30.6"W
Compass degrees	

Isotherms

Text annotations



10/22/2024 11:36:50 AM

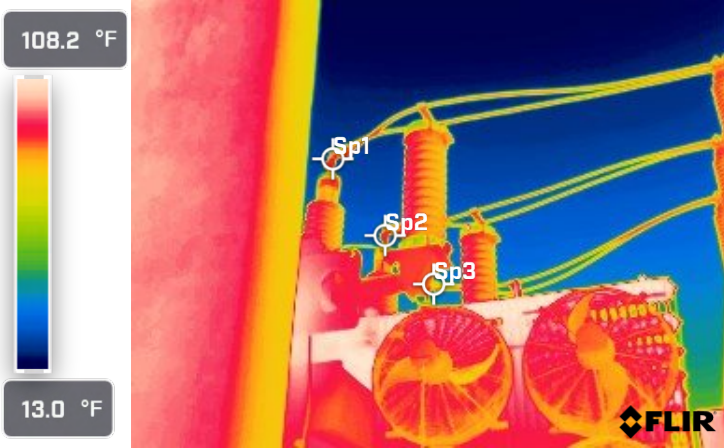

FLIR1056.jpg



79322879

Parameters

Emissivity	0.95
Distance	14.69 ft
Reflected temp.	68.0 °F
Atmospheric temp.	68.0 °F
Relative humidity	50.0%
Ext. optics temp.	68.0 °F
Ext. optics trans.	1.00

File information

File name	FLIR1056.jpg
File size	293 KB
Width	320
Height	240
Minimum temp.	12.8 °F
Maximum temp.	135.9 °F

Camera information

Camera model	FLIR T530
Lens	FOL10
Camera serial	79322879
Filter	
Range max.	248.0 °F
Range min.	-4.0 °F
Field of view	41.90

Measurements

Sp1	94.1 °F
Sp2	93.5 °F
Sp3	80.3 °F

Geolocation

Coordinates	27°52'12.3"N 81°49'30.5"W
Compass degrees	

Isotherms

Text annotations



10/22/2024 11:37:12 AM

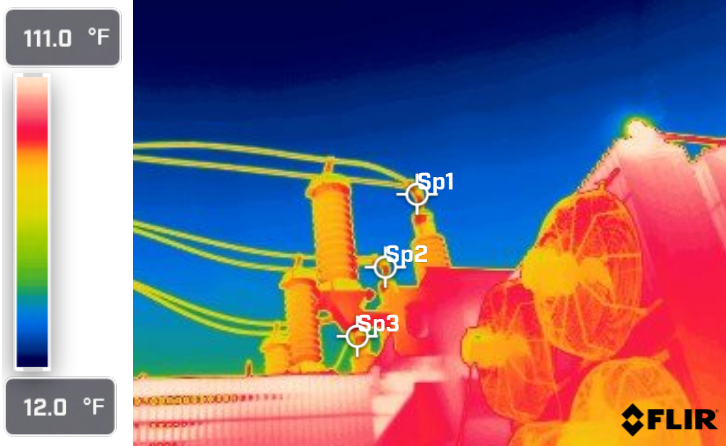

FLIR1058.jpg



79322879

Parameters

Emissivity	0.95
Distance	18.70 ft
Reflected temp.	68.0 °F
Atmospheric temp.	68.0 °F
Relative humidity	50.0%
Ext. optics temp.	68.0 °F
Ext. optics trans.	1.00

File information

File name	FLIR1058.jpg
File size	229 KB
Width	320
Height	240
Minimum temp.	11.5 °F
Maximum temp.	266.4 °F

Camera information

Camera model	FLIR T530
Lens	FOL10
Camera serial	79322879
Filter	
Range max.	248.0 °F
Range min.	-4.0 °F
Field of view	41.90

Measurements

Sp1	89.4 °F
Sp2	93.2 °F
Sp3	91.5 °F

Geolocation

Coordinates	27°52'12.2"N 81°49'30.9"W
Compass degrees	

Isotherms

Text annotations



10/22/2024 11:37:34 AM

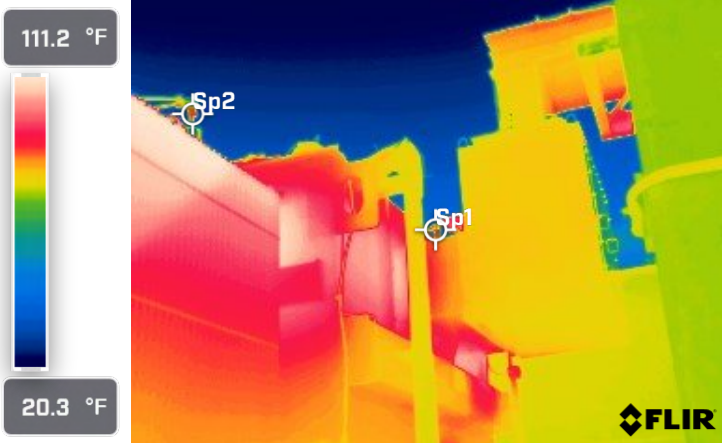

FLIR1060.jpg



79322879

Parameters

Emissivity	0.95
Distance	17.99 ft
Reflected temp.	68.0 °F
Atmospheric temp.	68.0 °F
Relative humidity	50.0%
Ext. optics temp.	68.0 °F
Ext. optics trans.	1.00

File information

File name	FLIR1060.jpg
File size	224 KB
Width	320
Height	240
Minimum temp.	20.0 °F
Maximum temp.	111.5 °F

Camera information

Camera model	FLIR T530
Lens	FOL10
Camera serial	79322879
Filter	
Range max.	248.0 °F
Range min.	-4.0 °F
Field of view	41.90

Measurements

Sp1	93.7 °F
Sp2	93.3 °F

Geolocation

Coordinates	27°52'12.0"N 81°49'30.9"W
Compass degrees	

Isotherms

Text annotations



10/22/2024 11:37:59 AM



FLIR1062.jpg



79322879

Parameters

Emissivity	0.95
Distance	9.13 ft
Reflected temp.	68.0 °F
Atmospheric temp.	68.0 °F
Relative humidity	50.0%
Ext. optics temp.	68.0 °F
Ext. optics trans.	1.00

File information

File name	FLIR1062.jpg
File size	316 KB
Width	320
Height	240
Minimum temp.	20.0 °F
Maximum temp.	115.0 °F

Camera information

Camera model	FLIR T530
Lens	FOL10
Camera serial	79322879
Filter	
Range max.	248.0 °F
Range min.	-4.0 °F
Field of view	41.90

Measurements

Sp1	93.5 °F
-----	---------

Geolocation

Coordinates	27°52'12.0"N 81°49'30.4"W
Compass degrees	

Isotherms

Text annotations



10/22/2024 11:38:54 AM

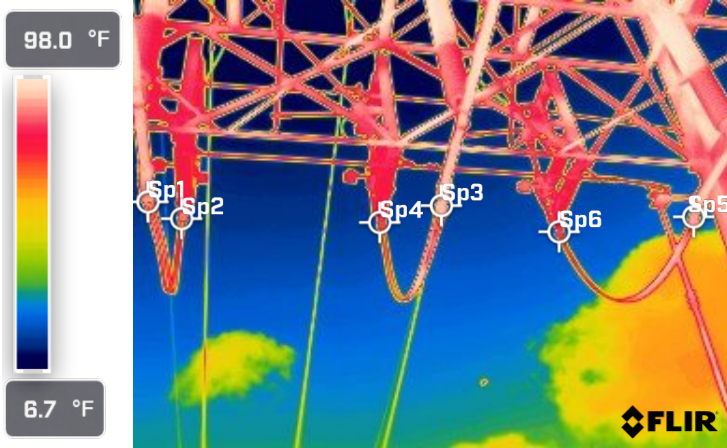

FLIR1064.jpg



79322879

Parameters

Emissivity	0.95
Distance	19.63 ft
Reflected temp.	68.0 °F
Atmospheric temp.	68.0 °F
Relative humidity	50.0%
Ext. optics temp.	68.0 °F
Ext. optics trans.	1.00

File information

File name	FLIR1064.jpg
File size	330 KB
Width	320
Height	240
Minimum temp.	6.3 °F
Maximum temp.	99.6 °F

Camera information

Camera model	FLIR T530
Lens	FOL10
Camera serial	79322879
Filter	
Range max.	248.0 °F
Range min.	-4.0 °F
Field of view	41.90

Measurements

Sp1	79.9 °F
Sp2	89.6 °F
Sp3	94.3 °F
Sp4	86.5 °F
Sp5	92.3 °F
Sp6	86.5 °F

Geolocation

Coordinates	27°52'12.5"N 81°49'30.6"W
Compass degrees	

Isotherms

Text annotations



10/22/2024 11:39:40 AM

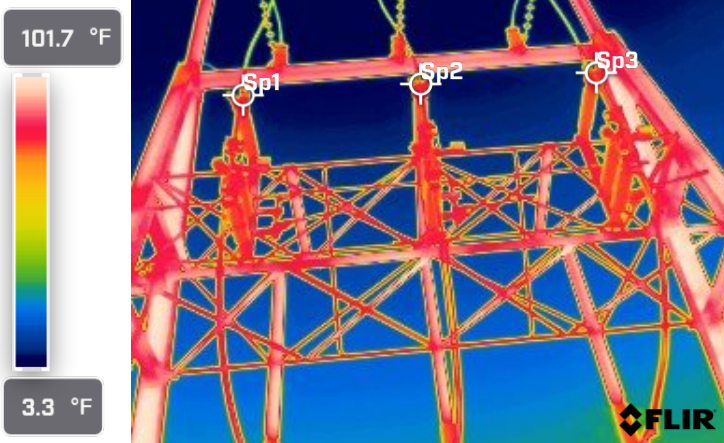

FLIR1066.jpg



79322879

Parameters

Emissivity	0.95
Distance	28.17 ft
Reflected temp.	68.0 °F
Atmospheric temp.	68.0 °F
Relative humidity	50.0%
Ext. optics temp.	68.0 °F
Ext. optics trans.	1.00

File information

File name	FLIR1066.jpg
File size	324 KB
Width	320
Height	240
Minimum temp.	3.1 °F
Maximum temp.	103.0 °F

Camera information

Camera model	FLIR T530
Lens	FOL10
Camera serial	79322879
Filter	
Range max.	248.0 °F
Range min.	-4.0 °F
Field of view	41.90

Measurements

Sp1	81.4 °F
Sp2	86.2 °F
Sp3	84.5 °F

Geolocation

Coordinates	27°52'12.6"N 81°49'31.2"W
Compass degrees	

Isotherms

Text annotations

TESTING REPORTS

Orange Cogen – 2024 Pre Outage IR Scan

prepared for

**Orange Cogeneration
1901 S Clear Springs Rd
Bartow, FL 33830**

prepared by

**TRC
Florida Division
Project # 624945**

October 2024





9/3/2024 9:37:49 AM

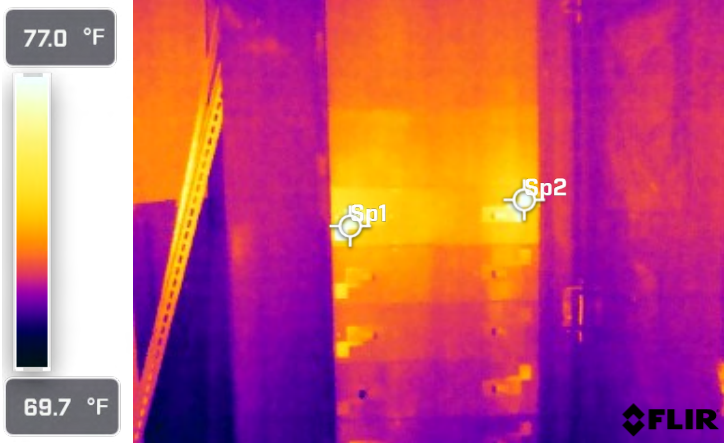

FLIR1827.jpg



79320978

Parameters

Emissivity	0.95
Distance	4.59 ft
Reflected temp.	32.0 °F
Atmospheric temp.	74.0 °F
Relative humidity	50.0%
Ext. optics temp.	68.0 °F
Ext. optics trans.	1.00

File information

File name	FLIR1827.jpg
File size	398 KB
Width	320
Height	240
Minimum temp.	70.3 °F
Maximum temp.	81.0 °F

Camera information

Camera model	FLIR T530
Lens	FOL10
Camera serial	79320978
Filter	
Range max.	248.0 °F
Range min.	-4.0 °F
Field of view	41.90

Measurements

Sp1	77.6 °F
Sp2	79.9 °F

Geolocation

Coordinates	
Compass degrees	

Isotherms

Text annotations



9/3/2024 9:41:49 AM

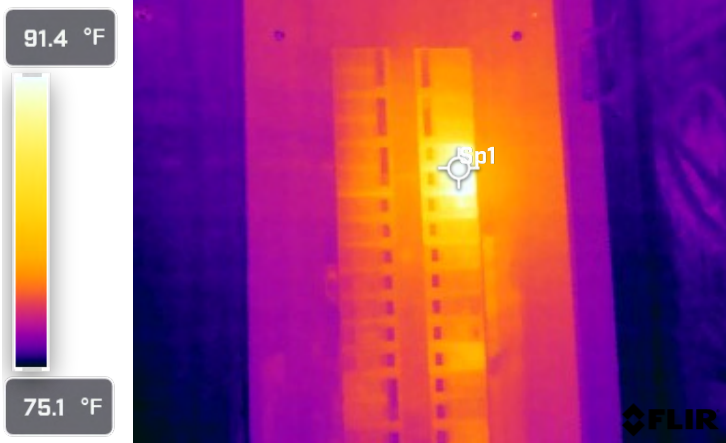

FLIR1829.jpg



79320978

Parameters

Emissivity	0.95
Distance	3.00 ft
Reflected temp.	32.0 °F
Atmospheric temp.	74.0 °F
Relative humidity	50.0%
Ext. optics temp.	68.0 °F
Ext. optics trans.	1.00

Measurements

Sp1	93.6 °F
-----	---------

File information

File name	FLIR1829.jpg
File size	444 KB
Width	320
Height	240
Minimum temp.	75.0 °F
Maximum temp.	93.7 °F

Geolocation

Coordinates	
Compass degrees	

Isotherms

Camera information

Camera model	FLIR T530
Lens	FOL10
Camera serial	79320978
Filter	
Range max.	248.0 °F
Range min.	-4.0 °F
Field of view	41.90

Text annotations



9/3/2024 9:42:49 AM

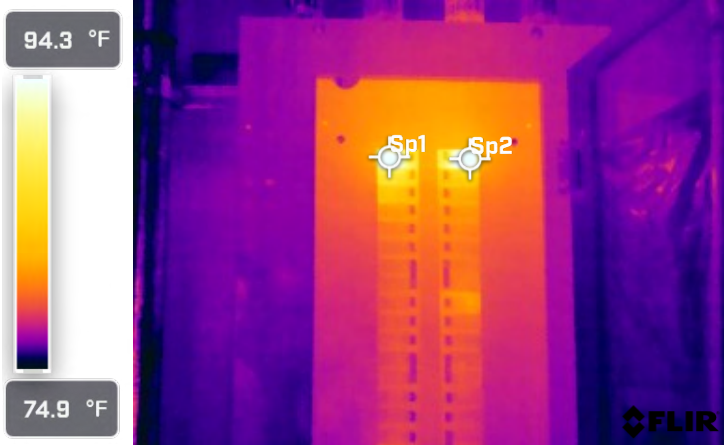

FLIR1831.jpg



79320978

Parameters

Emissivity	0.95
Distance	3.00 ft
Reflected temp.	32.0 °F
Atmospheric temp.	74.0 °F
Relative humidity	50.0%
Ext. optics temp.	68.0 °F
Ext. optics trans.	1.00

Measurements

Sp1	100.4 °F
Sp2	102.3 °F

File information

File name	FLIR1831.jpg
File size	472 KB
Width	320
Height	240
Minimum temp.	74.0 °F
Maximum temp.	104.2 °F

Geolocation

Coordinates	
Compass degrees	

Camera information

Camera model	FLIR T530
Lens	FOL10
Camera serial	79320978
Filter	
Range max.	248.0 °F
Range min.	-4.0 °F
Field of view	41.90

Isotherms

Text annotations



9/3/2024 9:44:47 AM

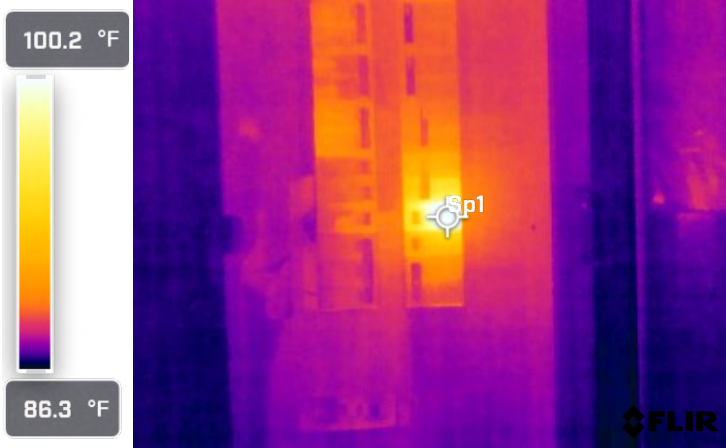

FLIR1833.jpg



79320978

Parameters

Emissivity	0.95
Distance	3.00 ft
Reflected temp.	32.0 °F
Atmospheric temp.	74.0 °F
Relative humidity	50.0%
Ext. optics temp.	68.0 °F
Ext. optics trans.	1.00

Measurements

Sp1	106.5 °F
-----	----------

File information

File name	FLIR1833.jpg
File size	442 KB
Width	320
Height	240
Minimum temp.	86.2 °F
Maximum temp.	106.5 °F

Geolocation

Coordinates	
Compass degrees	

Camera information

Camera model	FLIR T530
Lens	FOL10
Camera serial	79320978
Filter	
Range max.	248.0 °F
Range min.	-4.0 °F
Field of view	41.90

Isotherms

Text annotations



9/3/2024 9:46:33 AM

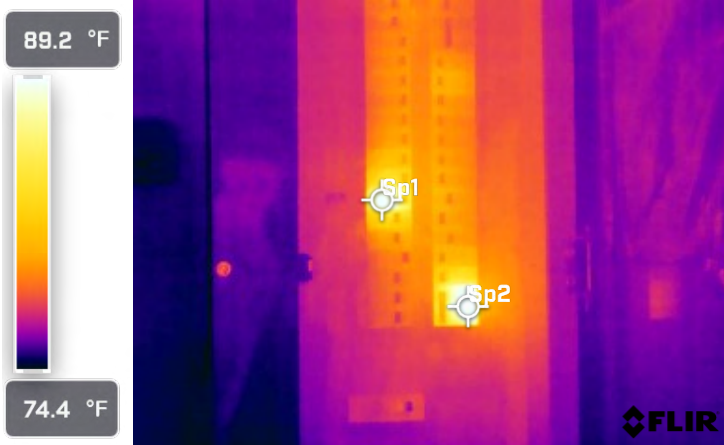

FLIR1835.jpg



79320978

Parameters

Emissivity	0.95
Distance	3.00 ft
Reflected temp.	32.0 °F
Atmospheric temp.	74.0 °F
Relative humidity	50.0%
Ext. optics temp.	68.0 °F
Ext. optics trans.	1.00

Measurements

Sp1	90.6 °F
Sp2	93.3 °F

File information

File name	FLIR1835.jpg
File size	447 KB
Width	320
Height	240
Minimum temp.	73.6 °F
Maximum temp.	93.3 °F

Camera information

Camera model	FLIR T530
Lens	FOL10
Camera serial	79320978
Filter	
Range max.	248.0 °F
Range min.	-4.0 °F
Field of view	41.90

Geolocation

Coordinates	
Compass degrees	

Isotherms

Text annotations



9/3/2024 9:50:38 AM

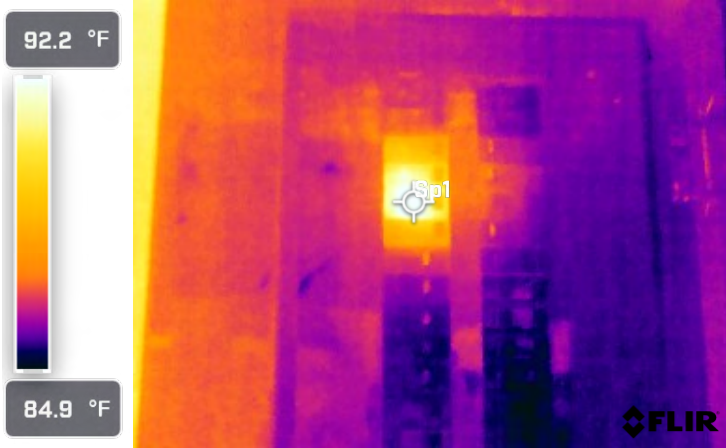

FLIR1837.jpg



79320978

Parameters

Emissivity	0.95
Distance	3.00 ft
Reflected temp.	32.0 °F
Atmospheric temp.	74.0 °F
Relative humidity	50.0%
Ext. optics temp.	68.0 °F
Ext. optics trans.	1.00

Measurements

Sp1	92.5 °F
-----	---------

File information

File name	FLIR1837.jpg
File size	423 KB
Width	320
Height	240
Minimum temp.	84.7 °F
Maximum temp.	93.2 °F

Geolocation

Coordinates	
Compass degrees	

Isotherms

Camera information

Camera model	FLIR T530
Lens	FOL10
Camera serial	79320978
Filter	
Range max.	248.0 °F
Range min.	-4.0 °F
Field of view	41.90

Text annotations



9/3/2024 9:55:01 AM

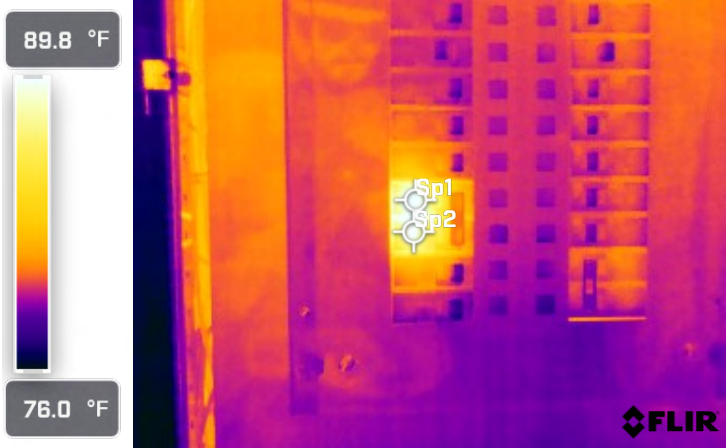

FLIR1839.jpg



79320978

Parameters

Emissivity	0.95
Distance	3.00 ft
Reflected temp.	32.0 °F
Atmospheric temp.	74.0 °F
Relative humidity	50.0%
Ext. optics temp.	68.0 °F
Ext. optics trans.	1.00

Measurements

Sp1	91.0 °F
Sp2	89.6 °F

File information

File name	FLIR1839.jpg
File size	461 KB
Width	320
Height	240
Minimum temp.	75.8 °F
Maximum temp.	92.1 °F

Geolocation

Coordinates	
Compass degrees	

Camera information

Camera model	FLIR T530
Lens	FOL10
Camera serial	79320978
Filter	
Range max.	248.0 °F
Range min.	-4.0 °F
Field of view	41.90

Isotherms

Text annotations



9/3/2024 9:59:59 AM

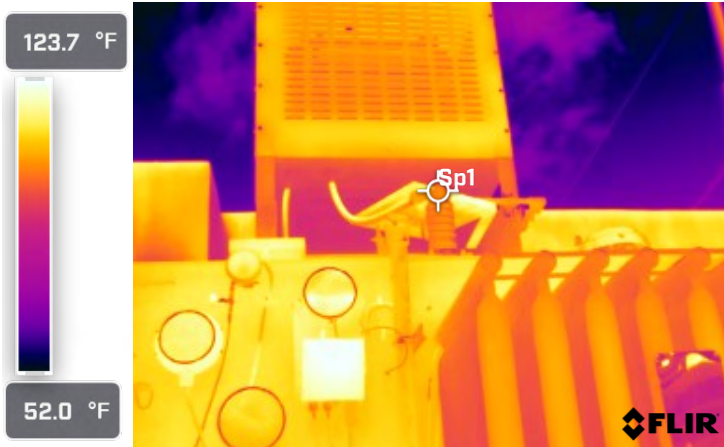

FLIR1841.jpg



79320978

Parameters

Emissivity	0.95
Distance	3.00 ft
Reflected temp.	32.0 °F
Atmospheric temp.	74.0 °F
Relative humidity	50.0%
Ext. optics temp.	68.0 °F
Ext. optics trans.	1.00

Measurements

Sp1	105.0 °F
-----	----------

File information

File name	FLIR1841.jpg
File size	838 KB
Width	320
Height	240
Minimum temp.	50.6 °F
Maximum temp.	131.1 °F

Geolocation

Coordinates	27°52'12.0"N 81°49'29.9"W
Compass degrees	

Camera information

Camera model	FLIR T530
Lens	FOL10
Camera serial	79320978
Filter	
Range max.	248.0 °F
Range min.	-4.0 °F
Field of view	41.90

Isotherms

Text annotations



9/3/2024 10:01:15 AM



FLIR1843.jpg



79320978

Parameters

Emissivity	0.95
Distance	3.00 ft
Reflected temp.	32.0 °F
Atmospheric temp.	74.0 °F
Relative humidity	50.0%
Ext. optics temp.	68.0 °F
Ext. optics trans.	1.00

Measurements

Sp1	105.5 °F
Sp2	104.4 °F

File information

File name	FLIR1843.jpg
File size	918 KB
Width	320
Height	240
Minimum temp.	38.6 °F
Maximum temp.	123.9 °F

Geolocation

Coordinates	27°52'12.1"N 81°49'30.1"W
Compass degrees	

Camera information

Camera model	FLIR T530
Lens	FOL10
Camera serial	79320978
Filter	
Range max.	248.0 °F
Range min.	-4.0 °F
Field of view	41.90

Isotherms

Text annotations



9/3/2024 10:01:51 AM

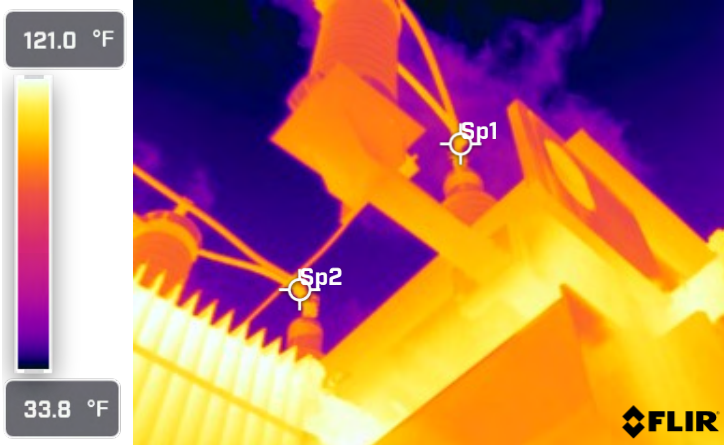

FLIR1845.jpg



79320978

Parameters

Emissivity	0.95
Distance	3.00 ft
Reflected temp.	32.0 °F
Atmospheric temp.	74.0 °F
Relative humidity	50.0%
Ext. optics temp.	68.0 °F
Ext. optics trans.	1.00

Measurements

Sp1	104.9 °F
Sp2	106.7 °F

File information

File name	FLIR1845.jpg
File size	773 KB
Width	320
Height	240
Minimum temp.	33.6 °F
Maximum temp.	121.8 °F

Geolocation

Coordinates	27°52'12.2"N 81°49'30.5"W
Compass degrees	

Camera information

Camera model	FLIR T530
Lens	FOL10
Camera serial	79320978
Filter	
Range max.	248.0 °F
Range min.	-4.0 °F
Field of view	41.90

Isotherms

Text annotations



9/3/2024 10:02:23 AM



FLIR1847.jpg



79320978

Parameters

Emissivity	0.95
Distance	3.00 ft
Reflected temp.	32.0 °F
Atmospheric temp.	74.0 °F
Relative humidity	50.0%
Ext. optics temp.	68.0 °F
Ext. optics trans.	1.00

Measurements

Sp1	99.2 °F
-----	---------

File information

File name	FLIR1847.jpg
File size	675 KB
Width	320
Height	240
Minimum temp.	51.8 °F
Maximum temp.	122.2 °F

Camera information

Camera model	FLIR T530
Lens	FOL10
Camera serial	79320978
Filter	
Range max.	248.0 °F
Range min.	-4.0 °F
Field of view	41.90

Geolocation

Coordinates	27°52'12.0"N 81°49'30.7"W
Compass degrees	

Isotherms

Text annotations



9/3/2024 10:02:50 AM



FLIR1849.jpg



79320978

Parameters

Emissivity	0.95
Distance	3.00 ft
Reflected temp.	32.0 °F
Atmospheric temp.	74.0 °F
Relative humidity	50.0%
Ext. optics temp.	68.0 °F
Ext. optics trans.	1.00

File information

File name	FLIR1849.jpg
File size	732 KB
Width	320
Height	240
Minimum temp.	43.3 °F
Maximum temp.	190.4 °F

Camera information

Camera model	FLIR T530
Lens	FOL10
Camera serial	79320978
Filter	
Range max.	248.0 °F
Range min.	-4.0 °F
Field of view	41.90

Measurements

Sp1	102.0 °F
Sp2	103.7 °F
Sp3	102.3 °F

Geolocation

Coordinates	27°52'12.2"N 81°49'30.7"W
Compass degrees	

Isotherms

Text annotations



9/3/2024 10:03:32 AM

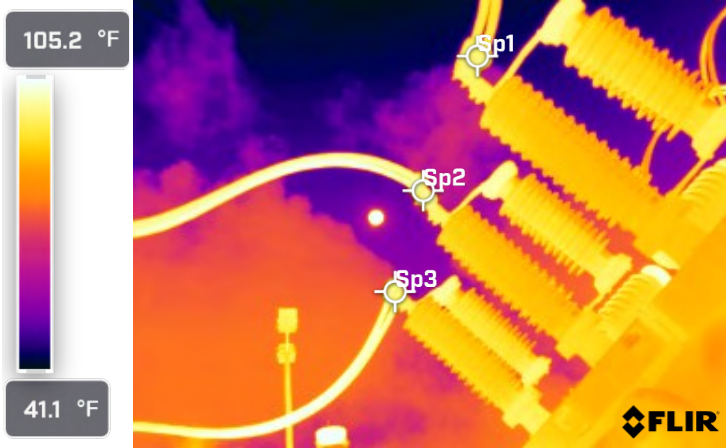

FLIR1851.jpg



79320978

Parameters

Emissivity	0.95
Distance	3.00 ft
Reflected temp.	32.0 °F
Atmospheric temp.	74.0 °F
Relative humidity	50.0%
Ext. optics temp.	68.0 °F
Ext. optics trans.	1.00

Measurements

Sp1	98.7 °F
Sp2	100.3 °F
Sp3	95.9 °F

File information

File name	FLIR1851.jpg
File size	808 KB
Width	320
Height	240
Minimum temp.	41.2 °F
Maximum temp.	266.4 °F

Geolocation

Coordinates	27°52'12.4"N 81°49'30.6"W
Compass degrees	

Isotherms

Camera information

Camera model	FLIR T530
Lens	FOL10
Camera serial	79320978
Filter	
Range max.	248.0 °F
Range min.	-4.0 °F
Field of view	41.90

Text annotations



9/3/2024 10:04:26 AM

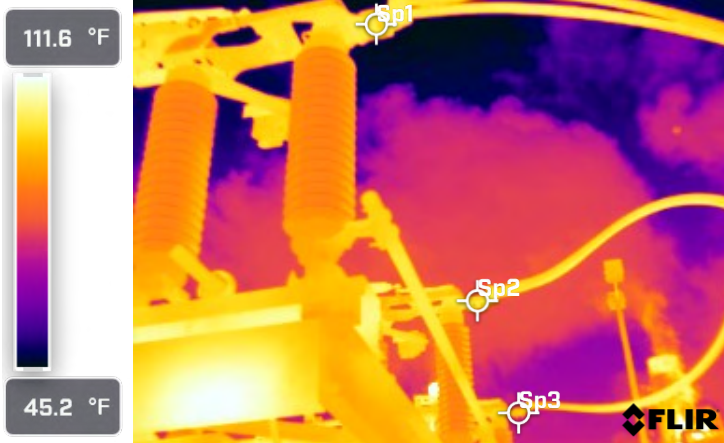

FLIR1853.jpg



79320978

Parameters

Emissivity	0.95
Distance	3.00 ft
Reflected temp.	32.0 °F
Atmospheric temp.	74.0 °F
Relative humidity	50.0%
Ext. optics temp.	68.0 °F
Ext. optics trans.	1.00

File information

File name	FLIR1853.jpg
File size	834 KB
Width	320
Height	240
Minimum temp.	43.3 °F
Maximum temp.	225.6 °F

Camera information

Camera model	FLIR T530
Lens	FOL10
Camera serial	79320978
Filter	
Range max.	248.0 °F
Range min.	-4.0 °F
Field of view	41.90

Measurements

Sp1	101.6 °F
Sp2	101.8 °F
Sp3	99.0 °F

Geolocation

Coordinates	27°52'12.3"N 81°49'30.7"W
Compass degrees	

Isotherms

Text annotations



9/3/2024 10:04:53 AM



FLIR1855.jpg



79320978

Parameters

Emissivity	0.95
Distance	3.00 ft
Reflected temp.	32.0 °F
Atmospheric temp.	74.0 °F
Relative humidity	50.0%
Ext. optics temp.	68.0 °F
Ext. optics trans.	1.00

Measurements

Sp1	99.5 °F
Sp2	99.7 °F
Sp3	100.2 °F

File information

File name	FLIR1855.jpg
File size	819 KB
Width	320
Height	240
Minimum temp.	49.0 °F
Maximum temp.	266.4 °F

Geolocation

Coordinates	27°52'12.4"N 81°49'30.7"W
Compass degrees	

Isotherms

Camera information

Camera model	FLIR T530
Lens	FOL10
Camera serial	79320978
Filter	
Range max.	248.0 °F
Range min.	-4.0 °F
Field of view	41.90

Text annotations



9/3/2024 10:05:21 AM

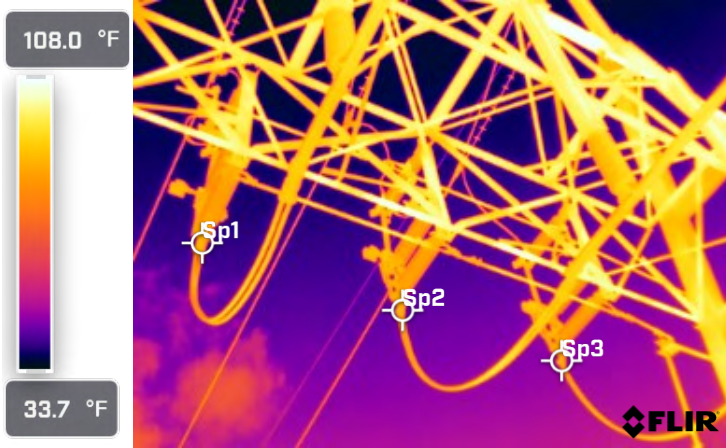

FLIR1857.jpg



79320978

Parameters

Emissivity	0.95
Distance	3.00 ft
Reflected temp.	32.0 °F
Atmospheric temp.	74.0 °F
Relative humidity	50.0%
Ext. optics temp.	68.0 °F
Ext. optics trans.	1.00

Measurements

Sp1	89.1 °F
Sp2	88.5 °F
Sp3	89.3 °F

File information

File name	FLIR1857.jpg
File size	1105 KB
Width	320
Height	240
Minimum temp.	33.5 °F
Maximum temp.	109.7 °F

Geolocation

Coordinates	27°52'12.4"N 81°49'30.6"W
Compass degrees	

Isotherms

Text annotations

Camera information

Camera model	FLIR T530
Lens	FOL10
Camera serial	79320978
Filter	
Range max.	248.0 °F
Range min.	-4.0 °F
Field of view	41.90



9/3/2024 10:05:46 AM

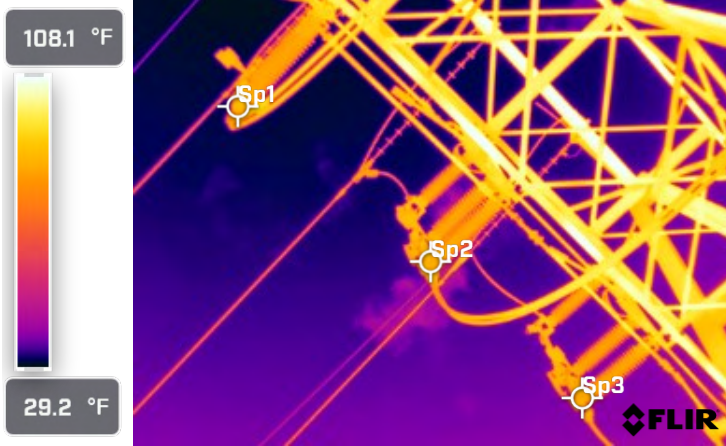

FLIR1859.jpg



79320978

Parameters

Emissivity	0.95
Distance	3.00 ft
Reflected temp.	32.0 °F
Atmospheric temp.	74.0 °F
Relative humidity	50.0%
Ext. optics temp.	68.0 °F
Ext. optics trans.	1.00

Measurements

Sp1	89.8 °F
Sp2	86.8 °F
Sp3	85.7 °F

File information

File name	FLIR1859.jpg
File size	975 KB
Width	320
Height	240
Minimum temp.	29.3 °F
Maximum temp.	110.0 °F

Geolocation

Coordinates	27°52'12.4"N 81°49'30.7"W
Compass degrees	

Isotherms

Text annotations

Camera information

Camera model	FLIR T530
Lens	FOL10
Camera serial	79320978
Filter	
Range max.	248.0 °F
Range min.	-4.0 °F
Field of view	41.90



9/3/2024 10:06:11 AM



FLIR1861.jpg



79320978

Parameters

Emissivity	0.95
Distance	3.00 ft
Reflected temp.	32.0 °F
Atmospheric temp.	74.0 °F
Relative humidity	50.0%
Ext. optics temp.	68.0 °F
Ext. optics trans.	1.00

File information

File name	FLIR1861.jpg
File size	823 KB
Width	320
Height	240
Minimum temp.	47.9 °F
Maximum temp.	266.4 °F

Camera information

Camera model	FLIR T530
Lens	FOL10
Camera serial	79320978
Filter	
Range max.	248.0 °F
Range min.	-4.0 °F
Field of view	41.90

Measurements

Sp1	102.3 °F
Sp2	102.9 °F
Sp3	102.3 °F

Geolocation

Coordinates	27°52'12.6"N 81°49'30.7"W
Compass degrees	

Isotherms

Text annotations



9/3/2024 10:06:40 AM

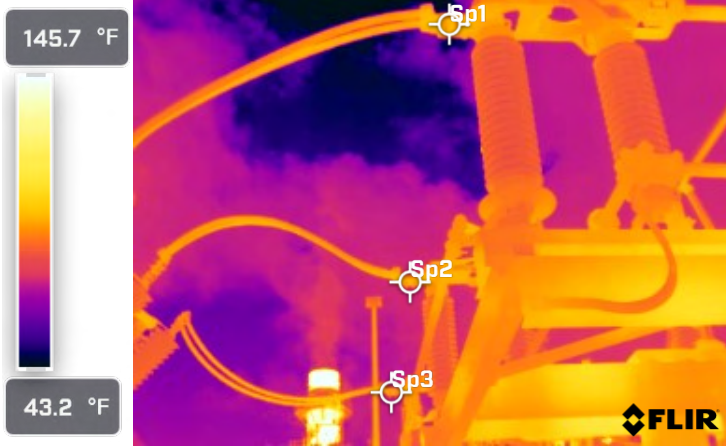

FLIR1863.jpg



79320978

Parameters

Emissivity	0.95
Distance	3.00 ft
Reflected temp.	32.0 °F
Atmospheric temp.	74.0 °F
Relative humidity	50.0%
Ext. optics temp.	68.0 °F
Ext. optics trans.	1.00

Measurements

Sp1	102.0 °F
Sp2	102.5 °F
Sp3	100.7 °F

File information

File name	FLIR1863.jpg
File size	841 KB
Width	320
Height	240
Minimum temp.	42.9 °F
Maximum temp.	266.4 °F

Geolocation

Coordinates	27°52'12.7"N 81°49'30.7"W
Compass degrees	

Isotherms

Text annotations

Camera information

Camera model	FLIR T530
Lens	FOL10
Camera serial	79320978
Filter	
Range max.	248.0 °F
Range min.	-4.0 °F
Field of view	41.90



9/3/2024 10:07:07 AM

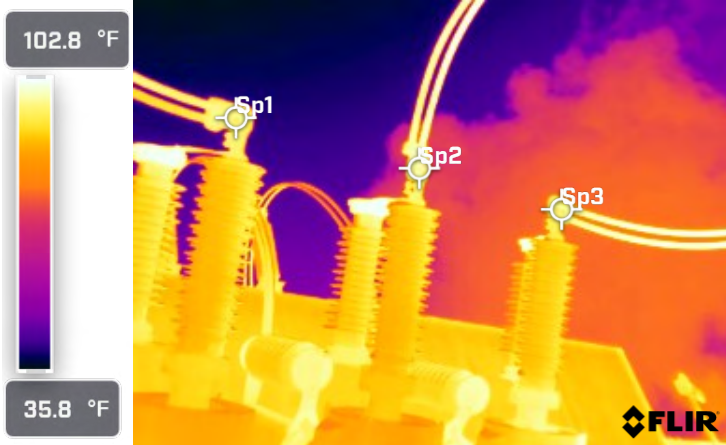

FLIR1865.jpg



79320978

Parameters

Emissivity	0.95
Distance	3.00 ft
Reflected temp.	32.0 °F
Atmospheric temp.	74.0 °F
Relative humidity	50.0%
Ext. optics temp.	68.0 °F
Ext. optics trans.	1.00

Measurements

Sp1	96.0 °F
Sp2	98.9 °F
Sp3	96.3 °F

File information

File name	FLIR1865.jpg
File size	748 KB
Width	320
Height	240
Minimum temp.	35.9 °F
Maximum temp.	104.6 °F

Geolocation

Coordinates	27°52'12.7"N 81°49'30.6"W
Compass degrees	

Isotherms

Camera information

Camera model	FLIR T530
Lens	FOL10
Camera serial	79320978
Filter	
Range max.	248.0 °F
Range min.	-4.0 °F
Field of view	41.90

Text annotations



9/3/2024 10:07:37 AM

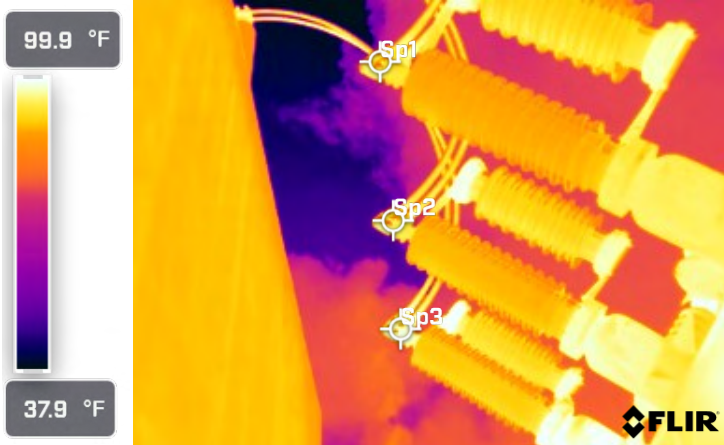

FLIR1867.jpg



79320978

Parameters

Emissivity	0.95
Distance	3.00 ft
Reflected temp.	32.0 °F
Atmospheric temp.	74.0 °F
Relative humidity	50.0%
Ext. optics temp.	68.0 °F
Ext. optics trans.	1.00

Measurements

Sp1	90.9 °F
Sp2	95.3 °F
Sp3	99.9 °F

File information

File name	FLIR1867.jpg
File size	722 KB
Width	320
Height	240
Minimum temp.	37.3 °F
Maximum temp.	102.8 °F

Geolocation

Coordinates	27°52'12.7"N 81°49'30.6"W
Compass degrees	

Isotherms

Camera information

Camera model	FLIR T530
Lens	FOL10
Camera serial	79320978
Filter	
Range max.	248.0 °F
Range min.	-4.0 °F
Field of view	41.90

Text annotations



9/3/2024 10:08:04 AM



FLIR1869.jpg



79320978

Parameters

Emissivity	0.95
Distance	3.00 ft
Reflected temp.	32.0 °F
Atmospheric temp.	74.0 °F
Relative humidity	50.0%
Ext. optics temp.	68.0 °F
Ext. optics trans.	1.00

Measurements

Sp1	104.2 °F
Sp2	102.5 °F

File information

File name	FLIR1869.jpg
File size	733 KB
Width	320
Height	240
Minimum temp.	41.7 °F
Maximum temp.	118.5 °F

Geolocation

Coordinates	27°52'12.9"N 81°49'30.8"W
Compass degrees	

Camera information

Camera model	FLIR T530
Lens	FOL10
Camera serial	79320978
Filter	
Range max.	248.0 °F
Range min.	-4.0 °F
Field of view	41.90

Isotherms

Text annotations



9/3/2024 10:08:32 AM

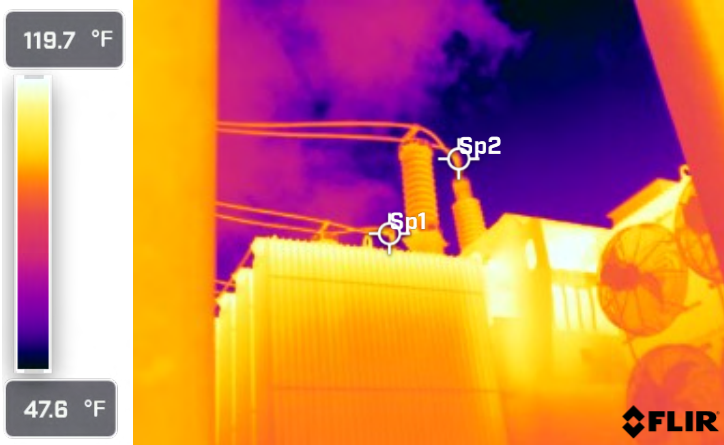

FLIR1871.jpg



79320978

Parameters

Emissivity	0.95
Distance	3.00 ft
Reflected temp.	32.0 °F
Atmospheric temp.	74.0 °F
Relative humidity	50.0%
Ext. optics temp.	68.0 °F
Ext. optics trans.	1.00

Measurements

Sp1	102.3 °F
Sp2	97.2 °F

File information

File name	FLIR1871.jpg
File size	780 KB
Width	320
Height	240
Minimum temp.	46.7 °F
Maximum temp.	121.5 °F

Geolocation

Coordinates	27°52'12.8"N 81°49'30.3"W
Compass degrees	

Camera information

Camera model	FLIR T530
Lens	FOL10
Camera serial	79320978
Filter	
Range max.	248.0 °F
Range min.	-4.0 °F
Field of view	41.90

Isotherms

Text annotations



9/3/2024 10:09:12 AM



FLIR1873.jpg



79320978

Parameters

Emissivity	0.95
Distance	3.00 ft
Reflected temp.	32.0 °F
Atmospheric temp.	74.0 °F
Relative humidity	50.0%
Ext. optics temp.	68.0 °F
Ext. optics trans.	1.00

Measurements

Sp1	101.1 °F
-----	----------

File information

File name	FLIR1873.jpg
File size	784 KB
Width	320
Height	240
Minimum temp.	48.7 °F
Maximum temp.	117.8 °F

Geolocation

Coordinates	27°52'13.0"N 81°49'30.4"W
Compass degrees	

Camera information

Camera model	FLIR T530
Lens	FOL10
Camera serial	79320978
Filter	
Range max.	248.0 °F
Range min.	-4.0 °F
Field of view	41.90

Isotherms

Text annotations



9/3/2024 10:09:55 AM



FLIR1875.jpg



79320978

Parameters

Emissivity	0.95
Distance	3.00 ft
Reflected temp.	32.0 °F
Atmospheric temp.	74.0 °F
Relative humidity	50.0%
Ext. optics temp.	68.0 °F
Ext. optics trans.	1.00

Measurements

Sp1	92.4 °F
-----	---------

File information

File name	FLIR1875.jpg
File size	681 KB
Width	320
Height	240
Minimum temp.	42.8 °F
Maximum temp.	111.8 °F

Geolocation

Coordinates	27°52'12.9"N 81°49'30.2"W
Compass degrees	

Isotherms

Text annotations

Camera information

Camera model	FLIR T530
Lens	FOL10
Camera serial	79320978
Filter	
Range max.	248.0 °F
Range min.	-4.0 °F
Field of view	41.90



9/3/2024 10:11:09 AM



FLIR1877.jpg



79320978

Parameters

Emissivity	0.95
Distance	3.00 ft
Reflected temp.	32.0 °F
Atmospheric temp.	74.0 °F
Relative humidity	50.0%
Ext. optics temp.	68.0 °F
Ext. optics trans.	1.00

Measurements

Sp1	93.9 °F
-----	---------

File information

File name	FLIR1877.jpg
File size	549 KB
Width	320
Height	240
Minimum temp.	31.1 °F
Maximum temp.	101.3 °F

Geolocation

Coordinates	27°52'12.0"N 81°49'30.4"W
Compass degrees	

Isotherms

Camera information

Camera model	FLIR T530
Lens	FOL10
Camera serial	79320978
Filter	
Range max.	248.0 °F
Range min.	-4.0 °F
Field of view	41.90

Text annotations



9/3/2024 10:24:42 AM

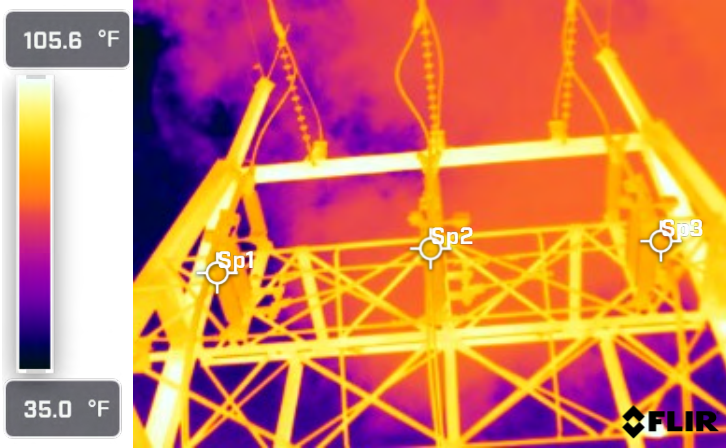

FLIR1879.jpg



79320978

Parameters

Emissivity	0.95
Distance	3.00 ft
Reflected temp.	32.0 °F
Atmospheric temp.	74.0 °F
Relative humidity	50.0%
Ext. optics temp.	68.0 °F
Ext. optics trans.	1.00

Measurements

Sp1	89.8 °F
Sp2	90.8 °F
Sp3	88.9 °F

File information

File name	FLIR1879.jpg
File size	986 KB
Width	320
Height	240
Minimum temp.	35.1 °F
Maximum temp.	266.4 °F

Geolocation

Coordinates	27°52'12.5"N 81°49'31.0"W
Compass degrees	

Isotherms

Camera information

Camera model	FLIR T530
Lens	FOL10
Camera serial	79320978
Filter	
Range max.	248.0 °F
Range min.	-4.0 °F
Field of view	41.90

Text annotations



9/3/2024 10:25:22 AM

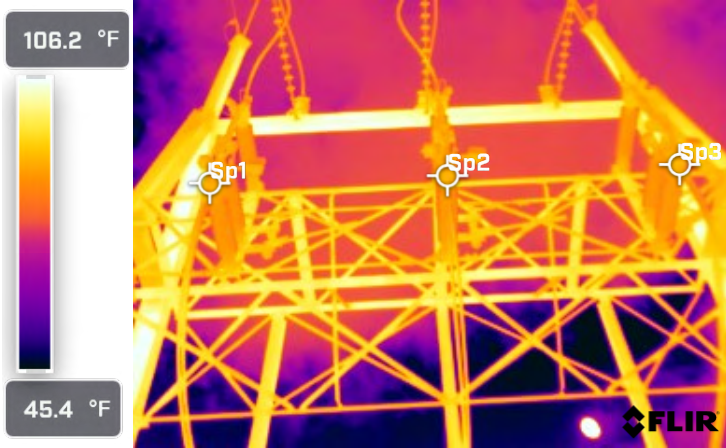

FLIR1881.jpg



79320978

Parameters

Emissivity	0.95
Distance	3.00 ft
Reflected temp.	32.0 °F
Atmospheric temp.	74.0 °F
Relative humidity	50.0%
Ext. optics temp.	68.0 °F
Ext. optics trans.	1.00

Measurements

Sp1	90.0 °F
Sp2	91.4 °F
Sp3	90.7 °F

File information

File name	FLIR1881.jpg
File size	1011 KB
Width	320
Height	240
Minimum temp.	44.2 °F
Maximum temp.	266.4 °F

Geolocation

Coordinates	27°52'12.6"N 81°49'31.0"W
Compass degrees	

Isotherms

Camera information

Camera model	FLIR T530
Lens	FOL10
Camera serial	79320978
Filter	
Range max.	248.0 °F
Range min.	-4.0 °F
Field of view	41.90

Text annotations



Orange Cogen
Test Report
2023 Outage Reports
Job #OCFL2310066



Empowering Electrical Infrastructure
for a Sustainable Future



Testing and Commissioning Services

6625 Network Way, Indianapolis, IN 46278

www.hva-inc.com/pc-field-services/

Equipment Tested: T1 & T2 Maintenance Scope of Work: Transformers, Breakers, and

Contactors

Observations and Recommendations:

52GT1 Brekaer: Damaged breaker parts sourced from spare. New parts are being sourced to replace.

52-1 Breaker: Found grounded charging motor. New parts are being sourced to replace.

Results: We were able to temporarily clear ground on charging motor on 52-1 and in-service

52GT1 breaker has been repaired.

2023 Outage Reports



Bolt was not in place for breaker to be racked out and closing latch to be in the up position



Wheels should be attached here, but broke off



All 4 wheels broken on breaker

Deficiency Summary
Job #OCFL2310066



PAGE _____

Customer Orange Cogen
Owner Orange Cogen

Site: Orange Cogen Page: _____
Substation: Switch-Yard Date: 10/6/2023
Equipment: 15kV Breakers
Equipment: 52GT1 Breaker

DEFICIENCIES: Wheels on breaker all broke - Replaced with ones from Spare Breaker

Site: Orange Cogen Page: _____
Substation: Switch-Yard Date: 9/28/2023
Equipment: 15kV Breakers
Equipment: 52STG Breaker

DEFICIENCIES: Open / Close interlock bolt was missing and held the lever down - Fixed

MEDIUM VOLTAGE VACUUM MOTOR STARTER TEST



CUSTOMER Orange Cogen PAGE _____
 ADDRESS 1901 S. Clear Springs Rd; Bartow FL 33830 DATE 10/2/2023
 OWNER Orange Cogen; 1901 S. Clear Springs Rd; Bartow FL 33830 JOB # OCFL2310066
 SITE Orange Cogen TEST STATUS _____ Pass
 SUBSTATION Main MCC ASSET ID 250 HP/020D130 Gas BSTR Compressor - 3
 EQUIPMENT 4160 Starters AMBIENT TEMPERATURE 70 °F HUMIDITY 61 %

NAMEPLATE DATA

MANUFACTURER Siemens SERIAL NO. RAL-71921-2FB-072994 TYPE AC Contactor -FM
 CATALOG NO. 93H3533034A3A STARTER SIZE 4800 FORM N/A
 SERIES 93H35 AC Contactor MAXIMUM VOLTAGE 5000 INT. RATING kA @ kV
 OPERATING VOLTAGE 4160 CONTROL VOLTAGE 125 Other _____
 MOTOR CONTROL CENTER SYSTEM VOLTAGE _____ STARTER IDENTIFICATION _____

OVERCURRENT PROTECTION DEVICES

CONTROL POWER FUSE: MFR. Gould Shawmut TYPE PT Fuse SIZE 4800 V -2E amps
 MAIN POWER FUSE: MFR. Gould Shawmut - Amp-Trap TYPE Current Limiting Fuse SIZE 2400/4800V - 225 amps
 OVERLOAD PROTECTION: _____ TYPE _____ TESTED YES NO

INSTRUMENT TRANSFORMER DATA

CONTROL POWER TRANSFORMER: MFR. Siemens Energy VA RATING 115 TYPE CPT VOLTAGE 4000
 CURRENT TRANSFORMER: MFR. _____ RATIO :5 TYPE _____ CAT. NO. _____

Description	INSPECTED	CONDITION	CLEAN/LUBE
OVERALL CLEANLINESS	<input checked="" type="checkbox"/>	Good	
INSULATING MEMBERS	<input checked="" type="checkbox"/>	Good	
MECHANICAL CONNECTIONS	<input checked="" type="checkbox"/>	Good	
STRUCTURAL MEMBERS	<input checked="" type="checkbox"/>	Good	
CUBICLE	<input checked="" type="checkbox"/>	Good	
RACKING DEVICES	<input checked="" type="checkbox"/>	Good	
SHUTTER	<input checked="" type="checkbox"/>	Good	

Description	INSPECTED	CONDITION	CLEAN/LUBE
OPERATING MECHANISM	<input checked="" type="checkbox"/>	Good	
CONTACT FINGERS	<input checked="" type="checkbox"/>	Good	
VACUUM INTERRUPTER	<input checked="" type="checkbox"/>	Good	
CONTACT EROSION INDICATOR	<input checked="" type="checkbox"/>	Good	
CONTACT SEQUENCE	<input checked="" type="checkbox"/>	Good	
GROUND CONNECTIONS	<input checked="" type="checkbox"/>	Good	
AUXILIARY DEVICES	<input checked="" type="checkbox"/>	Good	

TEMPERATURE CORRECTION FACTOR TO: 20°C 40°C
 INSULATION TEST VOLTAGE 5000 KVDC TEST VOLTAGE MULTIPLIER, K1 = _____ K2 = (K1) (TCF)
 EQUIPMENT TEMPERATURE 20 °C TEMPERATURE CORRECTION FACTOR TO 20°C, TCF 1
 MILLIWATT LOSS TEST VOLTAGE _____ KVDC HIGH POTENTIAL TEST VOLTAGE _____ KVDC 12,000 KVAC

INSULATION TESTS	POLE 1	POLE 2	POLE 3
	READING	READING	READING
POLE TO POLE - CLOSED	6.92 T	5.40 T	8.12 T
POLE TO FRAME - CLOSED	3.92 T	8.54 T	3.99 T
LINE TO FRAME - OPEN	7.12 T	6.75 T	4.99 T
LOAD TO FRAME - OPEN	1.33 T	3.46 T	3.87 T
LINE TO LOAD - OPEN	2.01 T	6.01 T	8.51 T

CONTACT MEASUREMENTS

	POLE 1	POLE 2	POLE 3
POLE RESISTANCE	RDG. 105	100	111
MICRO - OHMS			
MAIN FUSE	RDG. 0.5	0.5	0.4
CPT - FUSE	20°C 0.8	0.8	

CONTROL WIRING - MEGOHMS				
READING		20°C		
		POLE 1	POLE 2	POLE 3
HIPOT - OPEN	AC	4.0	4.0	4.0
HIPOT - CLOSED	AC	4.0	4.0	4.2

MEDIUM VOLTAGE VACUUM MOTOR STARTER TEST



PAGE _____

COMMENTS:

DEFICIENCIES:

EQUIPMENT USED

#	Manufacturer	Model	Serial / ID Number	Type	Calibration Date	Calibration Due
1	FLUKE	FLUKE - 87V	38210208	MULTIMETER	1/14/2023	1/14/2024
2	MEGGER	10 kv	102311999	INSULATION	1/10/2023	1/10/2024
3	MEGGER	1006-603	102305978	DLRO10HD	1/14/2023	1/14/2024
4	HVI	50kV AC HIPOT	2534	AC - HIPOT	1/8/2023	1/8/2024

MEDIUM VOLTAGE VACUUM MOTOR STARTER TEST



CUSTOMER Orange Cogen PAGE _____
 ADDRESS 1901 S. Clear Springs Rd; Bartow FL 33830 DATE 10/2/2023
 OWNER Orange Cogen; 1901 S. Clear Springs Rd; Bartow FL 33830 JOB # OCFL2310066
 SITE Orange Cogen TEST STATUS _____ Pass _____
 SUBSTATION Main MCC ASSET ID 1500 HP/020D420 Electric Chiller-2
 EQUIPMENT 4160 Starters AMBIENT TEMPERATURE 70 °F HUMIDITY 61 %

NAMEPLATE DATA

MANUFACTURER Siemens SERIAL NO. RAL-71921-2RC-072694 TYPE AC Contactor -FM
 CATALOG NO. 93H3533034A3A STARTER SIZE 4800 FORM N/A
 SERIES 93H35 AC Contactor MAXIMUM VOLTAGE 5000 INT. RATING _____ kA @ _____ kV
 OPERATING VOLTAGE 4160 CONTROL VOLTAGE 125 Other _____
 MOTOR CONTROL CENTER SYSTEM VOLTAGE _____ STARTER IDENTIFICATION _____

OVERCURRENT PROTECTION DEVICES

CONTROL POWER FUSE: MFR. Gould Shawmut TYPE PT Fuse SIZE 4800 V -2E amps
 MAIN POWER FUSE: MFR. Gould Shawmut - Amp-Trap TYPE Current Limiting Fuse SIZE 2400/4800V - 225 amps
 OVERLOAD PROTECTION: _____ TYPE _____ TESTED YES NO

INSTRUMENT TRANSFORMER DATA

CONTROL POWER TRANSFORMER: MFR. Siemens Energy VA RATING 115 TYPE CPT VOLTAGE 4000
 CURRENT TRANSFORMER: MFR. _____ RATIO :5 TYPE _____ CAT. NO. _____

Description	INSPECTED	CONDITION	CLEAN/LUBE
OVERALL CLEANLINESS	<input checked="" type="checkbox"/>	Good	
INSULATING MEMBERS	<input checked="" type="checkbox"/>	Good	
MECHANICAL CONNECTIONS	<input checked="" type="checkbox"/>	Good	
STRUCTURAL MEMBERS	<input checked="" type="checkbox"/>	Good	
CUBICLE	<input checked="" type="checkbox"/>	Good	
RACKING DEVICES	<input checked="" type="checkbox"/>	Good	
SHUTTER	<input checked="" type="checkbox"/>	Good	

Description	INSPECTED	CONDITION	CLEAN/LUBE
OPERATING MECHANISM	<input checked="" type="checkbox"/>	Good	
CONTACT FINGERS	<input checked="" type="checkbox"/>	Good	
VACUUM INTERRUPTER	<input checked="" type="checkbox"/>	Good	
CONTACT EROSION INDICATOR	<input checked="" type="checkbox"/>	Good	
CONTACT SEQUENCE	<input checked="" type="checkbox"/>	Good	
GROUND CONNECTIONS	<input checked="" type="checkbox"/>	Good	
AUXILIARY DEVICES	<input checked="" type="checkbox"/>	Good	

TEMPERATURE CORRECTION FACTOR TO: 20°C 40°C
 INSULATION TEST VOLTAGE 5000 KVDC TEST VOLTAGE MULTIPLIER, K1 = _____ K2 = (K1) (TCF)
 EQUIPMENT TEMPERATURE 20 °C TEMPERATURE CORRECTION FACTOR TO 20°C, TCF 1
 MILLIWATT LOSS TEST VOLTAGE _____ KVDC HIGH POTENTIAL TEST VOLTAGE _____ KVDC 12,000 KVAC

INSULATION TESTS	POLE 1	POLE 2	POLE 3
	READING	READING	READING
POLE TO POLE - CLOSED	1.42 T	2.06 T	1.94 T
POLE TO FRAME - CLOSED	1.17 T	1.65 T	1.83 T
LINE TO FRAME - OPEN	1.14 T	1.44 T	1.49 T
LOAD TO FRAME - OPEN	1.33 T	1.39 T	1.28 T
LINE TO LOAD - OPEN	1.30 T	1.46 T	1.60 T

CONTACT MEASUREMENTS

	POLE 1	POLE 2	POLE 3
POLE RESISTANCE	RDG. 94	100	130
MICRO - OHMS			
MAIN FUSE	RDG. 1.4	1.9	1.9
CPT - FUSE	20°C 1.4	1.3	

CONTROL WIRING - MEGOHMS			
READING		20°C	

		POLE 1	POLE 2	POLE 3
HIPOT - OPEN	AC	3.8	4.0	4.0
HIPOT - CLOSED	AC	4.0	3.8	4.0

TESTED BY: Matthew Falchetti / Andrew Kirk

MEDIUM VOLTAGE VACUUM MOTOR STARTER TEST



PAGE _____

COMMENTS:

DEFICIENCIES:

EQUIPMENT USED

#	Manufacturer	Model	Serial / ID Number	Type	Calibration Date	Calibration Due
1	FLUKE	FLUKE - 87V	38210208	MULTIMETER	1/14/2023	1/14/2024
2	MEGGER	10 kv	102311999	INSULATION	1/10/2023	1/10/2024
3	MEGGER	1006-603	102305978	DLRO10HD	1/14/2023	1/14/2024
4	HVI	50kV AC HIPOT	2534	AC - HIPOT	1/8/2023	1/8/2024

MEDIUM VOLTAGE VACUUM MOTOR STARTER TEST



CUSTOMER Orange Cogen PAGE _____
 ADDRESS 1901 S. Clear Springs Rd; Bartow FL 33830 DATE 10/2/2023
 OWNER Orange Cogen; 1901 S. Clear Springs Rd; Bartow FL 33830 JOB # OCFL2310066
 SITE Orange Cogen TEST STATUS _____ Pass _____
 SUBSTATION Main MCC ASSET ID 250 HP 006D630 Feedwater Pump - 3
 EQUIPMENT 4160 Starters AMBIENT TEMPERATURE 70 °F HUMIDITY 61 %

NAMEPLATE DATA

MANUFACTURER Siemens SERIAL NO. RAL-71921-10FC-072894 TYPE AC Contactor -FM
 CATALOG NO. 93H3533034A3A STARTER SIZE 4800 FORM N/A
 SERIES 93H35 AC Contactor MAXIMUM VOLTAGE 5000 INT. RATING kA @ kV
 OPERATING VOLTAGE 4160 CONTROL VOLTAGE 125 Other _____
 MOTOR CONTROL CENTER SYSTEM VOLTAGE _____ STARTER IDENTIFICATION _____

OVERCURRENT PROTECTION DEVICES

CONTROL POWER FUSE: MFR. Gould Shawmut TYPE PT Fuse SIZE 4800 V -2E amps
 MAIN POWER FUSE: MFR. Gould Shawmut - Amp-Trap TYPE Current Limiting Fuse SIZE 2400/4800V - 225 amps
 OVERLOAD PROTECTION: _____ TYPE _____ TESTED YES NO

INSTRUMENT TRANSFORMER DATA

CONTROL POWER TRANSFORMER: MFR. Siemens Energy VA RATING 115 TYPE CPT VOLTAGE 4000
 CURRENT TRANSFORMER: MFR. _____ RATIO :5 TYPE _____ CAT. NO. _____

Description	INSPECTED	CONDITION	CLEAN/LUBE
OVERALL CLEANLINESS	✓	Good	
INSULATING MEMBERS	✓	Good	
MECHANICAL CONNECTIONS	✓	Good	
STRUCTURAL MEMBERS	✓	Good	
CUBICLE	✓	Good	
RACKING DEVICES	✓	Good	
SHUTTER	✓	Good	

Description	INSPECTED	CONDITION	CLEAN/LUBE
OPERATING MECHANISM	✓	Good	
CONTACT FINGERS	✓	Good	
VACUUM INTERRUPTER	✓	Good	
CONTACT EROSION INDICATOR	✓	Good	
CONTACT SEQUENCE	✓	Good	
GROUND CONNECTIONS	✓	Good	
AUXILIARY DEVICES	✓	Good	

TEMPERATURE CORRECTION FACTOR TO: 20°C 40°C
 INSULATION TEST VOLTAGE 5000 KVDC TEST VOLTAGE MULTIPLIER, K1 = _____ K2 = (K1) (TCF)
 EQUIPMENT TEMPERATURE 20 °C TEMPERATURE CORRECTION FACTOR TO 20°C, TCF 1
 MILLIWATT LOSS TEST VOLTAGE _____ KVDC HIGH POTENTIAL TEST VOLTAGE _____ KVDC 12,000 KVAC

INSULATION TESTS	POLE 1	POLE 2	POLE 3
	READING	READING	READING
POLE TO POLE - CLOSED	6.33 T	6.52 T	6.73 T
POLE TO FRAME - CLOSED	4.90 T	3.20 T	7.34 T
LINE TO FRAME - OPEN	8.17 T	6.85 T	7.01 T
LOAD TO FRAME - OPEN	1.95 T	1.78 T	1.59 T
LINE TO LOAD - OPEN	8.99 T	10.38 T	11.9 T

CONTACT MEASUREMENTS

	POLE 1	POLE 2	POLE 3
POLE RESISTANCE	RDG. 99	100	101
MICRO - OHMS			
MAIN FUSE	RDG. 0.9	0.9	1.1
CPT - FUSE	20°C 1.2	1.2	

CONTROL WIRING - MEGOHMS			
READING		20°C	

		POLE 1	POLE 2	POLE 3
HIPOT - OPEN	AC	3.8	4.0	4.0
HIPOT - CLOSED	AC	4.0	4.0	4.0

TESTED BY: Matthew Falchetti / Andrew Kirk

MEDIUM VOLTAGE VACUUM MOTOR STARTER TEST



PAGE _____

COMMENTS:

DEFICIENCIES:

EQUIPMENT USED

#	Manufacturer	Model	Serial / ID Number	Type	Calibration Date	Calibration Due
1	FLUKE	FLUKE - 87V	38210208	MULTIMETER	1/14/2023	1/14/2024
2	MEGGER	10 kv	102311999	INSULATION	1/10/2023	1/10/2024
3	MEGGER	1006-603	102305978	DLRO10HD	1/14/2023	1/14/2024
4	HVI	50kV AC HIPOT	2534	AC - HIPOT	1/8/2023	1/8/2024

MEDIUM VOLTAGE VACUUM MOTOR STARTER TEST



CUSTOMER Orange Cogen PAGE _____
 ADDRESS 1901 S. Clear Springs Rd; Bartow FL 33830 DATE 10/2/2023
 OWNER Orange Cogen; 1901 S. Clear Springs Rd; Bartow FL 33830 JOB # OCFL2310066
 SITE Orange Cogen TEST STATUS _____ Pass _____
 SUBSTATION Main MCC ASSET ID 1500 HP/020D410 Electric Chiller-1
 EQUIPMENT 4160 Starters AMBIENT TEMPERATURE 70 °F HUMIDITY 61 %

NAMEPLATE DATA

MANUFACTURER Siemens SERIAL NO. RAL-71921-11RB-072994 TYPE AC Contactor -FM
 CATALOG NO. 93H3533034A3A STARTER SIZE 4800 FORM N/A
 SERIES 93H35 AC Contactor MAXIMUM VOLTAGE 5000 INT. RATING kA @ kV
 OPERATING VOLTAGE 4160 CONTROL VOLTAGE 125 Other _____
 MOTOR CONTROL CENTER SYSTEM VOLTAGE _____ STARTER IDENTIFICATION _____

OVERCURRENT PROTECTION DEVICES

CONTROL POWER FUSE: MFR. Gould Shawmut TYPE PT Fuse SIZE 4800 V -2E amps
 MAIN POWER FUSE: MFR. Gould Shawmut - Amp-Trap TYPE Current Limiting Fuse SIZE 2400/4800V - 225 amps
 OVERLOAD PROTECTION: _____ TYPE _____ TESTED YES NO

INSTRUMENT TRANSFORMER DATA

CONTROL POWER TRANSFORMER: MFR. Siemens Energy VA RATING 115 TYPE CPT VOLTAGE 4000
 CURRENT TRANSFORMER: MFR. _____ RATIO :5 TYPE _____ CAT. NO. _____

Description	INSPECTED	CONDITION	CLEAN/LUBE
OVERALL CLEANLINESS	<input checked="" type="checkbox"/>	Good	
INSULATING MEMBERS	<input checked="" type="checkbox"/>	Good	
MECHANICAL CONNECTIONS	<input checked="" type="checkbox"/>	Good	
STRUCTURAL MEMBERS	<input checked="" type="checkbox"/>	Good	
CUBICLE	<input checked="" type="checkbox"/>	Good	
RACKING DEVICES	<input checked="" type="checkbox"/>	Good	
SHUTTER	<input checked="" type="checkbox"/>	Good	

Description	INSPECTED	CONDITION	CLEAN/LUBE
OPERATING MECHANISM	<input checked="" type="checkbox"/>	Good	
CONTACT FINGERS	<input checked="" type="checkbox"/>	Good	
VACUUM INTERRUPTER	<input checked="" type="checkbox"/>	Good	
CONTACT EROSION INDICATOR	<input checked="" type="checkbox"/>	Good	
CONTACT SEQUENCE	<input checked="" type="checkbox"/>	Good	
GROUND CONNECTIONS	<input checked="" type="checkbox"/>	Good	
AUXILIARY DEVICES	<input checked="" type="checkbox"/>	Good	

TEMPERATURE CORRECTION FACTOR TO: 20°C 40°C
 INSULATION TEST VOLTAGE 5000 KVDC TEST VOLTAGE MULTIPLIER, K1 = _____ K2 = (K1) (TCF)
 EQUIPMENT TEMPERATURE 20 °C TEMPERATURE CORRECTION FACTOR TO 20°C, TCF 1
 MILLIWATT LOSS TEST VOLTAGE _____ KVDC HIGH POTENTIAL TEST VOLTAGE _____ KVDC 12,000 KVAC

INSULATION TESTS	POLE 1	POLE 2	POLE 3
	READING	READING	READING
POLE TO POLE - CLOSED	2.01 T	1.08 T	1.17 T
POLE TO FRAME - CLOSED	1.08 T	805 G	925 G
LINE TO FRAME - OPEN	1.05 T	1.26 T	856 G
LOAD TO FRAME - OPEN	2.15 T	1.04 T	1.17 T
LINE TO LOAD - OPEN	786 G	1.21 T	1.37 T

CONTACT MEASUREMENTS

	POLE 1	POLE 2	POLE 3
POLE RESISTANCE	RDG. 88	105	97
MICRO - OHMS			
MAIN FUSE	RDG. 0.8	0.7	0.7
CPT - FUSE	20°C 1.2	1.6	

CONTROL WIRING - MEGOHMS			
READING		20°C	

		POLE 1	POLE 2	POLE 3
HIPOT - OPEN	AC	4.0	3.8	4.2
HIPOT - CLOSED	AC	4.2	4.0	4.2

TESTED BY: Matthew Falchetti / Andrew Kirk

MEDIUM VOLTAGE VACUUM MOTOR STARTER TEST



PAGE _____

COMMENTS:

DEFICIENCIES:

EQUIPMENT USED

#	Manufacturer	Model	Serial / ID Number	Type	Calibration Date	Calibration Due
1	FLUKE	FLUKE - 87V	38210208	MULTIMETER	1/14/2023	1/14/2024
2	MEGGER	10 kv	102311999	INSULATION	1/10/2023	1/10/2024
3	MEGGER	1006-603	102305978	DLRO10HD	1/14/2023	1/14/2024
4	HVI	50kV AC HIPOT	2534	AC - HIPOT	1/8/2023	1/8/2024

MEDIUM VOLTAGE VACUUM MOTOR STARTER TEST



CUSTOMER Orange Cogen PAGE _____
 ADDRESS 1901 S. Clear Springs Rd; Bartow FL 33830 DATE 10/2/2023
 OWNER Orange Cogen; 1901 S. Clear Springs Rd; Bartow FL 33830 JOB # OCFL2310066
 SITE Orange Cogen TEST STATUS _____ Pass
 SUBSTATION Main MCC ASSET ID 1500 HP/020D430 Electric Chiller-3
 EQUIPMENT 4160 Starters AMBIENT TEMPERATURE 70 °F HUMIDITY 61 %

NAMEPLATE DATA

MANUFACTURER Siemens SERIAL NO. RAL-71921-11RC-072894 TYPE AC Contactor -FM
 CATALOG NO. 93H3533034A3A STARTER SIZE 4800 FORM N/A
 SERIES 93H35 AC Contactor MAXIMUM VOLTAGE 5000 INT. RATING kA @ kV
 OPERATING VOLTAGE 4160 CONTROL VOLTAGE 125 Other _____
 MOTOR CONTROL CENTER SYSTEM VOLTAGE _____ STARTER IDENTIFICATION _____

OVERCURRENT PROTECTION DEVICES

CONTROL POWER FUSE: MFR. Gould Shawmut TYPE PT Fuse SIZE 4800 V -2E amps
 MAIN POWER FUSE: MFR. Gould Shawmut - Amp-Trap TYPE Current Limiting Fuse SIZE 2400/4800V - 225 amps
 OVERLOAD PROTECTION: _____ TYPE _____ TESTED YES NO

INSTRUMENT TRANSFORMER DATA

CONTROL POWER TRANSFORMER: MFR. Siemens Energy VA RATING 115 TYPE CPT VOLTAGE 4000
 CURRENT TRANSFORMER: MFR. _____ RATIO :5 TYPE _____ CAT. NO. _____

Description	INSPECTED	CONDITION	CLEAN/LUBE
OVERALL CLEANLINESS	✓	Good	
INSULATING MEMBERS	✓	Good	
MECHANICAL CONNECTIONS	✓	Good	
STRUCTURAL MEMBERS	✓	Good	
CUBICLE	✓	Good	
RACKING DEVICES	✓	Good	
SHUTTER	✓	Good	

Description	INSPECTED	CONDITION	CLEAN/LUBE
OPERATING MECHANISM	✓	Good	
CONTACT FINGERS	✓	Good	
VACUUM INTERRUPTER	✓	Good	
CONTACT EROSION INDICATOR	✓	Good	
CONTACT SEQUENCE	✓	Good	
GROUND CONNECTIONS	✓	Good	
AUXILIARY DEVICES	✓	Good	

TEMPERATURE CORRECTION FACTOR TO: 20°C 40°C
 INSULATION TEST VOLTAGE 5000 KVDC TEST VOLTAGE MULTIPLIER, K1 = _____ K2 = (K1) (TCF)
 EQUIPMENT TEMPERATURE 20 °C TEMPERATURE CORRECTION FACTOR TO 20°C, TCF 1
 MILLIWATT LOSS TEST VOLTAGE _____ KVDC HIGH POTENTIAL TEST VOLTAGE _____ KVDC 12,000 KVAC

INSULATION TESTS	POLE 1	POLE 2	POLE 3
	READING	READING	READING
POLE TO POLE - CLOSED	2.84 T	1.36 T	2.43 T
POLE TO FRAME - CLOSED	1.21 T	1.26 T	1.45 T
LINE TO FRAME - OPEN	2.20 T	1.80 T	1.18 T
LOAD TO FRAME - OPEN	2.02 T	2.08 T	1.14 T
LINE TO LOAD - OPEN	2.21 T	825 G	1.60 T

CONTACT MEASUREMENTS

	POLE 1	POLE 2	POLE 3
POLE RESISTANCE	RDG. 91	112	96
MICRO - OHMS			
MAIN FUSE	RDG. 0.4	0.3	0.3
CPT - FUSE	20°C 0.7	0.7	

CONTROL WIRING - MEGOHMS			
READING		20°C	

		POLE 1	POLE 2	POLE 3
HIPOT - OPEN	AC	4.0	4.0	4.0
HIPOT - CLOSED	AC	4.0	4.0	4.0

TESTED BY: Matthew Falchetti / Andrew Kirk

MEDIUM VOLTAGE VACUUM MOTOR STARTER TEST



PAGE _____

COMMENTS:

DEFICIENCIES:

EQUIPMENT USED

#	Manufacturer	Model	Serial / ID Number	Type	Calibration Date	Calibration Due
1	FLUKE	FLUKE - 87V	38210208	MULTIMETER	1/14/2023	1/14/2024
2	MEGGER	10 kv	102311999	INSULATION	1/10/2023	1/10/2024
3	MEGGER	1006-603	102305978	DLRO10HD	1/14/2023	1/14/2024
4	HVI	50kV AC HIPOT	2534	AC - HIPOT	1/8/2023	1/8/2024

MEDIUM VOLTAGE VACUUM MOTOR STARTER TEST



CUSTOMER Orange Cogen PAGE _____
 ADDRESS 1901 S. Clear Springs Rd; Bartow FL 33830 DATE 10/2/2023
 OWNER Orange Cogen; 1901 S. Clear Springs Rd; Bartow FL 33830 JOB # OCFL2310066
 SITE Orange Cogen TEST STATUS _____ Pass
 SUBSTATION Main MCC ASSET ID 250 HP/020D120 Gas BSTR Compressor - 2
 EQUIPMENT 4160 Starters AMBIENT TEMPERATURE 70 °F HUMIDITY 61 %

NAMEPLATE DATA

MANUFACTURER Siemens SERIAL NO. RAL-71921-11FC-072894 TYPE AC Contactor -FM
 CATALOG NO. 93H3533034A3A STARTER SIZE 4800 FORM N/A
 SERIES 93H35 AC Contactor MAXIMUM VOLTAGE 5000 INT. RATING kA @ kV
 OPERATING VOLTAGE 4160 CONTROL VOLTAGE 125 Other _____
 MOTOR CONTROL CENTER SYSTEM VOLTAGE _____ STARTER IDENTIFICATION _____

OVERCURRENT PROTECTION DEVICES

CONTROL POWER FUSE: MFR. Gould Shawmut TYPE PT Fuse SIZE 4800 V -2E amps
 MAIN POWER FUSE: MFR. Gould Shawmut - Amp-Trap TYPE Current Limiting Fuse SIZE 2400/4800V - 225 amps
 OVERLOAD PROTECTION: _____ TYPE _____ TESTED YES NO

INSTRUMENT TRANSFORMER DATA

CONTROL POWER TRANSFORMER: MFR. Siemens Energy VA RATING 115 TYPE CPT VOLTAGE 4000
 CURRENT TRANSFORMER: MFR. _____ RATIO :5 TYPE _____ CAT. NO. _____

Description	INSPECTED	CONDITION	CLEAN/LUBE
OVERALL CLEANLINESS	✓	Good	
INSULATING MEMBERS	✓	Good	
MECHANICAL CONNECTIONS	✓	Good	
STRUCTURAL MEMBERS	✓	Good	
CUBICLE	✓	Good	
RACKING DEVICES	✓	Good	
SHUTTER	✓	Good	

Description	INSPECTED	CONDITION	CLEAN/LUBE
OPERATING MECHANISM	✓	Good	
CONTACT FINGERS	✓	Good	
VACUUM INTERRUPTER	✓	Good	
CONTACT EROSION INDICATOR	✓	Good	
CONTACT SEQUENCE	✓	Good	
GROUND CONNECTIONS	✓	Good	
AUXILIARY DEVICES	✓	Good	

TEMPERATURE CORRECTION FACTOR TO: 20°C 40°C
 INSULATION TEST VOLTAGE 5000 KVDC TEST VOLTAGE MULTIPLIER, K1 = _____ K2 = (K1) (TCF)
 EQUIPMENT TEMPERATURE 20 °C TEMPERATURE CORRECTION FACTOR TO 20°C, TCF 1
 MILLIWATT LOSS TEST VOLTAGE _____ KVDC HIGH POTENTIAL TEST VOLTAGE _____ KVDC 12,000 KVAC

INSULATION TESTS	POLE 1	POLE 2	POLE 3
	READING	READING	READING
POLE TO POLE - CLOSED	1.02 T	1.23 T	1.41 T
POLE TO FRAME - CLOSED	470 G	578 G	609 G
LINE TO FRAME - OPEN	4.25 T	2.74 T	3.98 T
LOAD TO FRAME - OPEN	2.84 T	3.04 T	2.45 T
LINE TO LOAD - OPEN	281 G	4.26 T	4.42 T

CONTACT MEASUREMENTS

	POLE 1	POLE 2	POLE 3
POLE RESISTANCE	RDG. 92	96	100
MICRO - OHMS			
MAIN FUSE	RDG. 0.5	0.6	0.6
CPT - FUSE	20°C 1.4	1.4	

CONTROL WIRING - MEGOHMS			
READING		20°C	

		POLE 1	POLE 2	POLE 3
HIPOT - OPEN	AC	4.0	3.8	3.8
HIPOT - CLOSED	AC	4.0	4.0	4.0

TESTED BY: Matthew Falchetti / Andrew Kirk

MEDIUM VOLTAGE VACUUM MOTOR STARTER TEST



PAGE _____

COMMENTS:

DEFICIENCIES:

EQUIPMENT USED

#	Manufacturer	Model	Serial / ID Number	Type	Calibration Date	Calibration Due
1	FLUKE	FLUKE - 87V	38210208	MULTIMETER	1/14/2023	1/14/2024
2	MEGGER	10 kv	102311999	INSULATION	1/10/2023	1/10/2024
3	MEGGER	1006-603	102305978	DLRO10HD	1/14/2023	1/14/2024
4	HVI	50kV AC HIPOT	2534	AC - HIPOT	1/8/2023	1/8/2024

MEDIUM VOLTAGE VACUUM MOTOR STARTER TEST



CUSTOMER Orange Cogen PAGE _____
 ADDRESS 1901 S. Clear Springs Rd; Bartow FL 33830 DATE 10/2/2023
 OWNER Orange Cogen; 1901 S. Clear Springs Rd; Bartow FL 33830 JOB # OCFL2310066
 SITE Orange Cogen TEST STATUS _____ Pass
 SUBSTATION Main MCC ASSET ID 350 HP/013D140 Primary Circ Water Pump - 2
 EQUIPMENT 4160 Starters AMBIENT TEMPERATURE 70 °F HUMIDITY 61 %

NAMEPLATE DATA

MANUFACTURER Siemens SERIAL NO. RAL-71921-2FC-072994 TYPE AC Contactor -FM
 CATALOG NO. 93H3533034A3A STARTER SIZE 4800 FORM N/A
 SERIES 93H35 AC Contactor MAXIMUM VOLTAGE 5000 INT. RATING kA @ kV
 OPERATING VOLTAGE 4160 CONTROL VOLTAGE 125 Other _____
 MOTOR CONTROL CENTER SYSTEM VOLTAGE _____ STARTER IDENTIFICATION _____

OVERCURRENT PROTECTION DEVICES

CONTROL POWER FUSE: MFR. Gould Shawmut TYPE PT Fuse SIZE 4800 V -2E amps
 MAIN POWER FUSE: MFR. Gould Shawmut - Amp-Trap TYPE Current Limiting Fuse SIZE 2400/4800V - 225 amps
 OVERLOAD PROTECTION: _____ TYPE _____ TESTED YES NO

INSTRUMENT TRANSFORMER DATA

CONTROL POWER TRANSFORMER: MFR. Siemens Energy VA RATING 115 TYPE CPT VOLTAGE 4000
 CURRENT TRANSFORMER: MFR. _____ RATIO :5 TYPE _____ CAT. NO. _____

Description	INSPECTED	CONDITION	CLEAN/LUBE
OVERALL CLEANLINESS	<input checked="" type="checkbox"/>	Good	
INSULATING MEMBERS	<input checked="" type="checkbox"/>	Good	
MECHANICAL CONNECTIONS	<input checked="" type="checkbox"/>	Good	
STRUCTURAL MEMBERS	<input checked="" type="checkbox"/>	Good	
CUBICLE	<input checked="" type="checkbox"/>	Good	
RACKING DEVICES	<input checked="" type="checkbox"/>	Good	
SHUTTER	<input checked="" type="checkbox"/>	Good	

Description	INSPECTED	CONDITION	CLEAN/LUBE
OPERATING MECHANISM	<input checked="" type="checkbox"/>	Good	
CONTACT FINGERS	<input checked="" type="checkbox"/>	Good	
VACUUM INTERRUPTER	<input checked="" type="checkbox"/>	Good	
CONTACT EROSION INDICATOR	<input checked="" type="checkbox"/>	Good	
CONTACT SEQUENCE	<input checked="" type="checkbox"/>	Good	
GROUND CONNECTIONS	<input checked="" type="checkbox"/>	Good	
AUXILIARY DEVICES	<input checked="" type="checkbox"/>	Good	

TEMPERATURE CORRECTION FACTOR TO: 20°C 40°C
 INSULATION TEST VOLTAGE 5000 KVDC TEST VOLTAGE MULTIPLIER, K1 = _____ K2 = (K1) (TCF)
 EQUIPMENT TEMPERATURE 20 °C TEMPERATURE CORRECTION FACTOR TO 20°C, TCF 1
 MILLIWATT LOSS TEST VOLTAGE _____ KVDC HIGH POTENTIAL TEST VOLTAGE _____ KVDC 12,000 KVAC

INSULATION TESTS	POLE 1	POLE 2	POLE 3
	READING	READING	READING
POLE TO POLE - CLOSED	12.71 T	11.18 T	10.45 T
POLE TO FRAME - CLOSED	5.27 T	3.40 T	
LINE TO FRAME - OPEN	7.64 T	5.57 T	3.94 T
LOAD TO FRAME - OPEN	4.49 T	6.82 T	4.55 T
LINE TO LOAD - OPEN	5.82 T	7.52 T	9.62 T

CONTACT MEASUREMENTS

	POLE 1	POLE 2	POLE 3
POLE RESISTANCE	RDG. 90	92	94
MICRO - OHMS			
MAIN FUSE	RDG. 0.7	0.7	0.8
CPT - FUSE	20°C 1.1	1.3	

CONTROL WIRING - MEGOHMS				
READING		20°C		
			POLE 1	POLE 2
HIPOT - OPEN	AC	4.2	4.0	4.0
HIPOT - CLOSED	AC	3.8	3.8	3.8

MEDIUM VOLTAGE VACUUM MOTOR STARTER TEST



PAGE _____

COMMENTS:

DEFICIENCIES:

EQUIPMENT USED

#	Manufacturer	Model	Serial / ID Number	Type	Calibration Date	Calibration Due
1	FLUKE	FLUKE - 87V	38210208	MULTIMETER	1/14/2023	1/14/2024
2	MEGGER	10 kv	102311999	INSULATION	1/10/2023	1/10/2024
3	MEGGER	1006-603	102305978	DLRO10HD	1/14/2023	1/14/2024
4	HVI	50kV AC HIPOT	2534	AC - HIPOT	1/8/2023	1/8/2024

MEDIUM VOLTAGE VACUUM MOTOR STARTER TEST



CUSTOMER Orange Cogen PAGE _____
 ADDRESS 1901 S. Clear Springs Rd; Bartow FL 33830 DATE 10/2/2023
 OWNER Orange Cogen; 1901 S. Clear Springs Rd; Bartow FL 33830 JOB # OCFL2310066
 SITE Orange Cogen TEST STATUS _____ Pass
 SUBSTATION Main MCC ASSET ID 350 HP/013D130 Primary Circ- Water Pump -1
 EQUIPMENT 4160 Starters AMBIENT TEMPERATURE 70 °F HUMIDITY 61 %

NAMEPLATE DATA

MANUFACTURER Siemens SERIAL NO. RAL-71921-2RB-072894 TYPE AC Contactor -FM
 CATALOG NO. 93H3533034A3A STARTER SIZE 4800 FORM N/A
 SERIES 93H35 AC Contactor MAXIMUM VOLTAGE 5000 INT. RATING kA @ kV
 OPERATING VOLTAGE 4160 CONTROL VOLTAGE 125 Other _____
 MOTOR CONTROL CENTER SYSTEM VOLTAGE _____ STARTER IDENTIFICATION _____

OVERCURRENT PROTECTION DEVICES

CONTROL POWER FUSE: MFR. Gould Shawmut TYPE PT Fuse SIZE 4800 V -2E amps
 MAIN POWER FUSE: MFR. Gould Shawmut - Amp-Trap TYPE Current Limiting Fuse SIZE 2400/4800V - 225 amps
 OVERLOAD PROTECTION: _____ TYPE _____ TESTED YES NO

INSTRUMENT TRANSFORMER DATA

CONTROL POWER TRANSFORMER: MFR. Siemens Energy VA RATING 115 TYPE CPT VOLTAGE 4000
 CURRENT TRANSFORMER: MFR. _____ RATIO :5 TYPE _____ CAT. NO. _____

Description	INSPECTED	CONDITION	CLEAN/LUBE
OVERALL CLEANLINESS	<input checked="" type="checkbox"/>	Good	
INSULATING MEMBERS	<input checked="" type="checkbox"/>	Good	
MECHANICAL CONNECTIONS	<input checked="" type="checkbox"/>	Good	
STRUCTURAL MEMBERS	<input checked="" type="checkbox"/>	Good	
CUBICLE	<input checked="" type="checkbox"/>	Good	
RACKING DEVICES	<input checked="" type="checkbox"/>	Good	
SHUTTER	<input checked="" type="checkbox"/>	Good	

Description	INSPECTED	CONDITION	CLEAN/LUBE
OPERATING MECHANISM	<input checked="" type="checkbox"/>	Good	
CONTACT FINGERS	<input checked="" type="checkbox"/>	Good	
VACUUM INTERRUPTER	<input checked="" type="checkbox"/>	Good	
CONTACT EROSION INDICATOR	<input checked="" type="checkbox"/>	Good	
CONTACT SEQUENCE	<input checked="" type="checkbox"/>	Good	
GROUND CONNECTIONS	<input checked="" type="checkbox"/>	Good	
AUXILIARY DEVICES	<input checked="" type="checkbox"/>	Good	

TEMPERATURE CORRECTION FACTOR TO: 20°C 40°C
 INSULATION TEST VOLTAGE 5000 KVDC TEST VOLTAGE MULTIPLIER, K1 = _____ K2 = (K1) (TCF)
 EQUIPMENT TEMPERATURE 20 °C TEMPERATURE CORRECTION FACTOR TO 20°C, TCF 1
 MILLIWATT LOSS TEST VOLTAGE _____ KVDC HIGH POTENTIAL TEST VOLTAGE _____ KVDC 12,000 KVAC

INSULATION TESTS	POLE 1	POLE 2	POLE 3
	READING	READING	READING
POLE TO POLE - CLOSED	6.82 T	5.42 T	10.01 T
POLE TO FRAME - CLOSED	4.76 T	2.50 T	3.91 T
LINE TO FRAME - OPEN	4.88 T	8.64 T	5.69 T
LOAD TO FRAME - OPEN	1.64 T	4.41 T	1.47 T
LINE TO LOAD - OPEN	8.02 T	7.44 T	3.73 T

CONTACT MEASUREMENTS

	POLE 1	POLE 2	POLE 3
POLE RESISTANCE	RDG. 110	RDG. 115	RDG. 120
MICRO - OHMS			
MAIN FUSE	RDG. 0.7	RDG. 0.8	RDG. 0.8
CPT - FUSE	20°C 1.6	20°C 1.6	

CONTROL WIRING - MEGOHMS			
READING		20°C	

		POLE 1	POLE 2	POLE 3
HIPOT - OPEN	AC	4.0	4.2	4.2
HIPOT - CLOSED	AC	4.0	4.0	4.2

TESTED BY: Matthew Falchetti / Andrew Kirk

MEDIUM VOLTAGE VACUUM MOTOR STARTER TEST



PAGE _____

COMMENTS:

DEFICIENCIES:

EQUIPMENT USED:

#	Manufacturer	Model	Serial / ID Number	Type	Calibration Date	Calibration Due
1	FLUKE	FLUKE - 87V	38210208	MULTIMETER	1/14/2023	1/14/2024
2	MEGGER	10 kv	102311999	INSULATION	1/10/2023	1/10/2024
3	MEGGER	1006-603	102305978	DLRO10HD	1/14/2023	1/14/2024
4	HVI	50kV AC HIPOT	2534	AC - HIPOT	1/8/2023	1/8/2024

MEDIUM VOLTAGE VACUUM MOTOR STARTER TEST



CUSTOMER Orange Cogen PAGE _____
 ADDRESS 1901 S. Clear Springs Rd; Bartow FL 33830 DATE 10/2/2023
 OWNER Orange Cogen; 1901 S. Clear Springs Rd; Bartow FL 33830 JOB # OCFL2310066
 SITE Orange Cogen TEST STATUS _____ Pass _____
 SUBSTATION Main MCC ASSET ID 250 HP 006D620 Feedwater Pump - 1
 EQUIPMENT 4160 Starters AMBIENT TEMPERATURE 70 °F HUMIDITY 61 %

NAMEPLATE DATA

MANUFACTURER Siemens SERIAL NO. RAL-71921-1FB-072994 TYPE AC Contactor -FM
 CATALOG NO. 93H3533034A3A STARTER SIZE 4800 FORM N/A
 SERIES 93H35 AC Contactor MAXIMUM VOLTAGE 5000 INT. RATING kA @ kV
 OPERATING VOLTAGE 4160 CONTROL VOLTAGE 125 Other _____
 MOTOR CONTROL CENTER SYSTEM VOLTAGE _____ STARTER IDENTIFICATION _____

OVERCURRENT PROTECTION DEVICES

CONTROL POWER FUSE: MFR. Gould Shawmut TYPE PT Fuse SIZE 4800 V -2E amps
 MAIN POWER FUSE: MFR. Gould Shawmut - Amp-Trap TYPE Current Limiting Fuse SIZE 2400/4800V - 225 amps
 OVERLOAD PROTECTION: _____ TYPE _____ TESTED YES NO

INSTRUMENT TRANSFORMER DATA

CONTROL POWER TRANSFORMER: MFR. Siemens Energy VA RATING 115 TYPE CPT VOLTAGE 4000
 CURRENT TRANSFORMER: MFR. _____ RATIO :5 TYPE _____ CAT. NO. _____

Description	INSPECTED	CONDITION	CLEAN/LUBE
OVERALL CLEANLINESS	✓	Good	
INSULATING MEMBERS	✓	Good	
MECHANICAL CONNECTIONS	✓	Good	
STRUCTURAL MEMBERS	✓	Good	
CUBICLE	✓	Good	
RACKING DEVICES	✓	Good	
SHUTTER	✓	Good	

Description	INSPECTED	CONDITION	CLEAN/LUBE
OPERATING MECHANISM	✓	Good	
CONTACT FINGERS	✓	Good	
VACUUM INTERRUPTER	✓	Good	
CONTACT EROSION INDICATOR	✓	Good	
CONTACT SEQUENCE	✓	Good	
GROUND CONNECTIONS	✓	Good	
AUXILIARY DEVICES	✓	Good	

TEMPERATURE CORRECTION FACTOR TO: 20°C 40°C
 INSULATION TEST VOLTAGE 5000 KVDC TEST VOLTAGE MULTIPLIER, K1 = _____ K2 = (K1) (TCF)
 EQUIPMENT TEMPERATURE 20 °C TEMPERATURE CORRECTION FACTOR TO 20°C, TCF 1
 MILLIWATT LOSS TEST VOLTAGE _____ KVDC HIGH POTENTIAL TEST VOLTAGE _____ KVDC 12,000 KVAC

INSULATION TESTS	POLE 1	POLE 2	POLE 3
	READING	READING	READING
POLE TO POLE - CLOSED	8.15 T	6.58 T	5.17 T
POLE TO FRAME - CLOSED	2.33 T	4.01 T	2.41 T
LINE TO FRAME - OPEN	2.99 T	6.83 T	7.16 T
LOAD TO FRAME - OPEN	2.07 T	4.94 T	2.72 T
LINE TO LOAD - OPEN	3.51 T	4.94 T	6.17 T

CONTACT MEASUREMENTS

	POLE 1	POLE 2	POLE 3
POLE RESISTANCE	RDG. 102	97	104
MICRO - OHMS			
MAIN FUSE	RDG. 0.5	0.6	0.7
CPT - FUSE	20°C 1.1	1.1	

CONTROL WIRING - MEGOHMS			
READING		20°C	

		POLE 1	POLE 2	POLE 3
HIPOT - OPEN	AC	4.0	4.0	4.0
HIPOT - CLOSED	AC	4.0	4.0	3.8

TESTED BY: Matthew Falchetti / Andrew Kirk

MEDIUM VOLTAGE VACUUM MOTOR STARTER TEST



PAGE _____

COMMENTS:

DEFICIENCIES:

EQUIPMENT USED

#	Manufacturer	Model	Serial / ID Number	Type	Calibration Date	Calibration Due
1	FLUKE	FLUKE - 87V	38210208	MULTIMETER	1/14/2023	1/14/2024
2	MEGGER	10 kv	102311999	INSULATION	1/10/2023	1/10/2024
3	MEGGER	1006-603	102305978	DLRO10HD	1/14/2023	1/14/2024
4	HVI	50kV AC HIPOT	2534	AC - HIPOT	1/8/2023	1/8/2024

MEDIUM VOLTAGE VACUUM MOTOR STARTER TEST



CUSTOMER Orange Cogen PAGE _____
 ADDRESS 1901 S. Clear Springs Rd; Bartow FL 33830 DATE 10/2/2023
 OWNER Orange Cogen; 1901 S. Clear Springs Rd; Bartow FL 33830 JOB # OCFL2310066
 SITE Orange Cogen TEST STATUS _____ Pass
 SUBSTATION Main MCC ASSET ID 250 HP 006D635 Feedwater Pump - 4
 EQUIPMENT 4160 Starters AMBIENT TEMPERATURE _____ °F HUMIDITY 61 %

NAMEPLATE DATA

MANUFACTURER Siemens SERIAL NO. RAL-71921-10FB-072894 TYPE AC Contactor -FM
 CATALOG NO. 93H3533034A3A STARTER SIZE 4800 FORM N/A
 SERIES 93H35 AC Contactor MAXIMUM VOLTAGE 5000 INT. RATING _____ kA @ _____ kV
 OPERATING VOLTAGE 4160 CONTROL VOLTAGE 125 Other _____
 MOTOR CONTROL CENTER SYSTEM VOLTAGE _____ STARTER IDENTIFICATION _____

OVERCURRENT PROTECTION DEVICES

CONTROL POWER FUSE: MFR. Gould Shawmut TYPE PT Fuse SIZE 4800 V -2E amps
 MAIN POWER FUSE: MFR. Gould Shawmut - Amp-Trap TYPE Current Limiting Fuse SIZE 2400/4800V - 225 amps
 OVERLOAD PROTECTION: _____ TYPE _____ TESTED YES NO

INSTRUMENT TRANSFORMER DATA

CONTROL POWER TRANSFORMER: MFR. Siemens Energy VA RATING 115 TYPE CPT VOLTAGE 4000
 CURRENT TRANSFORMER: MFR. _____ RATIO _____ :5 TYPE _____ CAT. NO. _____

Description	INSPECTED	CONDITION	CLEAN/LUBE
OVERALL CLEANLINESS	<input checked="" type="checkbox"/>	Good	
INSULATING MEMBERS	<input checked="" type="checkbox"/>	Good	
MECHANICAL CONNECTIONS	<input checked="" type="checkbox"/>	Good	
STRUCTURAL MEMBERS	<input checked="" type="checkbox"/>	Good	
CUBICLE	<input checked="" type="checkbox"/>	Good	
RACKING DEVICES	<input checked="" type="checkbox"/>	Good	
SHUTTER	<input checked="" type="checkbox"/>	Good	

Description	INSPECTED	CONDITION	CLEAN/LUBE
OPERATING MECHANISM	<input checked="" type="checkbox"/>	Good	
CONTACT FINGERS	<input checked="" type="checkbox"/>	Good	
VACUUM INTERRUPTER	<input checked="" type="checkbox"/>	Good	
CONTACT EROSION INDICATOR	<input checked="" type="checkbox"/>	Good	
CONTACT SEQUENCE	<input checked="" type="checkbox"/>	Good	
GROUND CONNECTIONS	<input checked="" type="checkbox"/>	Good	
AUXILIARY DEVICES	<input checked="" type="checkbox"/>	Good	

TEMPERATURE CORRECTION FACTOR TO: 20°C 40°C
 INSULATION TEST VOLTAGE 5000 KVDC TEST VOLTAGE MULTIPLIER, K1 = _____ K2 = (K1) (TCF)
 EQUIPMENT TEMPERATURE 20 °C TEMPERATURE CORRECTION FACTOR TO 20°C, TCF 1
 MILLIWATT LOSS TEST VOLTAGE _____ KVDC HIGH POTENTIAL TEST VOLTAGE _____ KVDC 12,000 KVAC

INSULATION TESTS	POLE 1	POLE 2	POLE 3
	READING	READING	READING
POLE TO POLE - CLOSED	4.62 T	4.75 T	5.13 T
POLE TO FRAME - CLOSED	2.19 T	1.75 T	1.35 T
LINE TO FRAME - OPEN	3.83 T	5.40 T	5.83 T
LOAD TO FRAME - OPEN	3.98 T	3.20 T	5.09 T
LINE TO LOAD - OPEN	774 G	1.20 T	4.51 T

CONTACT MEASUREMENTS

	POLE 1	POLE 2	POLE 3
POLE RESISTANCE	RDG. 90	97	102
MICRO - OHMS			
MAIN FUSE	RDG. 0.7	0.9	0.8
CPT - FUSE	20°C 1.3	1.3	

CONTROL WIRING - MEGOHMS			
READING		20°C	

		POLE 1	POLE 2	POLE 3
HIPOT - OPEN	AC	3.8	4.0	4.0
HIPOT - CLOSED	AC	4.0	4.0	4.0

TESTED BY: Matthew Falchetti / Andrew Kirk

MEDIUM VOLTAGE VACUUM MOTOR STARTER TEST



PAGE _____

COMMENTS:

DEFICIENCIES:

EQUIPMENT USED

#	Manufacturer	Model	Serial / ID Number	Type	Calibration Date	Calibration Due
1	FLUKE	FLUKE - 87V	38210208	MULTIMETER	1/14/2023	1/14/2024
2	MEGGER	10 kv	102311999	INSULATION	1/10/2023	1/10/2024
3	MEGGER	1006-603	102305978	DLRO10HD	1/14/2023	1/14/2024
4	HVI	50kV AC HIPOT	2534	AC - HIPOT	1/8/2023	1/8/2024

MEDIUM VOLTAGE VACUUM MOTOR STARTER TEST



CUSTOMER Orange Cogen PAGE _____
 ADDRESS 1901 S. Clear Springs Rd; Bartow FL 33830 DATE 10/2/2023
 OWNER Orange Cogen; 1901 S. Clear Springs Rd; Bartow FL 33830 JOB # OCFL2310066
 SITE Orange Cogen TEST STATUS _____ Pass _____
 SUBSTATION Main MCC ASSET ID 350 HP/013D150 Primary Circ Water Pump - 3
 EQUIPMENT 4160 Starters AMBIENT TEMPERATURE 70 °F HUMIDITY 61 %

NAMEPLATE DATA

MANUFACTURER Siemens SERIAL NO. RAL-71921-11FB-072894 TYPE AC Contactor -FM
 CATALOG NO. 93H3533034A3A STARTER SIZE 4800 FORM N/A
 SERIES 93H35 AC Contactor MAXIMUM VOLTAGE 5000 INT. RATING kA @ kV
 OPERATING VOLTAGE 4160 CONTROL VOLTAGE 125 Other _____
 MOTOR CONTROL CENTER SYSTEM VOLTAGE _____ STARTER IDENTIFICATION _____

OVERCURRENT PROTECTION DEVICES

CONTROL POWER FUSE: MFR. Gould Shawmut TYPE PT Fuse SIZE 4800 V -2E amps
 MAIN POWER FUSE: MFR. Gould Shawmut - Amp-Trap TYPE Current Limiting Fuse SIZE 2400/4800V - 225 amps
 OVERLOAD PROTECTION: _____ TYPE _____ TESTED YES NO

INSTRUMENT TRANSFORMER DATA

CONTROL POWER TRANSFORMER: MFR. Siemens Energy VA RATING 115 TYPE CPT VOLTAGE 4000
 CURRENT TRANSFORMER: MFR. _____ RATIO :5 TYPE _____ CAT. NO. _____

Description	INSPECTED	CONDITION	CLEAN/LUBE
OVERALL CLEANLINESS	<input checked="" type="checkbox"/>	Good	
INSULATING MEMBERS	<input checked="" type="checkbox"/>	Good	
MECHANICAL CONNECTIONS	<input checked="" type="checkbox"/>	Good	
STRUCTURAL MEMBERS	<input checked="" type="checkbox"/>	Good	
CUBICLE	<input checked="" type="checkbox"/>	Good	
RACKING DEVICES	<input checked="" type="checkbox"/>	Good	
SHUTTER	<input checked="" type="checkbox"/>	Good	

Description	INSPECTED	CONDITION	CLEAN/LUBE
OPERATING MECHANISM	<input checked="" type="checkbox"/>	Good	
CONTACT FINGERS	<input checked="" type="checkbox"/>	Good	
VACUUM INTERRUPTER	<input checked="" type="checkbox"/>	Good	
CONTACT EROSION INDICATOR	<input checked="" type="checkbox"/>	Good	
CONTACT SEQUENCE	<input checked="" type="checkbox"/>	Good	
GROUND CONNECTIONS	<input checked="" type="checkbox"/>	Good	
AUXILIARY DEVICES	<input checked="" type="checkbox"/>	Good	

TEMPERATURE CORRECTION FACTOR TO: 20°C 40°C
 INSULATION TEST VOLTAGE 5000 KVDC TEST VOLTAGE MULTIPLIER, K1 = _____ K2 = (K1) (TCF)
 EQUIPMENT TEMPERATURE 20 °C TEMPERATURE CORRECTION FACTOR TO 20°C, TCF 1
 MILLIWATT LOSS TEST VOLTAGE _____ KVDC HIGH POTENTIAL TEST VOLTAGE _____ KVDC 12,000 KVAC

INSULATION TESTS	POLE 1	POLE 2	POLE 3
	READING	READING	READING
POLE TO POLE - CLOSED	3.84 T	4.65 T	8.67 T
POLE TO FRAME - CLOSED	5.48 T	8.34 T	9.40 T
LINE TO FRAME - OPEN	4.82 T	3.02 T	2.19 T
LOAD TO FRAME - OPEN	3.21 T	3.49 T	3.05 T
LINE TO LOAD - OPEN	4.37 T	5.51 T	4.43 T

CONTACT MEASUREMENTS

	POLE 1	POLE 2	POLE 3
POLE RESISTANCE	RDG. 120	100	111
MICRO - OHMS			
MAIN FUSE	RDG. 1.8	1.1	1.1
CPT - FUSE	20°C 1.4	1.7	

CONTROL WIRING - MEGOHMS			
READING		20°C	

		POLE 1	POLE 2	POLE 3
HIPOT - OPEN	AC	4.0	4.0	4.0
HIPOT - CLOSED	AC	4.0	4.0	4.0

TESTED BY: Matthew Falchetti / Andrew Kirk

MEDIUM VOLTAGE VACUUM MOTOR STARTER TEST



PAGE _____

COMMENTS:

DEFICIENCIES:

EQUIPMENT USED:

#	Manufacturer	Model	Serial / ID Number	Type	Calibration Date	Calibration Due
1	FLUKE	FLUKE - 87V	38210208	MULTIMETER	1/14/2023	1/14/2024
2	MEGGER	10 kv	102311999	INSULATION	1/10/2023	1/10/2024
3	MEGGER	1006-603	102305978	DLRO10HD	1/14/2023	1/14/2024
4	HVI	50kV AC HIPOT	2534	AC - HIPOT	1/8/2023	1/8/2024

MEDIUM VOLTAGE VACUUM MOTOR STARTER TEST



CUSTOMER Orange Cogen PAGE _____
 ADDRESS 1901 S. Clear Springs Rd; Bartow FL 33830 DATE 10/2/2023
 OWNER Orange Cogen; 1901 S. Clear Springs Rd; Bartow FL 33830 JOB # OCFL2310066
 SITE Orange Cogen TEST STATUS _____ Pass
 SUBSTATION Main MCC ASSET ID 250 HP/020D130 Gas BSTR Compressor - 1
 EQUIPMENT 4160 Starters AMBIENT TEMPERATURE 70 °F HUMIDITY 61 %

NAMEPLATE DATA

MANUFACTURER Siemens SERIAL NO. RAL-71921-1RC-072894 TYPE AC Contactor -FM
 CATALOG NO. 93H3533034A3A STARTER SIZE 4800 FORM N/A
 SERIES 93H35 AC Contactor MAXIMUM VOLTAGE 5000 INT. RATING kA @ kV
 OPERATING VOLTAGE 4160 CONTROL VOLTAGE 125 Other _____
 MOTOR CONTROL CENTER SYSTEM VOLTAGE _____ STARTER IDENTIFICATION _____

OVERCURRENT PROTECTION DEVICES

CONTROL POWER FUSE: MFR. Gould Shawmut TYPE PT Fuse SIZE 4800 V -2E amps
 MAIN POWER FUSE: MFR. Gould Shawmut - Amp-Trap TYPE Current Limiting Fuse SIZE 2400/4800V - 225 amps
 OVERLOAD PROTECTION: _____ TYPE _____ TESTED YES NO

INSTRUMENT TRANSFORMER DATA

CONTROL POWER TRANSFORMER: MFR. Siemens Energy VA RATING 115 TYPE CPT VOLTAGE 4000
 CURRENT TRANSFORMER: MFR. _____ RATIO :5 TYPE _____ CAT. NO. _____

Description	INSPECTED	CONDITION	CLEAN/LUBE
OVERALL CLEANLINESS	✓	Good	
INSULATING MEMBERS	✓	Good	
MECHANICAL CONNECTIONS	✓	Good	
STRUCTURAL MEMBERS	✓	Good	
CUBICLE	✓	Good	
RACKING DEVICES	✓	Good	
SHUTTER	✓	Good	

Description	INSPECTED	CONDITION	CLEAN/LUBE
OPERATING MECHANISM	✓	Good	
CONTACT FINGERS	✓	Good	
VACUUM INTERRUPTER	✓	Good	
CONTACT EROSION INDICATOR	✓	Good	
CONTACT SEQUENCE	✓	Good	
GROUND CONNECTIONS	✓	Good	
AUXILIARY DEVICES	✓	Good	

TEMPERATURE CORRECTION FACTOR TO: 20°C 40°C
 INSULATION TEST VOLTAGE 5000 KVDC TEST VOLTAGE MULTIPLIER, K1 = _____ K2 = (K1) (TCF)
 EQUIPMENT TEMPERATURE 20 °C TEMPERATURE CORRECTION FACTOR TO 20°C, TCF 1
 MILLIWATT LOSS TEST VOLTAGE _____ KVDC HIGH POTENTIAL TEST VOLTAGE _____ KVDC 12,000 KVAC

INSULATION TESTS	POLE 1	POLE 2	POLE 3
	READING	READING	READING
POLE TO POLE - CLOSED	2.88 T	3.49 T	4.51 T
POLE TO FRAME - CLOSED	1.43 T	1.39 T	1.27 T
LINE TO FRAME - OPEN	2.31 T	1.97 T	3.00 T
LOAD TO FRAME - OPEN	1.40 T	1.27 T	2.09 T
LINE TO LOAD - OPEN	1.25 T	2.27 T	3.77 T

CONTACT MEASUREMENTS

	POLE 1	POLE 2	POLE 3
POLE RESISTANCE	RDG. 100	102	103
MICRO - OHMS			
MAIN FUSE	RDG. 0.4	0.4	0.5
CPT - FUSE	20°C 0.8	0.8	

CONTROL WIRING - MEGOHMS			
READING		20°C	

		POLE 1	POLE 2	POLE 3
HIPOT - OPEN	AC	3.8	4.0	3.8
HIPOT - CLOSED	AC	3.8	4.0	4.0

TESTED BY: Matthew Falchetti / Andrew Kirk

MEDIUM VOLTAGE VACUUM MOTOR STARTER TEST



PAGE _____

COMMENTS:

DEFICIENCIES:

EQUIPMENT USED:

#	Manufacturer	Model	Serial / ID Number	Type	Calibration Date	Calibration Due
1	FLUKE	FLUKE - 87V	38210208	MULTIMETER	1/14/2023	1/14/2024
2	MEGGER	10 kv	102311999	INSULATION	1/10/2023	1/10/2024
3	MEGGER	1006-603	102305978	DLRO10HD	1/14/2023	1/14/2024
4	HVI	50kV AC HIPOT	2534	AC - HIPOT	1/8/2023	1/8/2024

MEDIUM VOLTAGE VACUUM MOTOR STARTER TEST



CUSTOMER Orange Cogen PAGE _____
 ADDRESS 1901 S. Clear Springs Rd; Bartow FL 33830 DATE 10/2/2023
 OWNER Orange Cogen; 1901 S. Clear Springs Rd; Bartow FL 33830 JOB # OCFL2310066
 SITE Orange Cogen TEST STATUS _____ Pass
 SUBSTATION Main MCC ASSET ID 250 HP 006D625 Feedwater Pump - 2
 EQUIPMENT 4160 Starters AMBIENT TEMPERATURE 70 °F HUMIDITY 61 %

NAMEPLATE DATA

MANUFACTURER Siemens SERIAL NO. RAL-71921-1FC-072994 TYPE AC Contactor -FM
 CATALOG NO. 93H3533034A3A STARTER SIZE 4800 FORM N/A
 SERIES 93H35 AC Contactor MAXIMUM VOLTAGE 5000 INT. RATING _____ kA @ _____ kV
 OPERATING VOLTAGE 4160 CONTROL VOLTAGE 125 Other _____
 MOTOR CONTROL CENTER SYSTEM VOLTAGE _____ STARTER IDENTIFICATION _____

OVERCURRENT PROTECTION DEVICES

CONTROL POWER FUSE: MFR. Gould Shawmut TYPE PT Fuse SIZE 4800 V -2E amps
 MAIN POWER FUSE: MFR. Gould Shawmut - Amp-Trap TYPE Current Limiting Fuse SIZE 2400/4800V - 225 amps
 OVERLOAD PROTECTION: _____ TYPE _____ TESTED YES NO

INSTRUMENT TRANSFORMER DATA

CONTROL POWER TRANSFORMER: MFR. Siemens Energy VA RATING 115 TYPE CPT VOLTAGE 4000
 CURRENT TRANSFORMER: MFR. _____ RATIO _____:5 TYPE _____ CAT. NO. _____

Description	INSPECTED	CONDITION	CLEAN/LUBE
OVERALL CLEANLINESS	<input checked="" type="checkbox"/>	Good	
INSULATING MEMBERS	<input checked="" type="checkbox"/>	Good	
MECHANICAL CONNECTIONS	<input checked="" type="checkbox"/>	Good	
STRUCTURAL MEMBERS	<input checked="" type="checkbox"/>	Good	
CUBICLE	<input checked="" type="checkbox"/>	Good	
RACKING DEVICES	<input checked="" type="checkbox"/>	Good	
SHUTTER	<input checked="" type="checkbox"/>	Good	

Description	INSPECTED	CONDITION	CLEAN/LUBE
OPERATING MECHANISM	<input checked="" type="checkbox"/>	Good	
CONTACT FINGERS	<input checked="" type="checkbox"/>	Good	
VACUUM INTERRUPTER	<input checked="" type="checkbox"/>	Good	
CONTACT EROSION INDICATOR	<input checked="" type="checkbox"/>	Good	
CONTACT SEQUENCE	<input checked="" type="checkbox"/>	Good	
GROUND CONNECTIONS	<input checked="" type="checkbox"/>	Good	
AUXILIARY DEVICES	<input checked="" type="checkbox"/>	Good	

TEMPERATURE CORRECTION FACTOR TO: 20°C 40°C
 INSULATION TEST VOLTAGE 5000 KVDC TEST VOLTAGE MULTIPLIER, K1 = _____ K2 = (K1) (TCF)
 EQUIPMENT TEMPERATURE 20 °C TEMPERATURE CORRECTION FACTOR TO 20°C, TCF 1
 MILLIWATT LOSS TEST VOLTAGE _____ KVDC HIGH POTENTIAL TEST VOLTAGE _____ KVDC 12,000 KVAC

INSULATION TESTS	POLE 1	POLE 2	POLE 3
	READING	READING	READING
POLE TO POLE - CLOSED	5.23 T	4.73 T	5.87 T
POLE TO FRAME - CLOSED	2.30 T	2.54 T	2.61 T
LINE TO FRAME - OPEN	2.58 T	996 G	1.43 T
LOAD TO FRAME - OPEN	948 G	847 G	1.18 T
LINE TO LOAD - OPEN	1.74 T	2.33 T	2.72 T

CONTACT MEASUREMENTS

	POLE 1	POLE 2	POLE 3
POLE RESISTANCE	RDG. 110	161	154
MICRO - OHMS			
MAIN FUSE	RDG. 0.8	0.8	0.8
CPT - FUSE	20°C 1.1	1.1	

CONTROL WIRING - MEGOHMS			
READING		20°C	

		POLE 1	POLE 2	POLE 3
HIPOT - OPEN	AC	4.2	4.2	4.0
HIPOT - CLOSED	AC	4.0	4.0	4.2

TESTED BY: Matthew Falchetti / Andrew Kirk

MEDIUM VOLTAGE VACUUM MOTOR STARTER TEST



PAGE _____

COMMENTS:

DEFICIENCIES:

EQUIPMENT USED

#	Manufacturer	Model	Serial / ID Number	Type	Calibration Date	Calibration Due
1	FLUKE	FLUKE - 87V	38210208	MULTIMETER	1/14/2023	1/14/2024
2	MEGGER	10 kv	102311999	INSULATION	1/10/2023	1/10/2024
3	MEGGER	1006-603	102305978	DLRO10HD	1/14/2023	1/14/2024
4	HVI	50kV AC HIPOT	2534	AC - HIPOT	1/8/2023	1/8/2024

VACUUM CIRCUIT BREAKER TEST



CUSTOMER Orange Cogen PAGE _____
 ADDRESS 1901 S. Clear Springs Rd; Bartow FL 33830 DATE 9/30/2023
 OWNER Orange Cogen; 1901 S. Clear Springs Rd; Bartow FL 33830 JOB # OCFL2310066
 SITE Orange Cogen TEST STATUS _____ Pass
 SUBSTATION Main MCC ASSET ID Main Breaker - 52-2A
 EQUIPMENT 5kV Breakers AMBIENT TEMPERATURE 75 °F HUMIDITY 61 %

MANUFACTURER Siemens SERIAL NUMBER R-99515A-4
 TYPE 5-GMI-250-1200-58 MODEL NO. AC High Voltage Circuit Breaker DATE MANUFACTURED 1994
 MAXIMUM VOLTAGE 5000 kV AMPACITY 1200 OPERATING VOLTAGE 4.76 kV
 INTERRUPTING CAPACITY 29 kA @ 1.24 kV TO _____ kV = _____ mVA

Description	INSPECTED	CONDITION	CLEAN/LUBE
OVERALL CLEANLINESS	✓	Good	
INSULATING MEMBERS	✓	Good	
MECHANICAL CONNECTIONS	✓	Good	
STRUCTURAL MEMBERS	✓	Good	
CUBICLE	✓	Good	
RACKING DEVICES	✓	Good	
SHUTTER	✓	Good	

Description	INSPECTED	CONDITION	CLEAN/LUBE
CONTACT FINGERS	✓	Good	
VACUUM BOTTLE	✓	Good	
CONTACT EROSION INDICATOR	✓	Good	
OPERATING MECHANISM	✓	Good	
CONTACT SEQUENCE	✓	Good	
GROUND CONNECTION	✓	Good	
AUXILIARY DEVICES	✓	Good	

INSULATION TEST VOLTAGE 5,000 kVDC EQUIPMENT TEMPERATURE 20 °C
 MILLIWATT LOSS TEST VOLTAGE _____ kVAC HIGH POTENTIAL TEST VOLTAGE 14000 kVAC

INSULATION RESISTANCE	POLE 1	POLE 2	POLE 3
	READING	READING	READING
POLE TO POLE (CLOSED)	1.37 T	1.05 T	1.31 T
POLE TO FRAME (CLOSED)	650 G	653 G	427 G
LINE TO FRAME (OPEN)	2.13 T	1.87 T	1.33 T
LOAD TO FRAME (OPEN)	2.27 T	2.07 T	1.61 T
LINE TO LOAD (OPEN)	1.37 T	1.81 T	1.27 T

	POLE 1	POLE 2	POLE 3
HIPOT - CLOSED kVAC	9.2	9.4	9.2
HIPOT - OPEN kVAC	9.4	9.2	9.4

CONTACT MEASUREMENTS	POLE 1	POLE 2	POLE 3
FUSES - OHMS			
CONTACT RESISTANCE MICRO-OHMS	RDG. 22	15	24

COUNTER READING: BEG. 00800
 END 00801

COMMENTS: _____
 DEFICIENCIES: _____

EQUIPMENT USED	#	Manufacturer	Model	Serial / ID Number	Type	Calibration Date	Calibration Due
	1	FLUKE	FLUKE - 87V	38210208	MULTIMETER	12/14/2022	12/14/2023
	2	MEGGER	10 kV	102345653	INSULATION F	12/20/2022	1/1/1970
	3	MEGGER	1006-603	102354950	DLRO10HD	12/20/2022	1/1/1970
	4	HVI	50kV AC HIPOT	2534	AC - HIPOT	12/8/2022	1/1/1970

TESTED BY: Chris Weedman / Andrew Kirk

VACUUM CIRCUIT BREAKER TEST



CUSTOMER Orange Cogen PAGE _____
 ADDRESS 1901 S. Clear Springs Rd; Bartow FL 33830 DATE 9/30/2023
 OWNER Orange Cogen; 1901 S. Clear Springs Rd; Bartow FL 33830 JOB # OCFL2310066
 SITE Orange Cogen TEST STATUS _____ Pass
 SUBSTATION Main MCC ASSET ID Station Service Trans. 216E220
 EQUIPMENT 5kV Breakers AMBIENT TEMPERATURE 75 °F HUMIDITY 61 %

MANUFACTURER Siemens SERIAL NUMBER R-99515A-6
 TYPE 5-GMI-250-1200-58 MODEL NO. AC High Voltage Circuit Breaker DATE MANUFACTURED 1994
 MAXIMUM VOLTAGE 5000 kV AMPACITY 1200 OPERATING VOLTAGE 4.76 kV
 INTERRUPTING CAPACITY 29 kA @ 1.24 kV TO _____ kV = _____ mVA

Description	INSPECTED	CONDITION	CLEAN/LUBE
OVERALL CLEANLINESS	✓	Good	
INSULATING MEMBERS	✓	Good	
MECHANICAL CONNECTIONS	✓	Good	
STRUCTURAL MEMBERS	✓	Good	
CUBICLE	✓	Good	
RACKING DEVICES	✓	Good	
SHUTTER	✓	Good	

Description	INSPECTED	CONDITION	CLEAN/LUBE
CONTACT FINGERS	✓	Good	
VACUUM BOTTLE	✓	Good	
CONTACT EROSION INDICATOR	✓	Good	
OPERATING MECHANISM	✓	Good	
CONTACT SEQUENCE	✓	Good	
GROUND CONNECTION	✓	Good	
AUXILIARY DEVICES	✓	Good	

INSULATION TEST VOLTAGE 5,000 kVDC EQUIPMENT TEMPERATURE 20 °C
 MILLIWATT LOSS TEST VOLTAGE _____ kVAC HIGH POTENTIAL TEST VOLTAGE 14000 kVAC

INSULATION RESISTANCE	POLE 1	POLE 2	POLE 3
	READING	READING	READING
POLE TO POLE (CLOSED)	3.60 T	5.11 T	4.27 T
POLE TO FRAME (CLOSED)	860 G	1.23 T	5.3 T
LINE TO FRAME (OPEN)	608 G	1.44 T	1.23 T
LOAD TO FRAME (OPEN)	653 G	1.23 T	1.41 T
LINE TO LOAD (OPEN)	3.41 T	1.99 T	3.87 T

	POLE 1	POLE 2	POLE 3
HIPOT - CLOSED kVAC	9.2	9.4	9.4
HIPOT - OPEN kVAC	9.2	9.4	9.2

CONTACT MEASUREMENTS	POLE 1	POLE 2	POLE 3
FUSES - OHMS			
CONTACT RESISTANCE MICRO-OHMS	RDG. 22	22	21

COUNTER READING: BEG. 00553
 END 00554

COMMENTS: _____
 DEFICIENCIES: _____

EQUIPMENT USED	#	Manufacturer	Model	Serial / ID Number	Type	Calibration Date	Calibration Due
	1	FLUKE	FLUKE - 87V	38210208	MULTIMETER	1/14/2023	1/14/2024
	2	MEGGER	10 kV	102345653	INSULATION	1/20/2023	1/20/2024
	3	MEGGER	1006-603	102354950	DLRO10HD	1/20/2023	1/20/2024
	4	HVI	50kV AC HIPOT	2534	AC - HIPOT	1/8/2023	1/8/2024

TESTED BY: Matthew Falchetti / Andrew Kirk

VACUUM CIRCUIT BREAKER TEST



CUSTOMER Orange Cogen PAGE _____
 ADDRESS 1901 S. Clear Springs Rd; Bartow FL 33830 DATE 10/6/2023
 OWNER Orange Cogen; 1901 S. Clear Springs Rd; Bartow FL 33830 JOB # OCFL2310066
 SITE Orange Cogen TEST STATUS _____ Pass
 SUBSTATION Main MCC ASSET ID Station Service Trans. 116E220
 EQUIPMENT 5kV Breakers AMBIENT TEMPERATURE 77 °F HUMIDITY 65 %

MANUFACTURER Siemens SERIAL NUMBER R-99515A-1
 TYPE 5-GMI-250-1200-58 MODEL NO. AC High Voltage Circuit Breaker DATE MANUFACTURED 1994
 MAXIMUM VOLTAGE 5000 kV AMPACITY 1200 OPERATING VOLTAGE 4.76 kV
 INTERRUPTING CAPACITY 29 kA @ 1.24 kV TO _____ kV = _____ mVA

Description	INSPECTED	CONDITION	CLEAN/LUBE
OVERALL CLEANLINESS	<input checked="" type="checkbox"/>	Good	
INSULATING MEMBERS	<input checked="" type="checkbox"/>	Good	
MECHANICAL CONNECTIONS	<input checked="" type="checkbox"/>	Good	
STRUCTURAL MEMBERS	<input checked="" type="checkbox"/>	Good	
CUBICLE	<input checked="" type="checkbox"/>	Good	
RACKING DEVICES	<input checked="" type="checkbox"/>	Good	
SHUTTER	<input checked="" type="checkbox"/>	Good	

Description	INSPECTED	CONDITION	CLEAN/LUBE
CONTACT FINGERS	<input checked="" type="checkbox"/>	Good	
VACUUM BOTTLE	<input checked="" type="checkbox"/>	Good	
CONTACT EROSION INDICATOR	<input checked="" type="checkbox"/>	Good	
OPERATING MECHANISM	<input checked="" type="checkbox"/>	Good	
CONTACT SEQUENCE	<input checked="" type="checkbox"/>	Good	
GROUND CONNECTION	<input checked="" type="checkbox"/>	Good	
AUXILIARY DEVICES	<input checked="" type="checkbox"/>	Good	

INSULATION TEST VOLTAGE 5,000 kVDC EQUIPMENT TEMPERATURE 20 °C
 MILLIWATT LOSS TEST VOLTAGE _____ kVAC HIGH POTENTIAL TEST VOLTAGE 14000 kVAC

INSULATION RESISTANCE	POLE 1	POLE 2	POLE 3
	READING	READING	READING
POLE TO POLE (CLOSED)	1.04 T	1.13 T	1.02 T
POLE TO FRAME (CLOSED)	985 G	992 G	987 G
LINE TO FRAME (OPEN)	258 G	648 G	932 G
LOAD TO FRAME (OPEN)	411 G	518 G	451 G
LINE TO LOAD (OPEN)	589 G	1.09 T	1.09 T

	POLE 1	POLE 2	POLE 3
HIPOT - CLOSED kVAC	9.0	9.2	9.2
HIPOT - OPEN kVAC	9.2	9.4	9.2

CONTACT MEASUREMENTS	POLE 1	POLE 2	POLE 3
FUSES - OHMS			
CONTACT RESISTANCE MICRO-OHMS	RDG. 22	22	20

COUNTER READING: BEG. 00489
 END 00490

COMMENTS: _____
 DEFICIENCIES: _____

EQUIPMENT USED	#	Manufacturer	Model	Serial / ID Number	Type	Calibration Date	Calibration Due
	1	FLUKE	FLUKE - 87V	38210208	MULTIMETER	1/14/2023	1/14/2024
	2	MEGGER	10 kV	102345653	INSULATION	1/20/2023	1/20/2024
	3	MEGGER	1006-603	102354950	DLRO10HD	1/20/2023	1/20/2024
	4	HVI	50kV AC HIPOT	2534	AC - HIPOT	1/8/2023	1/8/2024

TESTED BY: Matthew Falchetti / Andrew Kirk

VACUUM CIRCUIT BREAKER TEST



CUSTOMER Orange Cogen PAGE _____
 ADDRESS 1901 S. Clear Springs Rd; Bartow FL 33830 DATE 10/6/2023
 OWNER Orange Cogen; 1901 S. Clear Springs Rd; Bartow FL 33830 JOB # OCFL2310066
 SITE Orange Cogen TEST STATUS _____ Pass
 SUBSTATION Main MCC ASSET ID Main Breaker - 52-1A
 EQUIPMENT 5kV Breakers AMBIENT TEMPERATURE 77 °F HUMIDITY 65 %

MANUFACTURER Siemens SERIAL NUMBER R-99515A-5
 TYPE 5-GMI-250-1200-58 MODEL NO. AC High Voltage Circuit Breaker DATE MANUFACTURED 1994
 MAXIMUM VOLTAGE 5000 kV AMPACITY 1200 OPERATING VOLTAGE 4.76 kV
 INTERRUPTING CAPACITY 29 kA @ 1.24 kV TO _____ kV = _____ mVA

Description	INSPECTED	CONDITION	CLEAN/LUBE
OVERALL CLEANLINESS	✓	Good	
INSULATING MEMBERS	✓	Good	
MECHANICAL CONNECTIONS	✓	Good	
STRUCTURAL MEMBERS	✓	Good	
CUBICLE	✓	Good	
RACKING DEVICES	✓	Good	
SHUTTER	✓	Good	

Description	INSPECTED	CONDITION	CLEAN/LUBE
CONTACT FINGERS	✓	Good	
VACUUM BOTTLE	✓	Good	
CONTACT EROSION INDICATOR	✓	Good	
OPERATING MECHANISM	✓	Good	
CONTACT SEQUENCE	✓	Good	
GROUND CONNECTION	✓	Good	
AUXILIARY DEVICES	✓	Good	

INSULATION TEST VOLTAGE 5,000 kVDC EQUIPMENT TEMPERATURE 20 °C
 MILLIWATT LOSS TEST VOLTAGE _____ kVAC HIGH POTENTIAL TEST VOLTAGE 14000 kVAC

INSULATION RESISTANCE	POLE 1	POLE 2	POLE 3
	READING	READING	READING
POLE TO POLE (CLOSED)	1.08 T	1.09 T	1.05 T
POLE TO FRAME (CLOSED)	1.07 T	1.06 T	1.03 T
LINE TO FRAME (OPEN)	258 G	648 G	932 G
LOAD TO FRAME (OPEN)	411 G	518 G	451 G
LINE TO LOAD (OPEN)	1.14 T	1.13 T	1.2 T

	POLE 1	POLE 2	POLE 3
HIPOT - CLOSED kVAC	9.0	9.0	9.0
HIPOT - OPEN kVAC	9.2	9.2	9.2

CONTACT MEASUREMENTS	POLE 1	POLE 2	POLE 3
FUSES - OHMS			
CONTACT RESISTANCE MICRO-OHMS	RDG. 28	21	22

COUNTER READING: BEG. 00604
 END 00605

COMMENTS: _____
 DEFICIENCIES: _____

EQUIPMENT USED	#	Manufacturer	Model	Serial / ID Number	Type	Calibration Date	Calibration Due
	1	FLUKE	FLUKE - 87V	38210208	MULTIMETER	12/14/2022	12/14/2023
	2	MEGGER	10 kV	102345653	INSULATION	12/20/2022	1/1/1970
	3	MEGGER	1006-603	102354950	DLRO10HD	12/20/2022	1/1/1970
	4	HVI	50kV AC HIPOT	2534	AC - HIPOT	12/8/2022	1/1/1970

TESTED BY: Chris Weedman / Andrew Kirk

VACUUM CIRCUIT BREAKER TEST



CUSTOMER Orange Cogen PAGE _____
 ADDRESS 1901 S. Clear Springs Rd; Bartow FL 33830 DATE 9/30/2023
 OWNER Orange Cogen; 1901 S. Clear Springs Rd; Bartow FL 33830 JOB # OCFL2310066
 SITE Orange Cogen TEST STATUS _____ Pass
 SUBSTATION Main MCC ASSET ID Tie Breaker T1-52
 EQUIPMENT 5kV Breakers AMBIENT TEMPERATURE 75 °F HUMIDITY 61 %

MANUFACTURER Siemens SERIAL NUMBER R-99515A-3
 TYPE 5-GMI-250-1200-58 MODEL NO. AC High Voltage Circuit Breaker DATE MANUFACTURED 1994
 MAXIMUM VOLTAGE 5000 kV AMPACITY 1200 OPERATING VOLTAGE 4.76 kV
 INTERRUPTING CAPACITY 29 kA @ 1.24 kV TO _____ kV = _____ mVA

Description	INSPECTED	CONDITION	CLEAN/LUBE
OVERALL CLEANLINESS	✓	Good	
INSULATING MEMBERS	✓	Good	
MECHANICAL CONNECTIONS	✓	Good	
STRUCTURAL MEMBERS	✓	Good	
CUBICLE	✓	Good	
RACKING DEVICES	✓	Good	
SHUTTER	✓	Good	

Description	INSPECTED	CONDITION	CLEAN/LUBE
CONTACT FINGERS	✓	Good	
VACUUM BOTTLE	✓	Good	
CONTACT EROSION INDICATOR	✓	Good	
OPERATING MECHANISM	✓	Good	
CONTACT SEQUENCE	✓	Good	
GROUND CONNECTION	✓	Good	
AUXILIARY DEVICES	✓	Good	

INSULATION TEST VOLTAGE 5,000 kVDC EQUIPMENT TEMPERATURE 20 °C
 MILLIWATT LOSS TEST VOLTAGE _____ kVAC HIGH POTENTIAL TEST VOLTAGE 14000 kVAC

INSULATION RESISTANCE	POLE 1	POLE 2	POLE 3
	READING	READING	READING
POLE TO POLE (CLOSED)	3.17 T	6.82 T	3.95 T
POLE TO FRAME (CLOSED)	1.08 T	1.45 T	1.76 G
LINE TO FRAME (OPEN)	2.16 T	2.39 T	711 G
LOAD TO FRAME (OPEN)	1.96 T	2.12 T	1.97 T
LINE TO LOAD (OPEN)	1.33 T	1.73 T	1.68 T

	POLE 1	POLE 2	POLE 3
HIPOT - CLOSED kVAC	9.4	9.4	9.2
HIPOT - OPEN kVAC	9.3	9.2	9.2

CONTACT MEASUREMENTS	POLE 1	POLE 2	POLE 3
FUSES - OHMS			
CONTACT RESISTANCE MICRO-OHMS	RDG. 21	18	23

COUNTER READING: BEG. 00654
 END 00655

COMMENTS: _____
 DEFICIENCIES: _____

EQUIPMENT USED	#	Manufacturer	Model	Serial / ID Number	Type	Calibration Date	Calibration Due
	1	FLUKE	FLUKE - 87V	38210208	MULTIMETER	12/14/2022	12/14/2023
	2	MEGGER	10 kV	102345653	INSULATION F	12/20/2022	1/1/1970
	3	MEGGER	1006-603	102354950	DLRO10HD	12/20/2022	1/1/1970
	4	HVI	50kV AC HIPOT	2534	AC - HIPOT	12/8/2022	1/1/1970

TESTED BY: Chris Weedman / Andrew Kirk

VACUUM CIRCUIT BREAKER TEST



CUSTOMER Orange Cogen PAGE _____
 ADDRESS 1901 S. Clear Springs Rd; Bartow FL 33830 DATE 10/6/2023
 OWNER Orange Cogen; 1901 S. Clear Springs Rd; Bartow FL 33830 JOB # OCFL2310066
 SITE Orange Cogen TEST STATUS _____ Pass _____
 SUBSTATION Switch-Yard ASSET ID 52GT1 Breaker
 EQUIPMENT 15kV Breakers AMBIENT TEMPERATURE 80 °F HUMIDITY 94 %

MANUFACTURER Siemens SERIAL NUMBER 28995-00-001
 TYPE 15-GMI-1000-3000-77 MODEL NO. AC High Voltage Circuit Breaker DATE MANUFACTURED 2006
 MAXIMUM VOLTAGE 15000 kV AMPACITY 3000 OPERATING VOLTAGE 13800 kV
 INTERRUPTING CAPACITY 48 kA @ _____ kV TO _____ kV = _____ mVA

Description	INSPECTED	CONDITION	CLEAN/LUBE
OVERALL CLEANLINESS	✓	Good	
INSULATING MEMBERS	✓	Good	
MECHANICAL CONNECTIONS	✓	Good	
STRUCTURAL MEMBERS	✓	Good	
CUBICLE	✓	Good	
RACKING DEVICES	✓	Good	
SHUTTER	✓	Good	

Description	INSPECTED	CONDITION	CLEAN/LUBE
CONTACT FINGERS	✓	Good	
VACUUM BOTTLE	✓	Good	
CONTACT EROSION INDICATOR	✓	Good	
OPERATING MECHANISM	✓	Good	
CONTACT SEQUENCE	✓	Good	
GROUND CONNECTION	✓	Good	
AUXILIARY DEVICES	✓	Good	

INSULATION TEST VOLTAGE 10,000 kVDC EQUIPMENT TEMPERATURE 20 °C
 MILLIWATT LOSS TEST VOLTAGE N/A kVAC HIGH POTENTIAL TEST VOLTAGE 27000 kVAC

INSULATION RESISTANCE	POLE 1	POLE 2	POLE 3
	READING	READING	READING
POLE TO POLE (CLOSED)	9.96 G	18.1 G	13.7 G
POLE TO FRAME (CLOSED)	10.2 G	6.17 G	4.01 G
LINE TO FRAME (OPEN)	8.95 G	27.0 G	20.6 G
LOAD TO FRAME (OPEN)	3.48 G	6.64 G	10.9 G
LINE TO LOAD (OPEN)	3.97 G	23.1 G	13.02 G

	POLE 1	POLE 2	POLE 3
HIPOT - CLOSED kVAC	9.4	9.2	9.4
HIPOT - OPEN kVAC	9.6	9.4	9.6

CONTACT MEASUREMENTS	POLE 1	POLE 2	POLE 3
FUSES - OHMS			
CONTACT RESISTANCE MICRO-OHMS	RDG. 39	31	30

COUNTER READING: BEG. 02585
 END 02586

COMMENTS: _____
 DEFICIENCIES: Wheels on breaker all broke - Replaced with ones from Spare Breaker

EQUIPMENT USED	#	Manufacturer	Model	Serial / ID Number	Type	Calibration Date	Calibration Due
	1	MEGGER	10 kV	102345653	INSULATION	12/20/2022	1/1/1970
	2	MEGGER	1006-603	102305978	DLRO10HD	12/14/2022	12/14/2023
	3	HVI	50kV AC HIPOT	2534	AC - HIPOT	12/8/2022	1/1/1970

TESTED BY: Matthew Falchetti / Andrew Kirk

VACUUM CIRCUIT BREAKER TEST



CUSTOMER Orange Cogen PAGE _____
 ADDRESS 1901 S. Clear Springs Rd; Bartow FL 33830 DATE 9/28/2023
 OWNER Orange Cogen; 1901 S. Clear Springs Rd; Bartow FL 33830 JOB # OCFL2310066
 SITE Orange Cogen TEST STATUS _____ Pass
 SUBSTATION Switch-Yard ASSET ID 52STG Breaker
 EQUIPMENT 15kV Breakers AMBIENT TEMPERATURE 75 °F HUMIDITY 100 %

MANUFACTURER Siemens SERIAL NUMBER R-99512B-1
 TYPE 15-GMI-1000-2000-77 MODEL NO. AC High Voltage Circuit Breaker DATE MANUFACTURED 1994
 MAXIMUM VOLTAGE 15000 kV AMPACITY 2000 OPERATING VOLTAGE 13800 kV
 INTERRUPTING CAPACITY 37 kA @ _____ kV TO _____ kV = _____ mVA

Description	INSPECTED	CONDITION	CLEAN/LUBE
OVERALL CLEANLINESS	✓	Good	
INSULATING MEMBERS	✓	Good	
MECHANICAL CONNECTIONS	✓	Good	
STRUCTURAL MEMBERS	✓	Good	
CUBICLE	✓	Good	
RACKING DEVICES	✓	Good	
SHUTTER	✓	Good	

Description	INSPECTED	CONDITION	CLEAN/LUBE
CONTACT FINGERS	✓	Good	
VACUUM BOTTLE	✓	Good	
CONTACT EROSION INDICATOR	✓	Good	
OPERATING MECHANISM	✓	Good	
CONTACT SEQUENCE	✓	Good	
GROUND CONNECTION	✓	Good	
AUXILIARY DEVICES	✓	Good	

INSULATION TEST VOLTAGE 10,000 kVDC EQUIPMENT TEMPERATURE 20 °C
 MILLIWATT LOSS TEST VOLTAGE N/A kVAC HIGH POTENTIAL TEST VOLTAGE 27000 kVAC

INSULATION RESISTANCE	POLE 1	POLE 2	POLE 3
	READING	READING	READING
POLE TO POLE (CLOSED)	1.65 G	2.64 G	3.04 G
POLE TO FRAME (CLOSED)	2.20 G	3.86 G	2.59 G
LINE TO FRAME (OPEN)	3.41 G	12.54 G	5.37 G
LOAD TO FRAME (OPEN)	13.95 G	8.4 G	3.26 G
LINE TO LOAD (OPEN)	4.82 G	11.44 G	8.65 G

	POLE 1	POLE 2	POLE 3
HIPOT - CLOSED kVAC	9.8	9.6	9.6
HIPOT - OPEN kVAC	9.4	9.6	9.4

CONTACT MEASUREMENTS	POLE 1	POLE 2	POLE 3	
FUSES - OHMS				
CONTACT RESISTANCE MICRO-OHMS	RDG.	15	14	16

COUNTER READING: BEG. 01058
 END 01059

COMMENTS:
 DEFICIENCIES: Open / Close interlock bolt was missing and held the lever down - Fixed

EQUIPMENT USED	#	Manufacturer	Model	Serial / ID Number	Type	Calibration Date	Calibration Due
	1	MEGGER	10 kV	102345653	INSULATION	12/20/2022	1/1/1970
	2	MEGGER	1006-603	102305978	DLRO10HD	12/14/2022	12/14/2023
	3	HVI	50kV AC HIPOT	2534	AC - HIPOT	12/8/2022	1/1/1970

TESTED BY: Matthew Falchetti / Andrew Kirk

VACUUM CIRCUIT BREAKER TEST



CUSTOMER Orange Cogen PAGE _____
 ADDRESS 1901 S. Clear Springs Rd; Bartow FL 33830 DATE 9/28/2023
 OWNER Orange Cogen; 1901 S. Clear Springs Rd; Bartow FL 33830 JOB # OCFL2310066
 SITE Orange Cogen TEST STATUS _____ Pass
 SUBSTATION Switch-Yard ASSET ID 52GT2 Breaker
 EQUIPMENT 15kV Breakers AMBIENT TEMPERATURE 75 °F HUMIDITY 100 %

MANUFACTURER Siemens SERIAL NUMBER R-3006127035-100-001
 TYPE 15-GMI-1000-3000-77 MODEL NO. AC High Voltage Circuit Breaker DATE MANUFACTURED 2016
 MAXIMUM VOLTAGE 15000 kV AMPACITY 3000 OPERATING VOLTAGE 13800 kV
 INTERRUPTING CAPACITY 48 kA @ _____ kV TO _____ kV = _____ mVA

Description	INSPECTED	CONDITION	CLEAN/LUBE
OVERALL CLEANLINESS	<input checked="" type="checkbox"/>	Good	
INSULATING MEMBERS	<input checked="" type="checkbox"/>	Good	
MECHANICAL CONNECTIONS	<input checked="" type="checkbox"/>	Good	
STRUCTURAL MEMBERS	<input checked="" type="checkbox"/>	Good	
CUBICLE	<input checked="" type="checkbox"/>	Good	
RACKING DEVICES	<input checked="" type="checkbox"/>	Good	
SHUTTER	<input checked="" type="checkbox"/>	Good	

Description	INSPECTED	CONDITION	CLEAN/LUBE
CONTACT FINGERS	<input checked="" type="checkbox"/>	Good	
VACUUM BOTTLE	<input checked="" type="checkbox"/>	Good	
CONTACT EROSION INDICATOR	<input checked="" type="checkbox"/>	Good	
OPERATING MECHANISM	<input checked="" type="checkbox"/>	Good	
CONTACT SEQUENCE	<input checked="" type="checkbox"/>	Good	
GROUND CONNECTION	<input checked="" type="checkbox"/>	Good	
AUXILIARY DEVICES	<input checked="" type="checkbox"/>	Good	

INSULATION TEST VOLTAGE 10,000 kVDC EQUIPMENT TEMPERATURE 20 °C
 MILLIWATT LOSS TEST VOLTAGE N/A kVAC HIGH POTENTIAL TEST VOLTAGE 27000 kVAC

INSULATION RESISTANCE	POLE 1	POLE 2	POLE 3
	READING	READING	READING
POLE TO POLE (CLOSED)	107.3 G	80.5 G	49.4 G
POLE TO FRAME (CLOSED)	48.2 G	77.5 G	56.6 G
LINE TO FRAME (OPEN)	11.99 G	22.9 G	28.1 G
LOAD TO FRAME (OPEN)	31.7 G	42.4 G	7.54 G
LINE TO LOAD (OPEN)	17.74 G	10.66 G	12.77 G

	POLE 1	POLE 2	POLE 3
HIPOT - CLOSED kVAC	9.4	9.4	9.6
HIPOT - OPEN kVAC	9.6	9.4	9.2

CONTACT MEASUREMENTS	POLE 1	POLE 2	POLE 3
FUSES - OHMS			
CONTACT RESISTANCE MICRO-OHMS	RDG. 24	20	20

COUNTER READING: BEG. 01061
 END 01062

COMMENTS: _____
 DEFICIENCIES: _____

EQUIPMENT USED	#	Manufacturer	Model	Serial / ID Number	Type	Calibration Date	Calibration Due
	1	MEGGER	10 kV	102345653	INSULATION	12/20/2022	1/1/1970
	2	MEGGER	1006-603	102305978	DLRO10HD	12/14/2022	12/14/2023
	3	HVI	50kV AC HIPOT	2534	AC - HIPOT	12/8/2022	1/1/1970

TESTED BY: Matthew Falchetti / Andrew Kirk

CT TEST REPORT



CUSTOMER Orange Cogen PAGE _____
 ADDRESS 1901 S. Clear Springs Rd; Bartow FL 33830 DATE 9/28/2023
 USER Orange Cogen; 1901 S. Clear Springs Rd; Bartow FL 33830 JOB # OCFL2310066
 SITE Orange Cogen TEST STATUS _____ Pass
 SUBSTATION Switch-Yard ASSET ID 52-L2-X1
 EQUIPMENT 52-L2 SF-6 - CT's AMBIENT TEMPERATURE 82 °F HUMIDITY 70 %

CT: CT1		NAMEPLATE DATA				
MANUFACTURER	Siemens	SERIAL NO.			IN SERVICE TAP	
ASSET ID		ACCURACY CLASS	C800	Protection	SATURATION STD	ANSI 45
PHASE		BURDEN	B-8		VA	200

Tap	Ratio						Knee		Phase Dev.	Polarity
	Nameplate	Measured	% Error	Test V (V)	Test I (A)	Prim V (V)	Volt.(V)	Cur.(A)		
X1-X2	200:5	200.009:5	0.004	9.9829	0.1818	0.2496			359°58'	Correct
X1-X3	800:5	800.14:5	0.018	39.936	0.0455	0.2496			359°58'	Correct
X1-X4	1600:5	1600.07:5	0.005	79.863	0.0227	0.2496			359°58'	Correct
X1-X5	2000:5	1999.38:5	-0.031	99.793	0.0182	0.2496			359°58'	Correct
X2-X3	600:5	600.132:5	0.022	29.954	0.0606	0.2496			359°58'	Correct
X2-X4	1400:5	1400.07:5	0.005	69.880	0.0260	0.2496			359°58'	Correct
X2-X5	1800:5	1799.37:5	-0.035	89.810	0.0202	0.2496			359°58'	Correct
X3-X4	800:5	799.934:5	-0.008	39.926	0.0455	0.2496			359°58'	Correct
X3-X5	1200:5	1199.24:5	-0.063	59.856	0.0303	0.2496			359°58'	Correct
X4-X5	400:5	399.308:5	-0.173	19.930	0.0911	0.2496			359°58'	Correct

COMMENTS: _____
 DEFICIENCIES: _____

EQUIPMENT USE#	#	Manufacturer	Model	Serial / ID Number	Type	Calibration Date	Calibration Due
	1	MEGGER	MRCT	202211050016	CT/RELAY T	1/14/2023	1/14/2024

TEST EQUIPMENT USED: Megger MRCT 202211050016 TESTED BY: Matthew Falchetti

CT TEST REPORT



CUSTOMER Orange Cogen PAGE _____
 ADDRESS 1901 S. Clear Springs Rd; Bartow FL 33830 DATE 9/28/2023
 USER Orange Cogen; 1901 S. Clear Springs Rd; Bartow FL 33830 JOB # OCFL2310066
 SITE Orange Cogen TEST STATUS _____ Pass
 SUBSTATION Switch-Yard ASSET ID _____ 52-L2 -X3
 EQUIPMENT 52-L2 SF-6 - CT's AMBIENT TEMPERATURE 82 °F HUMIDITY 70 %

CT: CT1		NAMEPLATE DATA				
MANUFACTURER	Siemens	SERIAL NO.			IN SERVICE TAP	
ASSET ID	52-T2-SF-6 Breaker	ACCURACY CLASS	C800	Protection	SATURATION STD	ANSI 45
PHASE		BURDEN	B-8		VA	200

Tap	Ratio						Knee		Phase Dev.	Polarity
	Nameplate	Measured	% Error	Test V (V)	Test I (A)	Prim V (V)	Volt.(V)	Cur.(A)		
X1-X2	200:5	200.002:5	0.001	9.9846	0.1342	0.2496			359°58'	Correct
X1-X3	800:5	800.107:5	0.013	39.943	0.0335	0.2496			359°58'	Correct
X1-X4	1600:5	1600.02:5	0.001	79.877	0.0168	0.2496			359°58'	Correct
X1-X5	2000:5	1999.29:5	-0.035	99.809	0.0134	0.2496			359°58'	Correct
X2-X3	600:5	600.105:5	0.018	29.958	0.0447	0.2496			359°58'	Correct
X2-X4	1400:5	1400.02:5	0.001	69.892	0.0192	0.2496			359°58'	Correct
X2-X5	1800:5	1799.29:5	-0.039	89.825	0.0149	0.2496			359°58'	Correct
X3-X4	800:5	799.916:5	-0.011	39.933	0.0335	0.2496			359°58'	Correct
X4-X5	400:5	399.27:5	-0.183	19.932	0.0672	0.2496			359°58'	Correct

COMMENTS: _____
 DEFICIENCIES: _____

EQUIPMENT USED	#	Manufacturer	Model	Serial / ID Number	Type	Calibration Date	Calibration Due
	1	MEGGER	MRCT	202211050016	CT/RELAY T	1/14/2023	1/14/2024

TEST EQUIPMENT USED: Megger MRCT 202211050016 TESTED BY: Matthew Falchetti

CT TEST REPORT



CUSTOMER Orange Cogen PAGE _____
 ADDRESS 1901 S. Clear Springs Rd; Bartow FL 33830 DATE 9/28/2023
 USER Orange Cogen; 1901 S. Clear Springs Rd; Bartow FL 33830 JOB # OCFL2310066
 SITE Orange Cogen TEST STATUS _____ Pass
 SUBSTATION Switch-Yard ASSET ID _____ 52-L2-X5
 EQUIPMENT 52-L2 SF-6 - CT's AMBIENT TEMPERATURE 82 °F HUMIDITY 70 %

CT: CT1		NAMEPLATE DATA			
MANUFACTURER	Siemens	SERIAL NO.		IN SERVICE TAP	
ASSET ID		ACCURACY CLASS	C800 Protection	SATURATION STD	ANSI 45
PHASE		BURDEN	B-8	VA	200

Tap	Ratio						Knee		Phase Dev.	Polarity
	Nameplate	Measured	% Error	Test V (V)	Test I (A)	Prim V (V)	Volt.(V)	Cur.(A)		
X1-X2	200:5	200.009:5	0.004	9.9829	0.1818	0.2496			359°58'	Correct
X1-X3	800:5	800.14:5	0.018	39.936	0.0455	0.2496			359°58'	Correct
X1-X4	1600:5	1600.07:5	0.005	79.863	0.0227	0.2496			359°58'	Correct
X1-X5	2000:5	1999.38:5	-0.031	99.793	0.0182	0.2496			359°58'	Correct
X2-X3	600:5	600.132:5	0.022	29.954	0.0606	0.2496			359°58'	Correct
X2-X4	1400:5	1400.07:5	0.005	69.880	0.0260	0.2496			359°58'	Correct
X2-X5	1800:5	1799.37:5	-0.035	89.810	0.0202	0.2496			359°58'	Correct
X3-X4	800:5	799.934:5	-0.008	39.926	0.0455	0.2496			359°58'	Correct
X3-X5	1200:5	1199.24:5	-0.063	59.856	0.0303	0.2496			359°58'	Correct
X4-X5	400:5	399.308:5	-0.173	19.930	0.0911	0.2496			359°58'	Correct

COMMENTS: _____
 DEFICIENCIES: _____

EQUIPMENT USE#	#	Manufacturer	Model	Serial / ID Number	Type	Calibration Date	Calibration Due
	1	MEGGER	MRCT	202211050016	CT/RELAY T	1/14/2023	1/14/2024

TEST EQUIPMENT USED: Megger MRCT 202211050016 TESTED BY: Matthew Falchetti

CT TEST REPORT



CUSTOMER Orange Cogen PAGE _____
 ADDRESS 1901 S. Clear Springs Rd; Bartow FL 33830 DATE 10/5/2023
 USER Orange Cogen; 1901 S. Clear Springs Rd; Bartow FL 33830 JOB # OCFL2310066
 SITE Orange Cogen TEST STATUS _____ Pass
 SUBSTATION T1 Side ASSET ID _____ 52-L1-X1
 EQUIPMENT 52-L1 SF-6 - CT's AMBIENT TEMPERATURE 80 °F HUMIDITY 65 %

CT: CT1		NAMEPLATE DATA			
MANUFACTURER	Siemens	SERIAL NO.		IN SERVICE TAP	
ASSET ID		ACCURACY CLASS	C800 Protection	SATURATION STD	ANSI 45
PHASE		BURDEN	B-8	VA	200

Tap	Ratio						Knee		Phase Dev.	Polarity
	Nameplate	Measured	% Error	Test V (V)	Test I (A)	Prim V (V)	Volt.(V)	Cur.(A)		
X1-X2	200:5	200.031:5	0.015	9.9848	0.1754	0.2496			359°58'	Correct
X1-X3	800:5	800.136:5	0.017	39.939	0.0438	0.2496			359°58'	Correct
X1-X4	1600:5	1600.2:5	0.013	79.876	0.0219	0.2496			359°58'	Correct
X1-X5	2000:5	1999.65:5	-0.017	99.815	0.0175	0.2496			359°58'	Correct
X2-X3	600:5	600.105:5	0.017	29.955	0.0585	0.2496			359°58'	Correct
X2-X4	1400:5	1400.17:5	0.012	69.891	0.0251	0.2496			359°58'	Correct
X2-X5	1800:5	1799.62:5	-0.021	89.830	0.0195	0.2496			359°58'	Correct
X3-X4	800:5	800.065:5	0.008	39.936	0.0438	0.2496			359°58'	Correct
X3-X5	1200:5	1199.51:5	-0.041	59.875	0.0292	0.2496			359°58'	Correct
X4-X5	400:5	399.449:5	-0.138	19.939	0.0878	0.2496			359°58'	Correct

COMMENTS: _____
 DEFICIENCIES: _____

EQUIPMENT USE	#	Manufacturer	Model	Serial / ID Number	Type	Calibration Date	Calibration Due
	1	MEGGER	MRCT	202211050016	CT/RELAY T	1/14/2023	1/14/2024

TEST EQUIPMENT USED: Megger MRCT 202211050016 TESTED BY: Matthew Falchetti

CT TEST REPORT



CUSTOMER Orange Cogen PAGE _____
 ADDRESS 1901 S. Clear Springs Rd; Bartow FL 33830 DATE 10/5/2023
 USER Orange Cogen; 1901 S. Clear Springs Rd; Bartow FL 33830 JOB # OCFL2310066
 SITE Orange Cogen TEST STATUS _____ Pass
 SUBSTATION T1 Side ASSET ID _____ 52-L1-X5
 EQUIPMENT 52-L1 SF-6 - CT's AMBIENT TEMPERATURE 80 °F HUMIDITY 65 %

CT: CT1		NAMEPLATE DATA					
MANUFACTURER	Siemens	SERIAL NO.			IN SERVICE TAP		
ASSET ID		ACCURACY CLASS	C800	Protection	SATURATION STD	ANSI 45	
PHASE		BURDEN	B-8		VA	200	
Test Frequency	16.67Hz					Buried CT in Delta Connection	<input type="checkbox"/>

Tap	Ratio						Knee		Phase Dev.	Polarity
	Nameplate	Measured	% Error	Test V (V)	Test I (A)	Prim V (V)	Volt.(V)	Cur.(A)		
X1-X2	200:5	200.026:5	0.013	9.9959	0.2092	0.2499			359°59'	Correct
X1-X3	800:5	800.123:5	0.015	39.984	0.0523	0.2499			359°59'	Correct
X1-X4	1600:5	1600.19:5	0.012	79.966	0.0261	0.2499			359°59'	Correct
X1-X5	2000:5	1999.74:5	-0.013	99.933	0.0209	0.2499			359°59'	Correct
X2-X3	600:5	600.097:5	0.016	29.988	0.0697	0.2499			359°59'	Correct
X2-X4	1400:5	1400.16:5	0.012	69.970	0.0299	0.2499			359°59'	Correct
X2-X5	1800:5	1799.71:5	-0.016	89.937	0.0232	0.2499			359°59'	Correct
X3-X4	800:5	800.065:5	0.008	39.981	0.0523	0.2499			359°59'	Correct
X3-X5	1200:5	1199.61:5	-0.032	59.948	0.0349	0.2499			359°59'	Correct
X4-X5	400:5	399.55:5	-0.113	19.966	0.1047	0.2499			359°59'	Correct

COMMENTS: _____
 DEFICIENCIES: _____

EQUIPMENT USED	#	Manufacturer	Model	Serial / ID Number	Type	Calibration Date	Calibration Due
	1	MEGGER	MRCT	202211050016	CT/RELAY T	1/14/2023	1/14/2024

TEST EQUIPMENT USED: Megger MRCT 202211050016 TESTED BY: Matthew Falchetti

CT TEST REPORT



CUSTOMER Orange Cogen PAGE _____
 ADDRESS 1901 S. Clear Springs Rd; Bartow FL 33830 DATE 10/5/2023
 USER Orange Cogen; 1901 S. Clear Springs Rd; Bartow FL 33830 JOB # OCFL2310066
 SITE Orange Cogen TEST STATUS _____ Pass
 SUBSTATION T1 Side ASSET ID _____ 52-L1-X3
 EQUIPMENT 52-L1 SF-6 - CT's AMBIENT TEMPERATURE 80 °F HUMIDITY 65 %

CT: CT1		NAMEPLATE DATA				
MANUFACTURER	Siemens	SERIAL NO.			IN SERVICE TAP	
ASSET ID		ACCURACY CLASS	C800	Protection	SATURATION STD	ANSI 45
PHASE		BURDEN	B-8		VA	200
Test Frequency	16.67Hz	Buried CT in Delta Connection				<input type="checkbox"/>

Tap	Ratio						Knee		Phase Dev.	Polarity
	Nameplate	Measured	% Error	Test V (V)	Test I (A)	Prim V (V)	Volt.(V)	Cur.(A)		
X1-X2	200:5	200.029:5	0.014	9.9988	0.2083	0.2499			359°59'	Correct
X1-X3	800:5	800.143:5	0.018	39.996	0.0521	0.2499			359°59'	Correct
X1-X4	1600:5	1600.3:5	0.019	79.993	0.0260	0.2499			359°59'	Correct
X1-X5	2000:5	1999.83:5	-0.008	99.964	0.0208	0.2499			359°59'	Correct
X2-X3	600:5	600.114:5	0.019	29.997	0.0694	0.2499			359°59'	Correct
X2-X4	1400:5	1400.28:5	0.020	69.995	0.0298	0.2499			359°59'	Correct
X2-X5	1800:5	1799.8:5	-0.011	89.966	0.0232	0.2499			359°59'	Correct
X3-X4	800:5	800.161:5	0.020	39.997	0.0521	0.2499			359°59'	Correct
X3-X5	1200:5	1199.69:5	-0.026	59.968	0.0347	0.2499			359°59'	Correct
X4-X5	400:5	399.53:5	-0.117	19.971	0.1043	0.2499			359°59'	Correct

COMMENTS: _____
 DEFICIENCIES: _____

EQUIPMENT USED	#	Manufacturer	Model	Serial / ID Number	Type	Calibration Date	Calibration Due
	1	MEGGER	MRCT	202211050016	CT/RELAY T	1/14/2023	1/14/2024

TEST EQUIPMENT USED: Megger MRCT 202211050016

TESTED BY: Matthew Falchetti

T2 - GSU Transformer



Client	Orange Cogen	OCFL2310066 - T2 - GSU	
Execution date	9/29/2023	Reason of the job	Post fault
Tested by	Matthew Falchetti	Location	Orange Cogen
Approved by		Asset	Transformer
Report ID	2	Asset type	Three-winding
Report issue date	10/13/2023 8:43:21 AM	Asset serial number	LNL9182
Work order		Manufacturer	ABB

Summary

Performed tests	Assessment
Overall PF & CAP	Pass
Bushing H PF & CAP - C1	Pass
Bushing H PF & CAP - C2	Pass
Bushing H – Energized Collar	Pass
Bushing X – Energized Collar	Pass
Bushing Y – Energized Collar	Pass
Exciting Current	Pass
Surge Arrester Watt Losses H	Pass
TTR H-X	Pass
TTR H-Y	Pass
DC Winding Resistance H	Pass
DC Winding Resistance X	Pass
DC Winding Resistance Y	Pass
Insulation Resistance	Pass

Overall Assessment	No Faults
--------------------	-----------

Tested by:

Andrew Kirk

Approved by:

Matthew Falchetti

Location & company information			
Location		Company	
Name	Orange Cogen	Company	HVA – P&C / Field Services
Region		Department	South
Division	South	Address	
Area		City	Lakeland
Plant	Orange Cogen	State/Province	Florida
Address	1901 S. Clear Springs Rd	Postal code	33811
City	Bartow	Country	United States
State/Province	Florida	Phone No.	
Postal code	33830	Fax No.	
Country	United States	E-mail	

Geo coordinates	
-----------------	--

Contact person	
Name	
Phone No. 1	
Phone No. 2	
Fax No.	
E-mail	

Comment

Transformer nameplate data			
Serial number	LNL9182	Apparatus ID	T2 - GSU
Manufacturer	ABB	Feeder	
Manufacturing year	1994	No. phases	3
Manufacturer type	SL	Vector group	YNd1d1

Comment

Voltage ratings			
Winding	Voltage L-L	Voltage L-N	Insul. level L-L
H	70.690 kV	40.813 kV	350 kV
X	13.800 kV	kV	110 kV
Y	13.800 kV	kV	110 kV

Power ratings		
Rated power	Cooling class	Temp. rise wind.
33.000 MVA	OA	

Current ratings at rated power			
Winding			
H	X	Y	Rated power
927.000 A	2062.000 A	2687.000 A	33.000 MVA

Short-circuit rating		
Max. short-circuit current	kA	s

Impedances

Ref. temp.	75 °C
------------	-------

Leakage reactance H - X

Zk[%]	Base power	Base voltage	Load losses Pk	OLTC position	DETC position
%	MVA	kV	W		

Leakage reactance H - Y

Zk[%]	Base power	Base voltage	Load losses Pk	OLTC position	DETC position
%	MVA	kV	W		

Leakage reactance X - Y

Zk[%]	Base power	Base voltage	Load losses Pk	OLTC position	DETC position
%	MVA	kV	W		

Zero sequence impedance

Base power	33.00 MVA
Base voltage	72.500 kV
Description	Z0[%]
Primary	13.07 %

Others

Category	Generation
Status	In operation
Tank type	Nitrogen blanketed
Insulation medium	Mineral oil
Fluid insulation volume	9998 gals
Fluid insulation weight	lbs
Total weight	288115 lbs

Bushings nameplate data

Pos.	Serial No.	Manufact.	Manufacturer type	Man. year	Voltage L-ground	Max. system voltage	Rated current
H1	3785220394	ABB	O Plus C	1994	44.0 kV	69.0 kV	400.0 A
H2	3785220294	ABB	O Plus C	1994	44.0 kV	69.0 kV	400.0 A
H3	3785220194	ABB	O Plus C	1994	44.0 kV	69.0 kV	400.0 A
H0	2785200194	ABB		1994	15.0 kV	15.0 kV	1200.0 A
X1	8C01085406	ABB		1998	10.0 kV	15.0 kV	3300.0 A
X2	8C01085405	ABB		1998	10.0 kV	15.0 kV	3300.0 A
X3	8C01085401	ABB		1998	10.0 kV	15.0 kV	3300.0 A
Y1	8C01085402	ABB		1998	10.0 kV	15.0 kV	3300.0 A
Y2	8C01085404	ABB		1998	10.0 kV	15.0 kV	3300.0 A
Y3	8C01085403	ABB		1998	10.0 kV	15.0 kV	3300.0 A

Pos.	Insul. level LL	Cap. (C1)	PF (C1)	Cap. (C2)	PF (C2)	Insulation type	Tap type
H1	350 kV	266.00 pF	0.250 %	pF	%	Oil-impregnated paper	With potential tap
H2	350 kV	266.00 pF	0.230 %	pF	%	Oil-impregnated paper	With potential tap
H3	350 kV	272.00 pF	0.230 %	pF	%	Oil-impregnated paper	With potential tap
H0	110 kV	pF	%	pF	%	Oil-impregnated paper	Without tap
X1	110 kV	pF	%	pF	%	Porcelain dry type	Without tap
X2	110 kV	pF	%	pF	%	Porcelain dry type	Without tap
X3	110 kV	pF	%	pF	%	Porcelain dry type	Without tap
Y1	110 kV	pF	%	pF	%	Porcelain dry type	Without tap

Pos.	Insul. level LL	Cap. (C1)	PF (C1)	Cap. (C2)	PF (C2)	Insulation type	Tap type
Y2	110 kV	pF	%	pF	%	Porcelain dry type	Without tap
Y3	110 kV	pF	%	pF	%	Porcelain dry type	Without tap

Tap Changers nameplate data

DETC

Serial number	
Manufacturer	ABB
Manufacturer type	Manual
Winding	H
Tap scheme	1...N
No. of taps	5

Tap	Voltage
1	76125.0 V
2	74310.0 V
3	72500.0 V
4	70690.0 V
5	68875.0 V

Surge Arrester nameplate data

Surge arrester H1

Serial number	Manufacturer	Manufacturing year	Overall catalog no	Units in stack
668	CERAN	1994		1

Position	Serial No.	Voltage L-L	Voltage L-N	MCOV rating	Unit ID
1		kV	kV	kV	

Surge arrester H2

Serial number	Manufacturer	Manufacturing year	Overall catalog no	Units in stack
592	CERAN	1994		1

Position	Serial No.	Voltage L-L	Voltage L-N	MCOV rating	Unit ID
1		kV	kV	kV	

Surge arrester H3

Serial number	Manufacturer	Manufacturing year	Overall catalog no	Units in stack
588	CERAN	1994		1

Position	Serial No.	Voltage L-L	Voltage L-N	MCOV rating	Unit ID
1		kV	kV	kV	

Test set information

Model	Serial number	Calibration date
TESTRANO 600	EN907R	2023-02-20
CP TD12	EN043U	2023-02-27

Global test conditions

Weather	Partly cloudy	Humidity	100 %
---------	---------------	----------	-------

Overall PF & CAP

Ambient temperature	24 °C	Weather	Partly cloudy
Top oil temperature	30 °C	Humidity	100 %

Comments

--

Standard test**Block 1: injection at H**

Corr. temperature	30 °C
Corr. factor	0.8

No.	Meas.	Test mode	Freq.	V out	I out	Watt losses	PF meas	PF corr	Cap. meas	Assessment
1	ICH+ICHL	GSTg-B	60.00 Hz	10.00 kV	29.86 mA	950.54 mW	0.3184 %	0.2547 %	7918.1 pF	Pass
2	ICH	GSTg-A+B	60.00 Hz	10.00 kV	18.09 mA	717.34 mW	0.3966 %	0.3172 %	4795.7 pF	Pass
3	ICHL	UST-A	60.00 Hz	10.00 kV	11.77 mA	189.98 mW	0.1614 %	0.1291 %	3122.3 pF	Pass

Block 2: injection at X

Corr. temperature	30 °C
Corr. factor	0.8

No.	Meas.	Test mode	Freq.	V out	I out	Watt losses	PF meas	PF corr	Cap. meas	Assessment
4	ICL+ICLT	GSTg-A	60.00 Hz	7.00 kV	23.98 mA	722.84 mW	0.4307 %	0.3445 %	9083.9 pF	Pass
5	ICL	GSTg-A+B	60.00 Hz	7.00 kV	22.60 mA	664.07 mW	0.4197 %	0.3358 %	8563.0 pF	Pass
6	ICLT	UST-B	60.00 Hz	7.00 kV	1.37 mA	55.18 mW	0.5734 %	0.4588 %	520.9 pF	Pass

Block 3: injection at Y

Corr. temperature	30 °C
Corr. factor	0.8

No.	Meas.	Test mode	Freq.	V out	I out	Watt losses	PF meas	PF corr	Cap. meas	Assessment
7	ICT+ICTH	GSTg-A	60.00 Hz	7.00 kV	28.85 mA	1003.66 mW	0.4969 %	0.3975 %	10931.1 pF	Pass
8	ICT	GSTg-A+B	60.00 Hz	7.00 kV	20.70 mA	951.69 mW	0.6567 %	0.5253 %	7843.1 pF	Inv.
9	ICTH	UST-B	60.00 Hz	7.00 kV	8.15 mA	94.41 mW	0.1654 %	0.1323 %	3090.0 pF	Pass

Bushing H PF & CAP - C1

Ambient temperature	24 °C	Weather	Partly cloudy
Top oil temperature	30 °C	Humidity	100 %

Comments

--

Standard test

Corr. factor		1								
No.	Meas.	Test mode	Freq.	V out	I out	Watt losses	PF meas	PF corr	Cap. meas	Assessment
1	H1	UST-A	60.00 Hz	10.00 kV	1.00 mA	31.02 mW	0.3115 %	0.3115 %	264.2 pF	Pass
2	H2	UST-A	60.00 Hz	10.00 kV	0.99 mA	28.01 mW	0.2826 %	0.2826 %	263.0 pF	Pass
3	H3	UST-A	60.00 Hz	10.00 kV	1.02 mA	34.24 mW	0.3373 %	0.3373 %	269.3 pF	Pass

Bushing H PF & CAP - C2

Ambient temperature	24 °C	Weather	Partly cloudy
Top oil temperature	30 °C	Humidity	100 %

Comments

--

Standard test

No.	Meas.	Test mode	Freq.	V out	I out	Watt losses	PF meas	PF corr	Cap. meas	Assessment
1	H1	GSTg-A	60.00 Hz	2.00 kV	0.43 mA	20.40 mW	2.3837 %	2.3837 %	564.6 pF	Pass
2	H2	GSTg-A	60.00 Hz	2.00 kV	0.43 mA	19.65 mW	2.2969 %	2.2969 %	564.4 pF	Pass
3	H3	GSTg-A	60.00 Hz	2.00 kV	0.39 mA	13.75 mW	1.7601 %	1.7601 %	517.9 pF	Pass

Bushing H – Energized Collar

Ambient temperature	24 °C	Weather	Partly cloudy
Top oil temperature	30 °C	Humidity	100 %

Comments

Standard test

No.	Meas.	Test mode	Freq.	V out	I out	Watt losses	Assessment
1	H1	UST-A	60.00 Hz	12.00 kV	0.08 mA	92.55 mW	Pass
2	H2	UST-A	60.00 Hz	12.00 kV	0.08 mA	71.09 mW	Pass
3	H3	UST-A	60.00 Hz	12.00 kV	0.09 mA	67.02 mW	Pass
4	H0	UST-A	60.00 Hz	12.00 kV	0.05 mA	56.90 mW	Pass

Bushing X – Energized Collar

Ambient temperature	24 °C	Weather	Partly cloudy
Top oil temperature	30 °C	Humidity	100 %

Comments

--

Standard test

No.	Meas.	Test mode	Freq.	V out	I out	Watt losses	Assessment
1	X1	UST-A	60.00 Hz	10.00 kV	0.08 mA	53.01 mW	Pass
2	X2	UST-A	60.00 Hz	10.00 kV	0.09 mA	42.43 mW	Pass
3	X3	UST-A	60.00 Hz	10.00 kV	0.10 mA	66.31 mW	Pass

Bushing Y – Energized Collar

Ambient temperature	24 °C	Weather	Partly cloudy
Top oil temperature	30 °C	Humidity	100 %

Comments

Standard test

No.	Meas.	Test mode	Freq.	V out	I out	Watt losses	Assessment
1	Y1	UST-A	60.00 Hz	10.00 kV	0.09 mA	44.19 mW	Pass
2	Y2	UST-A	60.00 Hz	10.00 kV	0.09 mA	59.96 mW	Pass
3	Y3	UST-A	60.00 Hz	10.00 kV	0.09 mA	45.15 mW	Pass

Exciting Current

Comment

--

Measurement settings

Test voltage	5 kV
Test frequency	60.00 Hz
Tap changer under test	DETC

Averaging	2
Bandwidth	±20 Hz
AvoidTestFrequency	No

Use reference voltage	No
-----------------------	----

Measurements (sorted by tap)

Tap	Phase	V out	I out	I phase	Watt losses	Reactance	Assessment
4	A	5.00 kV	145.914 mA	-60.88 °	355.112 W	29.941 kΩ	Pass
4	B	5.00 kV	114.474 mA	-61.58 °	272.449 W	38.414 kΩ	Pass
4	C	5.00 kV	152.329 mA	-60.75 °	372.244 W	28.638 kΩ	Pass

Surge Arrester Watt Losses H

Ambient temperature	24 °C	Weather	Partly cloudy
Top oil temperature	30 °C	Humidity	100 %

Comments

--

Standard test

Meas.	Position	Test mode	Freq.	V out	I out	Watt losses	Assessment
H1	1	GST	60.00 Hz	1.00 kV	0.03 mA	1.40 mW	Pass
H2	1	GST	60.00 Hz	1.00 kV	0.03 mA	1.75 mW	Pass
H3	1	GST	60.00 Hz	1.00 kV	0.03 mA	1.93 mW	Pass

TTR H-X

Comment

--

Measurement settings

Test voltage	400 V
Test frequency	60.00 Hz
Tap changer under test	DETC

Ratio	TTR*
-------	------

Measurements (sorted by tap)

Tap	Phase	Nom. Ratio	$V_{prim} (L-L)$	I_{prim}	$V_{sec} (L-L)$	V_{phase}	TTR*	Ratio dev	Assessment
4	A	2.9575	393.02 V	9.078 mA	76.79 V	30.91 °	2.9552	-0.08 %	Pass
4	B	2.9575	403.85 V	8.760 mA	77.57 V	29.66 °	3.0059	1.64 %	Pass
4	C	2.9575	399.91 V	6.239 mA	78.89 V	29.43 °	2.9266	-1.04 %	Pass

TTR H-Y

Comment

--

Measurement settings

Test voltage	400 V
Test frequency	60.00 Hz
Tap changer under test	DETC

Ratio	TTR*
-------	------

Measurements (sorted by tap)

Tap	Phase	Nom. Ratio	$V_{prim} (L-L)$	I_{prim}	$V_{sec} (L-L)$	V_{phase}	TTR*	Ratio dev	Assessment
4	A	2.9575	392.59 V	9.096 mA	76.71 V	30.97 °	2.9548	-0.09 %	Pass
4	B	2.9575	404.11 V	8.750 mA	77.55 V	29.64 °	3.0087	1.73 %	Pass
4	C	2.9575	399.91 V	6.256 mA	78.96 V	29.4 °	2.9243	-1.12 %	Pass

DC Winding Resistance H

Comment

--

Measurement settings

Test current	5 A
Output mode	16 A @ 340 V
	1 ph.
Measurement	L-N

Tap changer under test	DETC
------------------------	------

Winding temperature	20 °C
Reference temperature	75 °C
Temp. corr. factor (K)	1.216

Automatic result	True
Settling time (At)	5 s
Tolerance R dev	0.1 %
Recording time	200.0 ms

Tap	A (H1 - H0)			B (H2 - H0)			C (H3 - H0)		
	<i>R meas</i>	<i>R dev</i>	<i>R corr</i>	<i>R meas</i>	<i>R dev</i>	<i>R corr</i>	<i>R meas</i>	<i>R dev</i>	<i>R corr</i>
4	58.083 mΩ	0.070 %	70.636 mΩ	57.601 mΩ	0.016 %	70.049 mΩ	58.595 mΩ	0.067 %	71.258 mΩ

DC Winding Resistance X

Comment

Measurement settings

Test current	10 A
Output mode	16 A @ 340 V
	1 ph.

Automatic result	True
Settling time (At)	5 s
Tolerance R dev	0.1 %
Recording time	200.0 ms

A (X1 - X2)			B (X2 - X3)			C (X3 - X1)		
<i>R meas</i>	<i>R dev</i>	<i>R corr</i>	<i>R meas</i>	<i>R dev</i>	<i>R corr</i>	<i>R meas</i>	<i>R dev</i>	<i>R corr</i>
5.130 mΩ	0.354 %	5.130 mΩ	5.072 mΩ	0.577 %	5.072 mΩ	4.984 mΩ	0.338 %	4.984 mΩ

DC Winding Resistance Y

Comment

--

Measurement settings

Test current	10 A
Output mode	16 A @ 340 V
	1 ph.

Automatic result	True
Settling time (At)	5 s
Tolerance R dev	0.1 %
Recording time	200.0 ms

A (Y1 - Y2)			B (Y2 - Y3)			C (Y3 - Y1)		
<i>R meas</i>	<i>R dev</i>	<i>R corr</i>	<i>R meas</i>	<i>R dev</i>	<i>R corr</i>	<i>R meas</i>	<i>R dev</i>	<i>R corr</i>
4.907 mΩ	0.072 %	4.907 mΩ	4.903 mΩ	0.988 %	4.903 mΩ	4.871 mΩ	0.459 %	4.871 mΩ

Insulation Resistance

Comment

Test object temperature	50 °C
Reference temperature	20 °C

Ambient temperature	24 °C
Humidity	100 %

PI calculation	
Time 1	60 s
Time 2	600 s

DAR calculation	
Time 1	30 s
Time 2	60 s

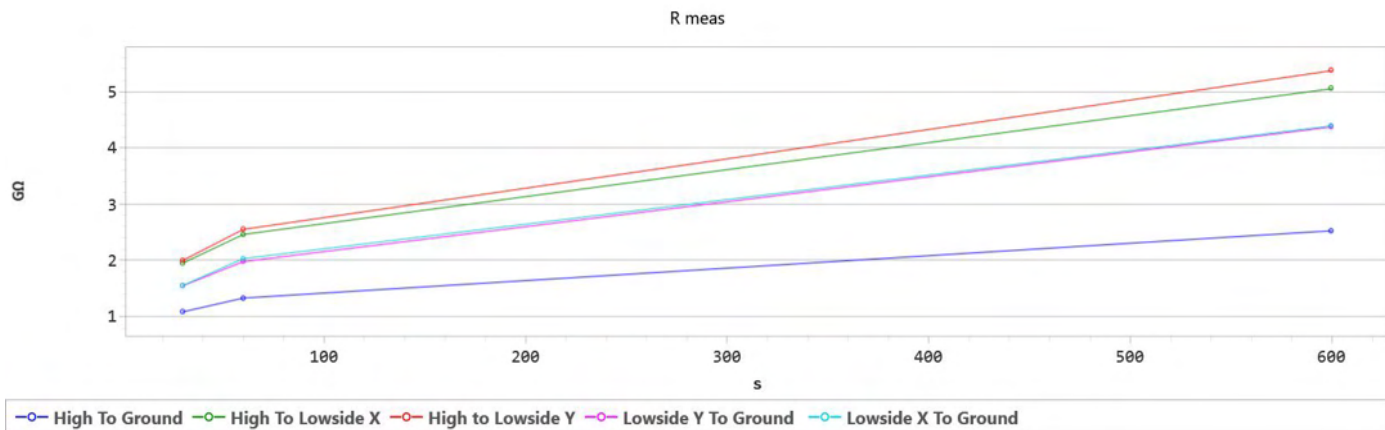

Name High To Ground				
PI	1.90	<input checked="" type="checkbox"/>	DAR	1.23 <input checked="" type="checkbox"/>

Time	R meas	R corr	V DC	I DC
30 s	1.084 GΩ	1.084 GΩ	10.00 kV	9.225 μA
60 s	1.329 GΩ	1.329 GΩ	10.00 kV	7.524 μA
600 s	2.525 GΩ	2.525 GΩ	10.00 kV	3.960 μA

Name High To Lowside X				
PI	2.05	<input checked="" type="checkbox"/>	DAR	1.26 <input checked="" type="checkbox"/>

Time	R meas	R corr	V DC	I DC
30 s	1.950 GΩ	1.950 GΩ	10.00 kV	5.128 μA
60 s	2.460 GΩ	2.460 GΩ	10.00 kV	4.065 μA
600 s	5.050 GΩ	5.050 GΩ	10.00 kV	1.980 μA

Name High to Lowside Y				
PI	2.11	<input checked="" type="checkbox"/>	DAR	1.28 <input checked="" type="checkbox"/>

Time	R meas	R corr	V DC	I DC
30 s	1.999 GΩ	1.999 GΩ	10.00 kV	5.003 μA
60 s	2.550 GΩ	2.550 GΩ	10.00 kV	3.922 μA
600 s	5.370 GΩ	5.370 GΩ	10.00 kV	1.862 μA

Name Lowside Y To Ground				
PI	2.21	<input checked="" type="checkbox"/>	DAR	1.28 <input checked="" type="checkbox"/>

Time	R meas	R corr	V DC	I DC
30 s	1.548 GΩ	1.548 GΩ	10.00 kV	6.460 μA
60 s	1.977 GΩ	1.977 GΩ	10.00 kV	5.058 μA
600 s	4.370 GΩ	4.370 GΩ	10.00 kV	2.288 μA

Name Lowside X To Ground				
PI	2.16	<input checked="" type="checkbox"/>	DAR	1.31 <input checked="" type="checkbox"/>

Time	R meas	R corr	V DC	I DC
30 s	1.552 GΩ	1.552 GΩ	10.00 kV	6.443 μA
60 s	2.030 GΩ	2.030 GΩ	10.00 kV	4.926 μA
600 s	4.390 GΩ	4.390 GΩ	10.00 kV	2.278 μA

2B - Dry Type Transformer



Client	Orange Cogen	OCFL2310066 - 2B - Dry Type	
Execution date	9/30/2023	Reason of the job	
Tested by	Matthew Falchetti	Location	Orange Cogen
Approved by		Asset	Transformer
Report ID	2	Asset type	Two-winding
Report issue date	10/13/2023 9:10:24 AM	Asset serial number	24-34785-01 1B
Work order		Manufacturer	ABB

Summary

Performed tests	Assessment
Overall PF & CAP	Pass
TTR H-X	Pass
DC Winding Resistance H	Pass
DC Winding Resistance X	Pass
Insulation Resistance	Pass

Overall Assessment	No Faults
--------------------	-----------

Tested by:
Andrew Kirk

Approved by:
Matthew Falchetti

Location & company information			
Location		Company	
Name	Orange Cogen	Company	HVA – P&C / Field Service
Region		Department	South
Division	South	Address	
Area		City	Lakeland
Plant	Orange Cogen	State/Province	Florida
Address	1901 S. Clear Springs Rd	Postal code	33811
City	Bartow	Country	United States
State/Province	Florida	Phone No.	
Postal code	33830	Fax No.	
Country	United States	E-mail	

Geo coordinates	
-----------------	--

Contact person	
Name	
Phone No. 1	
Phone No. 2	
Fax No.	
E-mail	

Comment

Transformer nameplate data			
Serial number	24-34785-01 1B	Apparatus ID	Transformer 1B
Manufacturer	ABB	Feeder	
Manufacturing year	1994	No. phases	3
Manufacturer type	Vent	Vector group	Dyn1

Comment

Voltage ratings			
Winding	Voltage L-L	Voltage L-N	Insul. level L-L
H	4.056 kV	kV	60 kV
X	0.480 kV	0.277 kV	10 kV

Power ratings		
Rated power	Cooling class	Temp. rise wind.
2.500 MVA	OA	

Current ratings at rated power		
Winding		
H	X	Rated power
A	A	2.500 MVA

Short-circuit rating		
Max. short-circuit current	kA	s

Impedances	
Ref. temp.	75 °C

Leakage reactance H - X

Zk[%]	Base power	Base voltage	Load losses Pk	OLTC position	DETC position
%	MVA	kV	W		

Zero sequence impedance

Base power	MVA
Base voltage	kV
Description	Z0[%]
Secondary	%

Others

Category	Distribution
Status	In operation
Tank type	n/a
Insulation medium	Dry type
Fluid insulation volume	gals
Fluid insulation weight	lbs
Total weight	lbs

Bushings nameplate data

Pos.	Serial No.	Manufact.	Manufacturer type	Man. year	Voltage L-ground	Max. system voltage	Rated current
H1					kV	kV	A
H2					kV	kV	A
H3					kV	kV	A
X1					kV	kV	A
X2					kV	kV	A
X3					kV	kV	A
X0					kV	kV	A

Pos.	Insul. level LL	Cap. (C1)	PF (C1)	Cap. (C2)	PF (C2)	Insulation type	Tap type
H1	V	pF	%	pF	%		
H2	V	pF	%	pF	%		
H3	V	pF	%	pF	%		
X1	V	pF	%	pF	%		
X2	V	pF	%	pF	%		
X3	V	pF	%	pF	%		
X0	V	pF	%	pF	%		

Tap Changers nameplate data**DETC**

Serial number	
Manufacturer	
Manufacturer type	Manual
Winding	H
Tap scheme	1...N
No. of taps	5

Tap	Voltage
1	4638.0 V
2	4264.0 V
3	4160.0 V

Tap	Voltage
4	4056.0 V
5	3952.0 V

Test set information		
-----------------------------	--	--

Model	Serial number	Calibration date
TESTRANO 600	EN907R	2023-02-20
CP TD12	EN043U	2023-02-27

Global test conditions			
-------------------------------	--	--	--

Weather		Humidity	%
Unit location		Ambient temperature	°C

Overall PF & CAP			
Ambient temperature	°C	Weather	
Top oil temperature	°C	Humidity	%

Comments

Standard test

Block 1: injection at H

Corr. temperature	°C
Corr. factor	1

No.	Meas.	Test mode	Freq.	V out	I out	Watt losses	PF meas	PF corr	Cap. meas	Assessment
1	ICH+ICHL	GST	60.00 Hz	2.00 kV	3.18 mA	4704.33 mW	0.5308 %	0.5308 %	2843.0 pF	Pass
2	ICH	GSTg-A	60.00 Hz	2.00 kV	1.87 mA	3550.68 mW	0.6913 %	0.6913 %	785.5 pF	Pass
3	ICHL	UST-A	60.00 Hz	2.00 kV	1.65 mA	1099.94 mW	0.4039 %	0.4039 %	2058.0 pF	Pass

Block 2: injection at X

Corr. temperature	°C
Corr. factor	1

No.	Meas.	Test mode	Freq.	V out	I out	Watt losses	PF meas	PF corr	Cap. meas	Assessment
4	ICL+ICLH	GST	60.00 Hz	0.10 kV	0.42 mA	36.91 mW	0.3438 %	0.3438 %	5445.7 pF	Pass
5	ICL	GSTg-A	60.00 Hz	0.10 kV	0.36 mA	33.78 mW	0.4583 %	0.4583 %	3410.0 pF	Pass
6	ICLH	UST-A	60.00 Hz	0.10 kV	0.08 mA	2.58 mW	0.6654 %	0.6654 %	2031.0 pF	Pass

TTR H-X

Comment

--

Measurement settings

Test voltage	120 V
Test frequency	60.00 Hz
Tap changer under test	DETC

Ratio	TTR*
-------	------

Measurements (sorted by tap)

Tap	Phase	Nom. Ratio	$V_{prim} (L-L)$	I_{prim}	$V_{sec} (L-L)$	V_{phase}	TTR*	Ratio dev	Assessment
4	A	14.6358	119.93 V	132.891 mA	14.16 V	330.01 °	14.6710	0.24 %	Pass
4	B	14.6358	119.93 V	87.733 mA	14.16 V	330.01 °	14.6705	0.24 %	Pass
4	C	14.6358	119.92 V	91.704 mA	14.16 V	330.01 °	14.6718	0.25 %	Pass

DC Winding Resistance H

Comment

--

Measurement settings

Test current	10 A	Tap changer under test	DETC
Output mode	33 A @ 170 V		
	1 ph.		

Automatic result	True
Settling time (At)	5 s
Tolerance R dev	0.1 %
Recording time	200.0 ms

Tap	A (H1 - H3)			B (H2 - H1)			C (H3 - H2)		
	<i>R meas</i>	<i>R dev</i>	<i>R corr</i>	<i>R meas</i>	<i>R dev</i>	<i>R corr</i>	<i>R meas</i>	<i>R dev</i>	<i>R corr</i>
4	35.624 mΩ	0.001 %	35.624 mΩ	35.578 mΩ	0.001 %	35.578 mΩ	35.697 mΩ	0.002 %	35.697 mΩ

DC Winding Resistance X

Comment

--

Measurement settings

Test current	10 A
Output mode	33 A @ 170 V
	1 ph.
Measurement	L-N

A (X1 - X0)			B (X2 - X0)			C (X3 - X0)		
<i>R meas</i>	<i>R dev</i>	<i>R corr</i>	<i>R meas</i>	<i>R dev</i>	<i>R corr</i>	<i>R meas</i>	<i>R dev</i>	<i>R corr</i>
254.627 $\mu\Omega$	0.007 %	254.627 $\mu\Omega$	247.770 $\mu\Omega$	0.006 %	247.770 $\mu\Omega$	262.773 $\mu\Omega$	0.004 %	262.773 $\mu\Omega$

Insulation Resistance

Comment

Test object temperature	°C
Reference temperature	20 °C

Ambient temperature	°C
Humidity	%

PI calculation	
Time 1	60 s
Time 2	600 s

DAR calculation	
Time 1	30 s
Time 2	60 s

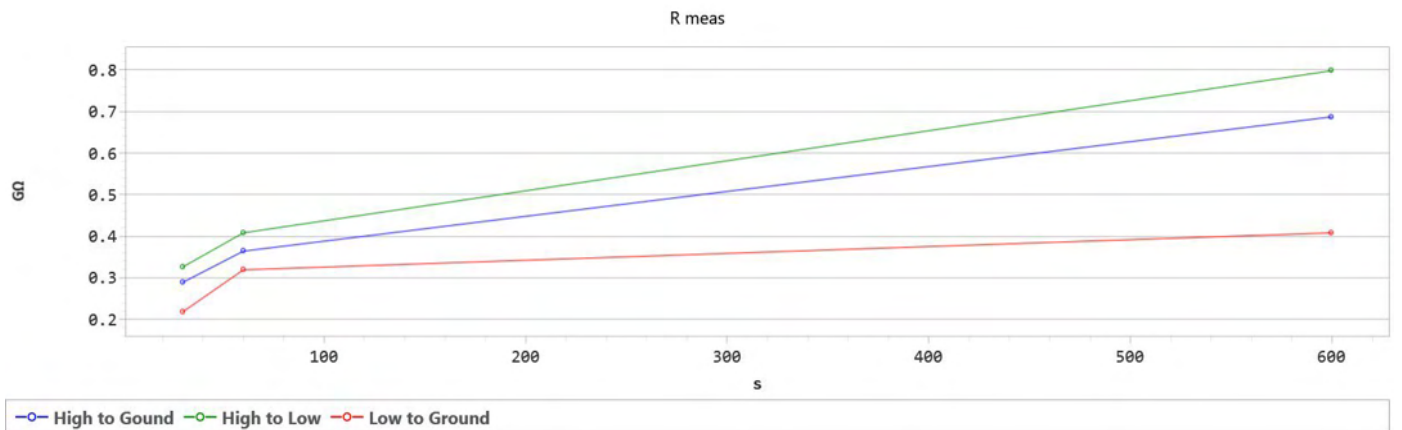

Name High to Gound				
PI	1.89	<input checked="" type="checkbox"/>	DAR	1.26 <input checked="" type="checkbox"/>

Time	R meas	R corr	V DC	I DC
30 s	289.000 MΩ	289.000 MΩ	5.00 kV	17.301 μA
60 s	364.000 MΩ	364.000 MΩ	5.00 kV	13.736 μA
600 s	687.000 MΩ	687.000 MΩ	5.00 kV	7.278 μA

Name High to Low				
PI	1.96	<input checked="" type="checkbox"/>	DAR	1.25 <input checked="" type="checkbox"/>

Time	R meas	R corr	V DC	I DC
30 s	326.000 MΩ	326.000 MΩ	5.00 kV	15.337 μA
60 s	408.000 MΩ	408.000 MΩ	5.00 kV	12.255 μA
600 s	798.000 MΩ	798.000 MΩ	5.00 kV	6.266 μA

Name Low to Ground				
PI	1.28	<input checked="" type="checkbox"/>	DAR	1.46 <input checked="" type="checkbox"/>

Time	R meas	R corr	V DC	I DC
30 s	218.000 MΩ	218.000 MΩ	500.00 V	2.294 μA
60 s	319.000 MΩ	319.000 MΩ	500.00 V	1.567 μA
600 s	408.000 MΩ	408.000 MΩ	500.00 V	1.225 μA

52 - T2 - SF-6 Breaker



Client	Orange Cogen	OCFL2310066 - 52 - T2	
Execution date	10/4/2023	Reason of the job	Routine
Tested by	Matthew Falchetti	Location	Orange Cogen
Approved by		Asset	Circuit breaker
Report ID	2	Asset type	Dead tank SF6 breaker
Report issue date	10/13/2023 9:02:29 AM	Asset serial number	48325-1
Work order		Manufacturer	Siemens

Summary
DLRO Readings - Closed Breaker A - phase - 112 micro B - phase - 110 micro C - phase - 110 micro

Performed tests	Assessment
C Timing	Pass
O Timing	Pass
CO Timing	Pass
OC Timing	Pass
O-CO Timing	Pass
Insulation Resistance	Pass

Overall Assessment	No Faults
--------------------	-----------

Tested by:
Andrew Kirk

Approved by:
Matthew Falchetti

Location & company information

Location	
Name	Orange Cogen
Region	
Division	South
Area	
Plant	Orange Cogen
Address	1901 S. Clear Springs Rd
City	Bartow
State/Province	Florida
Postal code	33830
Country	United States

Company	
Company	HVA – P&C / Field Services
Department	South
Address	
City	Lakeland
State/Province	Florida
Postal code	33811
Country	United States
Phone No.	
Fax No.	
E-mail	

Geo coordinates	
-----------------	--

Contact person	
Name	
Phone No. 1	
Phone No. 2	
Fax No.	
E-mail	

Comment

Dead tank SF6 breaker nameplate data

Serial number	48325-1
Manufacturer	Siemens
Manufacturing year	1994
Manufacturer type	SPS-72.5-40-1
Asset system code	
Apparatus ID	52-T2
Feeder	
No. of phases	3

No. of interrupters p. phase	1
Pole operation	Ganged
Pre-insertion resistors	No
PIR value	Ω
Grading capacitors	Yes
Capacitor value	pF
Interrupting medium	SF6
Tank type	Dead tank

Comment

Ratings

Rated frequency	60.00 Hz
Rated voltage L-L	72.5 kV
Rated current	2000.0 A
Rated SC breaking current	40.0 kA
Short-circuit nominal duration	s
Rated insul. level L-G (BIL)	350.0 kV
Rated interrupting time	ms
Interrupting duty cycle	
Rated power at closing	W
Rated power at opening	W
Rated power at motor charge	W

Contact system

Total travel	in
Damping time	ms
Nozzle length	in

Others

Total weight with gas	4370 lbs
Weight of gas	15 lbs
Volume of gas	gals
Rated gas pressure	80.00 psi @ 21 °C

Spring Operating mechanism nameplate data

Serial No.	48325-1
Manufacturer	Siemens
Manufacturer type	SPS-SE
Manufacturing year	1994
Asset system code	52 -T2

Component	Rated voltage	Rated current	Frequency	
Trip coil 1	135.0 V	A	Hz	DC
Close coil 1	135.0 V	A	Hz	DC
Auxiliary circuits	V	A	Hz	DC
Motor	135.0 V	A	Hz	DC

Bushings nameplate data

Pos.	Serial No.	Manufact.	Man. year	Voltage L-ground	Max. system voltage	Rated current	Insul. level LL
1		LAPP		72.5 kV	72.5 kV	2000.0 A	V
2		LAPP		72.5 kV	72.5 kV	2000.0 A	V
3		LAPP		72.5 kV	72.5 kV	2000.0 A	V
4		LAPP		72.5 kV	72.5 kV	2000.0 A	V
5		LAPP		72.5 kV	72.5 kV	2000.0 A	V
6		LAPP		72.5 kV	72.5 kV	2000.0 A	V

Pos.	Cap. (C1)	PF (C1)	Cap. (C2)	PF (C2)	Insulation type	Tap type
1	pF	%	pF	%	Porcelain dry type	Without tap

Pos.	Cap. (C1)	PF (C1)	Cap. (C2)	PF (C2)	Insulation type	Tap type
2	pF	%	pF	%	Porcelain dry type	Without tap
3	pF	%	pF	%	Porcelain dry type	Without tap
4	pF	%	pF	%	Porcelain dry type	Without tap
5	pF	%	pF	%	Porcelain dry type	Without tap
6	pF	%	pF	%	Porcelain dry type	Without tap

Test set information

Model	Serial number	Calibration date
CIBANO 500	BM271E	2023-07-06
CB TN3	AL015E	2023-07-05

Global test conditions

Weather	Clear	Humidity	100 %
Unit location	Outside	Ambient temperature	23 °C

Operations counter

Counter reading found	39
Counter reading left	

C Timing

Execution date/Time	10/4/2023 11:28:46 AM	
Sequence	C	
Coil supply voltage	135.0 V DC	
Time calculation	According to IEC 62271-100	
Sample rate	10 kHz	

Transducer settings

CB TN3, Channel 1	5.0 V - 0.0125 ° (digital)
-------------------	----------------------------

Main, resistive and auxiliary contacts

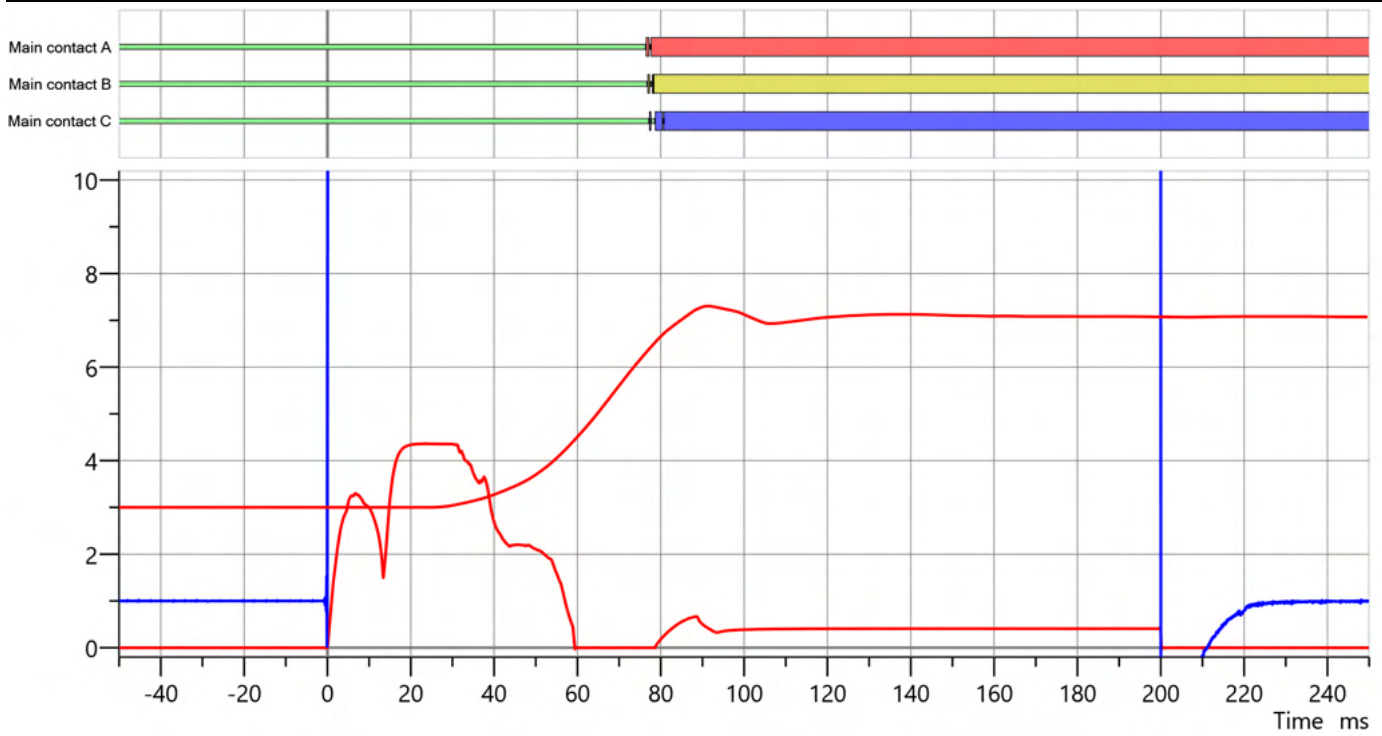

Label	Unit/div.	Y-Axis pos.	Label	Unit/div.	Y-Axis pos.		
Close coil (A)	■	1.00 A	0.00	Channel 1 (travel)	■	7.85 °	3.00
Close coil (V)	■	10.00 V	1.00				

Operating times

Meas.	Closing time (ms)	Closing sync. (ms)	Assessment
Breaker	77.20	0.80	Pass
A	76.40		Pass
Main contact A	76.40		Pass
B	76.80		Pass
Main contact B	76.80		Pass
C	77.20		Pass
Main contact C	77.20		Pass

Assessment Limits	t min	t max
Closing time	70.00 ms	90.00 ms
Closing sync. (contacts within a phase)	ms	ms
Closing sync. (between breaker phases)	ms	ms

Contact travel characteristics

Module	Channel	Total travel	Over-travel	Rebound	Damping dist. BLG	Damping time BLG	Assessment
CB TN3	Channel 1	31.98 °	1.81 °	1.11 °	°	ms	N. rated

Assessment Limits	d min	d max
Total travel, TT	in	in
Over-travel (Close), OT	in	in
Rebound (Close), RB	in	in
Contact wipe (Close), CW	in	in

Assessment Limits	Minimum	Maximum
Damping distance (Close)	in	in
Damping time (Close)	ms	ms

Main contact characteristics

Main contact	Travel data	Contact wipe	Reaction time	PIR close time	Bounce time	Bounce count	Assessment
Main contact A	Channel 1	6.03 °	29.90 ms	ms	1.20 ms	1	N. rated
Main contact B	No data		ms	ms	1.40 ms	2	N. rated
Main contact C	No data		ms	ms	3.40 ms	2	N. rated

Assessment Limits	Minimum	Maximum
Bounce time	ms	ms
Bounce count		
Reaction time	ms	ms

Coil characteristics

	Peak current (A)	Average current (A)	Average voltage (V)	Resistance (Ω)	Assessment
Close	4.37	3.19	132.09	41.39	N. rated

Assessment Limits	Minimum	Maximum
Peak close coil current	A	A
Peak trip coil current	A	A
Average close coil current	A	A
Average trip coil current	A	A
Average close coil voltage	V	V
Average trip coil voltage	V	V
Close coil resistance	Ω	Ω
Trip coil resistance	Ω	Ω

O Timing

Execution date/Time	10/4/2023 11:27:04 AM	
Sequence	O	
Coil supply voltage	135.0 V DC	
Time calculation	According to IEC 62271-100	
Sample rate	10 kHz	

Transducer settings

CB TN3, Channel 1	5.0 V - 0.0125 ° (digital)
-------------------	----------------------------

Main, resistive and auxiliary contacts

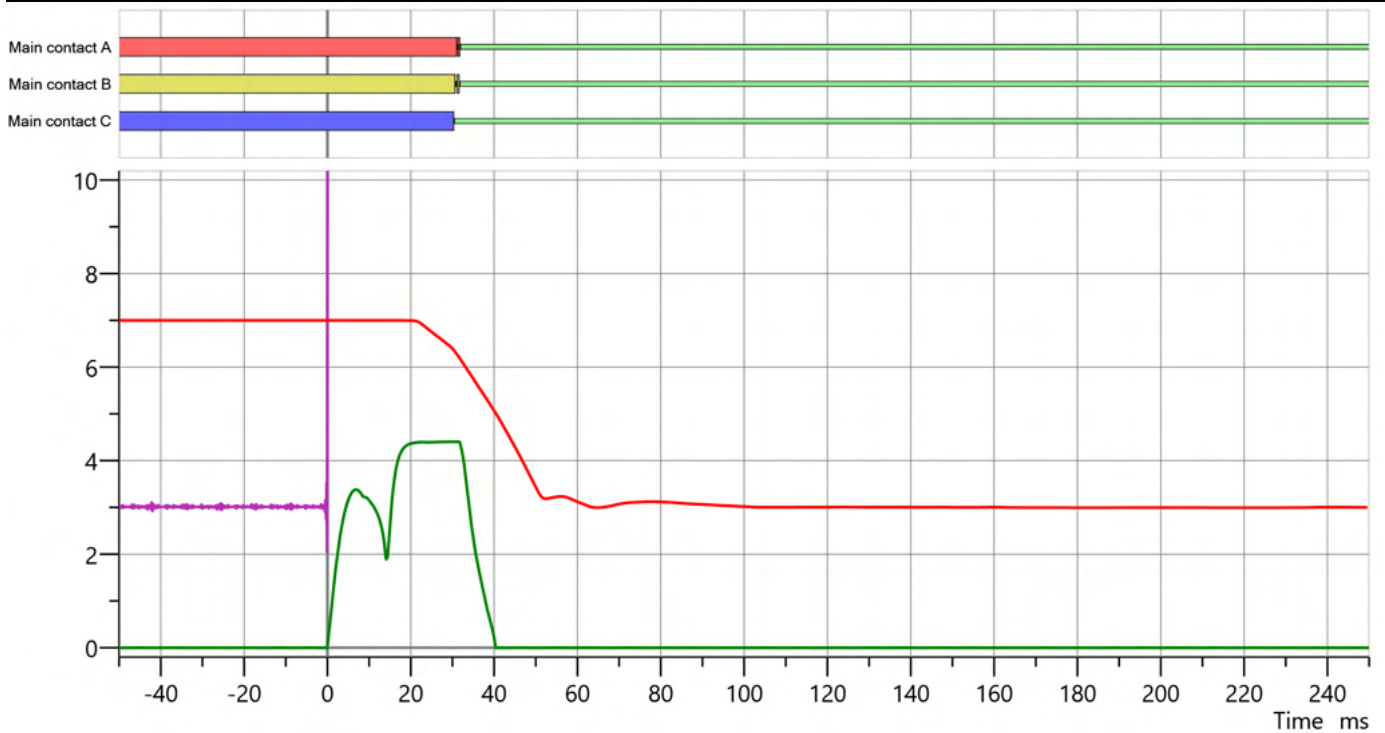

Label	Unit/div.	Y-Axis pos.	Label	Unit/div.	Y-Axis pos.
Trip coil (A)	■ 1.00 A	0.00	Channel 1 (travel)	■ 7.87 °	2.99
Trip coil (V)	■ 10.00 V	3.00			

Operating times

Meas.	Opening time (ms)	Opening sync. (ms)	Assessment
Breaker	31.90	1.50	Pass
A	31.90		Pass
Main contact A	31.90		Pass
B	31.70		Pass
Main contact B	31.70		Pass
C	30.40		Pass
Main contact C	30.40		Pass

Assessment Limits	t min	t max
Opening time	ms	32.00 ms
Opening sync. (contacts within a phase)	ms	ms
Opening sync. (between breaker phases)	ms	ms

Contact travel characteristics

Module	Channel	Total travel	Over-travel	Rebound	Damping distance	Assessment
CB TN3	Channel 1	31.46 °	0.06 °	0.95 °	°	N. rated

Assessment Limits	d min	d max
Total travel, TT	in	in
Over-travel (Trip), OT	in	in
Rebound (Trip), RB	in	in
Contact wipe (Trip), CW	in	in

Assessment Limits	Minimum	Maximum
Damping distance (Trip)	in	in

Main contact characteristics

Main contact	Travel data	Contact wipe	Reaction time	PIR close time	Bounce time	Bounce count	Assessment
Main contact A	Channel 1	6.55 °	22.00 ms	ms	0.80 ms	1	N. rated
Main contact B	No data		ms	ms	1.00 ms	1	N. rated
Main contact C	No data		ms	ms	0.00 ms	0	N. rated

Assessment Limits	Minimum	Maximum
Bounce time	ms	ms
Bounce count		
Reaction time	ms	ms

Coil characteristics

	Peak current (A)	Average current (A)	Average voltage (V)	Resistance (Ω)	Assessment
Trip A	4.40	3.52	131.98	37.46	N. rated

Assessment Limits	Minimum	Maximum
Peak close coil current	A	A
Peak trip coil current	A	A
Average close coil current	A	A
Average trip coil current	A	A
Average close coil voltage	V	V
Average trip coil voltage	V	V
Close coil resistance	Ω	Ω
Trip coil resistance	Ω	Ω

CO Timing

Execution date/Time	10/4/2023 11:28:07 AM	
Sequence	CO	
Coil supply voltage	135.0 V DC	
Sample rate	10 kHz	

Transducer settings

CB TN3, Channel 1	5.0 V - 0.0125 ° (digital)
-------------------	----------------------------

Main, resistive and auxiliary contacts

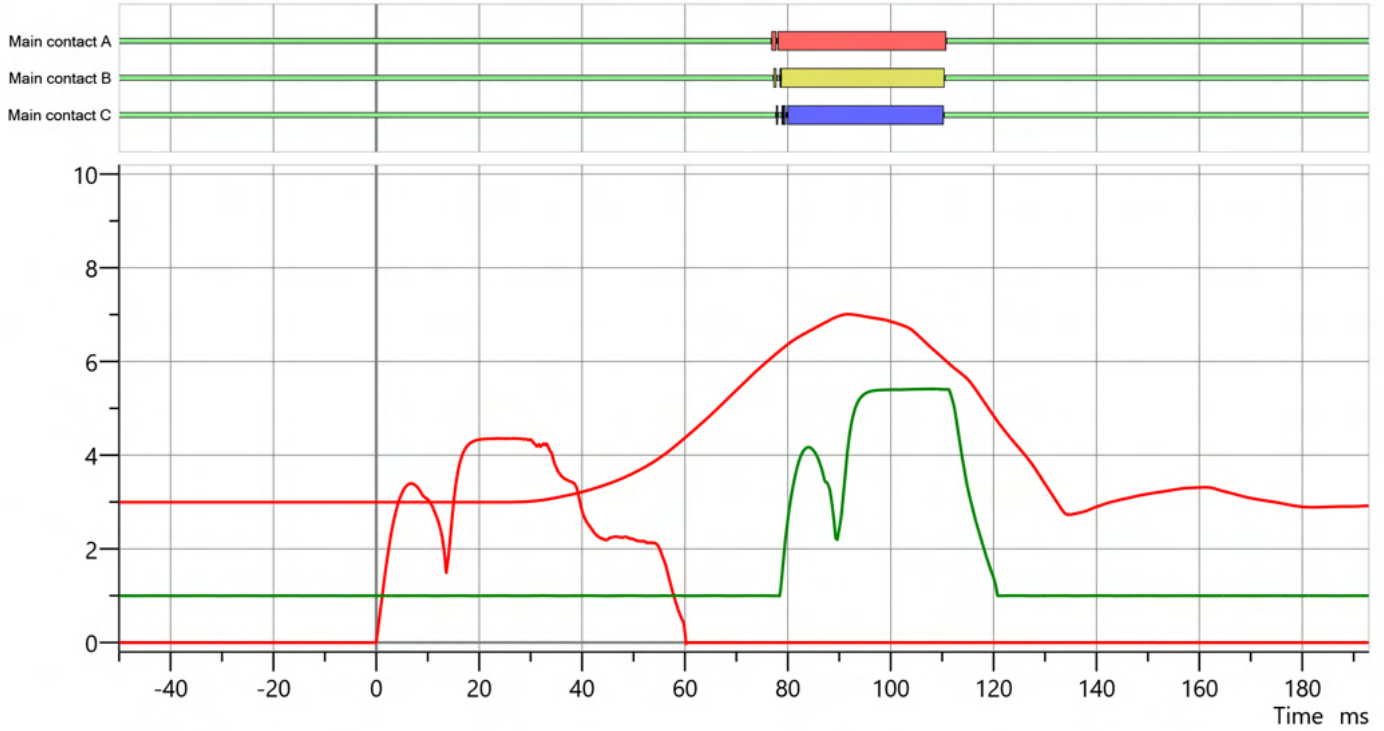

Label	Unit/div.	Y-Axis pos.	Label	Unit/div.	Y-Axis pos.		
Close coil (A)	■	1.00 A	0.00	Channel 1 (travel)	■	8.31 °	2.73
Trip coil (A)	■	1.00 A	1.00				

Operating times

Meas.	Closing time (ms)	Closing sync. (ms)	Close-Open time 1 (ms)	Assessment
Breaker	77.70	0.90	34.00	Pass
A	76.80		34.00	Pass
Main contact A	76.80		34.00	Pass
B	77.20		33.30	Pass
Main contact B	77.20		33.30	Pass
C	77.70		32.60	Pass
Main contact C	77.70		32.60	Pass

Assessment Limits	t min	t max
Closing time	70.00 ms	90.00 ms
Closing sync. (contacts within a phase)	ms	ms
Closing sync. (between breaker phases)	ms	ms
Close-Open time	ms	ms

Coil characteristics

	Peak current (A)	Average current (A)	Average voltage (V)	Resistance (Ω)	Assessment
Close	4.36				N. rated
Trip A	4.41				N. rated

Assessment Limits	Minimum	Maximum
Peak close coil current	A	A
Peak trip coil current	A	A

Comments

OC Timing

Execution date/Time	10/4/2023 11:30:52 AM	
Sequence	OC	
Coil supply voltage	135.0 V DC	
Sample rate	10 kHz	

Transducer settings

CB TN3, Channel 1	5.0 V - 0.0125 ° (digital)
-------------------	----------------------------

Main, resistive and auxiliary contacts

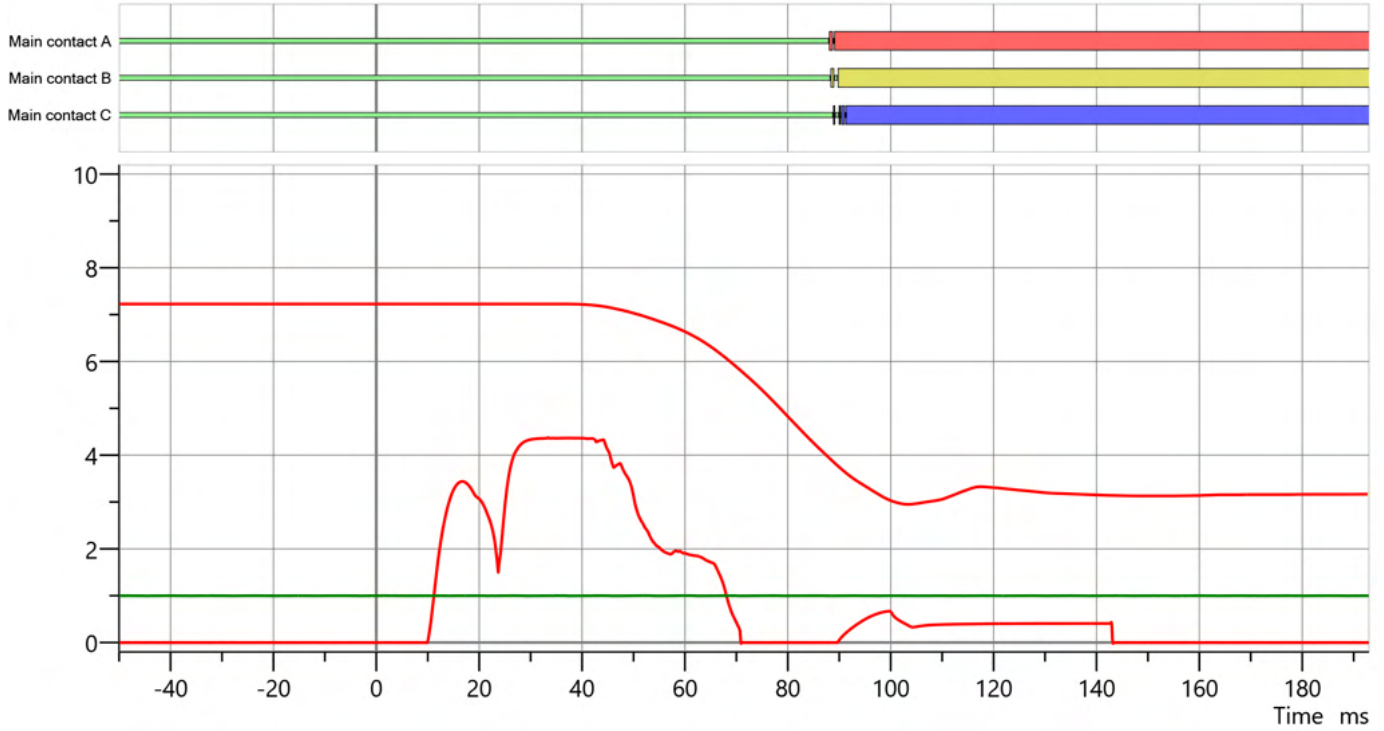

Label	Unit/div.	Y-Axis pos.	Label	Unit/div.	Y-Axis pos.		
Close coil (A)	■	1.00 A	0.00	Channel 1 (travel)	■	7.82 °	2.95
Trip coil (A)	■	1.00 A	1.00				

Operating times

Meas.	Opening time (ms)	Opening sync. (ms)	Reclosing time (ms)	Assessment
Breaker				N. rated
A				N. rated
Main contact A				N. rated
B				N. rated
Main contact B				N. rated
C				N. rated
Main contact C				N. rated

Assessment Limits	t min	t max
Opening time	ms	32.00 ms
Opening sync. (contacts within a phase)	ms	ms
Opening sync. (between breaker phases)	ms	ms
Reclosing time	ms	200.00 ms

Coil characteristics

	Peak current (A)	Average current (A)	Average voltage (V)	Resistance (Ω)	Assessment
Close	4.38				N. rated
Trip A	0.00				N. rated

Assessment Limits	Minimum	Maximum
Peak close coil current	A	A
Peak trip coil current	A	A

Comments

O-CO Timing

Execution date/Time	10/4/2023 11:31:32 AM	
Sequence	O-CO	
Coil supply voltage	135.0 V DC	
Sample rate	10 kHz	

Transducer settings

CB TN3, Channel 1	5.0 V - 0.0125 ° (digital)
-------------------	----------------------------

Main, resistive and auxiliary contacts

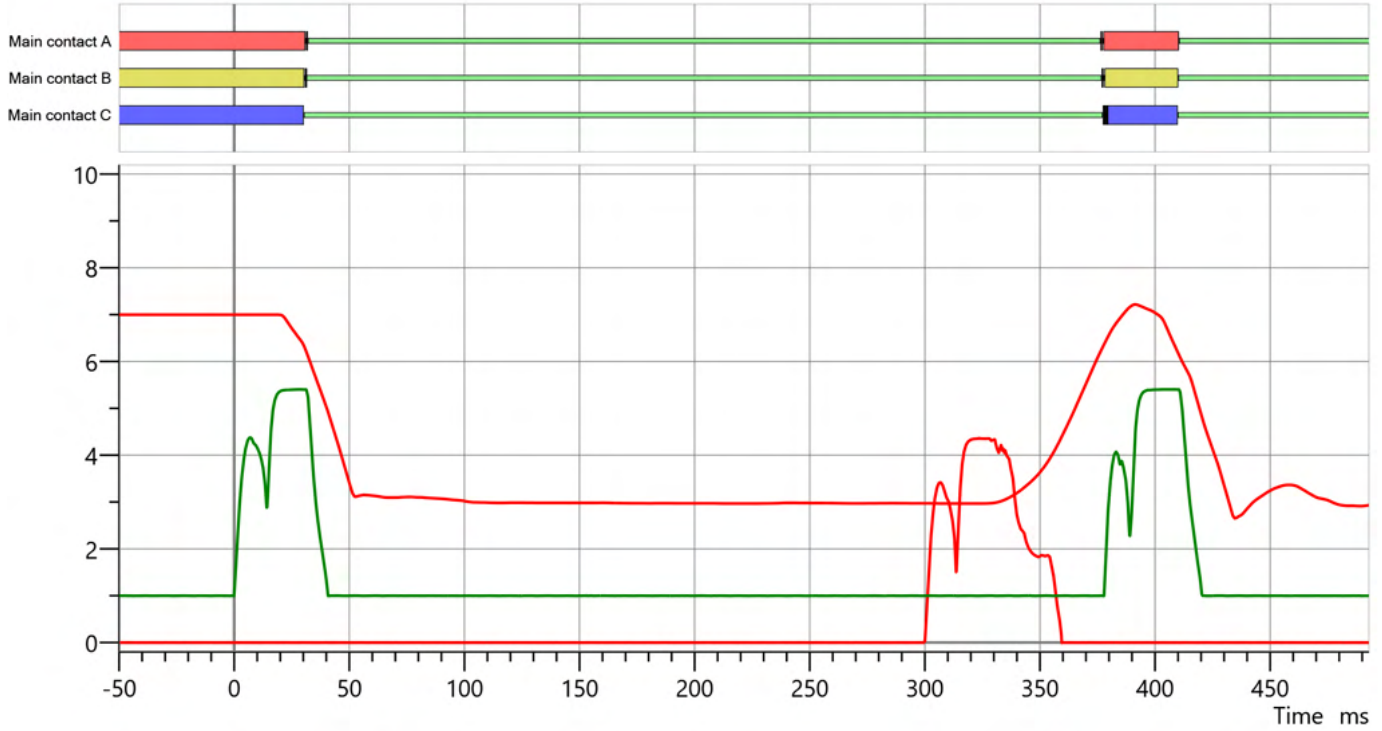

Label	Unit/div.	Y-Axis pos.	Label	Unit/div.	Y-Axis pos.		
Close coil (A)	■	1.00 A	0.00	Channel 1 (travel)	■	7.89 °	2.65
Trip coil (A)	■	1.00 A	1.00				

Operating times

Meas.	Opening time (ms)	Opening sync. (ms)	Closing time (ms)	Closing sync. (ms)	Open-Close time (ms)	Close-Open time 1 (ms)	Assessment
Breaker	32.00	1.80	77.30	1.00	344.30	34.10	Pass
A	32.00		76.30		344.30	34.10	Pass
Main contact A	32.00		76.30		344.30	34.10	Pass
B	31.30		76.80		345.50	33.30	Pass
Main contact B	31.30		76.80		345.50	33.30	Pass
C	30.20		77.30		347.10	32.60	Pass
Main contact C	30.20		77.30		347.10	32.60	Pass

Assessment Limits	t min	t max
Opening time	ms	32.00 ms
Opening sync. (contacts within a phase)	ms	ms
Opening sync. (between breaker phases)	ms	ms
Closing time	70.00 ms	90.00 ms
Closing sync. (contacts within a phase)	ms	ms
Closing sync. (between breaker phases)	ms	ms
Open-Close time	ms	ms
Close-Open time	ms	ms

Coil characteristics

	Peak current (A)	Average current (A)	Average voltage (V)	Resistance (Ω)	Assessment
Close	4.36				N. rated
Trip A	4.40				N. rated

Assessment Limits	Minimum	Maximum
Peak close coil current	A	A
Peak trip coil current	A	A

Comments

Insulation Resistance

Comment

Test object temperature	°C
Reference temperature	20 °C

Ambient temperature	23 °C
Humidity	100 %

PI calculation	
Time 1	60 s
Time 2	600 s

DAR calculation	
Time 1	30 s
Time 2	60 s

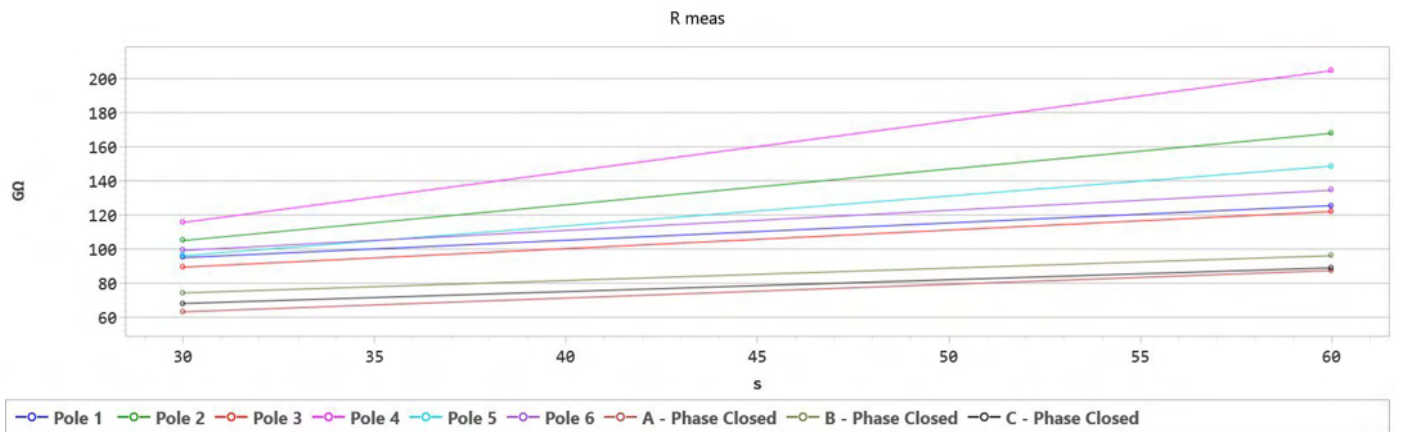

Name Pole 1				
PI		NaN	DAR	1.32

Time	R meas	R corr	V DC	I DC
30 s	95.200 GΩ	95.200 GΩ	5.00 kV	52.521 nA
60 s	125.700 GΩ	125.700 GΩ	5.00 kV	39.777 nA

Name Pole 2				
PI		NaN	DAR	1.60

Time	R meas	R corr	V DC	I DC
30 s	105.200 GΩ	105.200 GΩ	5.00 kV	47.529 nA
60 s	168.100 GΩ	168.100 GΩ	5.00 kV	29.744 nA

Name Pole 3				
PI		NaN	DAR	1.36

Time	R meas	R corr	V DC	I DC
30 s	89.600 GΩ	89.600 GΩ	5.00 kV	55.804 nA
60 s	122.200 GΩ	122.200 GΩ	5.00 kV	40.917 nA

Name Pole 4				
PI		NaN	DAR	1.77

Time	R meas	R corr	V DC	I DC
30 s	115.800 GΩ	115.800 GΩ	5.00 kV	43.178 nA
60 s	204.800 GΩ	204.800 GΩ	5.00 kV	24.414 nA

Name Pole 5				
PI		NaN	DAR	1.55

Time	R meas	R corr	V DC	I DC
30 s	96.300 GΩ	96.300 GΩ	5.00 kV	51.921 nA
60 s	148.800 GΩ	148.800 GΩ	5.00 kV	33.602 nA

Name Pole 6				
PI		NaN	DAR	1.36

Time	R meas	R corr	V DC	I DC
30 s	99.400 GΩ	99.400 GΩ	5.00 kV	50.302 nA
60 s	134.700 GΩ	134.700 GΩ	5.00 kV	37.120 nA

Name A - Phase Closed				
PI		NaN	DAR	1.38

Time	R meas	R corr	V DC	I DC
30 s	63.400 GΩ	63.400 GΩ	5.00 kV	78.864 nA
60 s	87.600 GΩ	87.600 GΩ	5.00 kV	57.078 nA

Name B - Phase Closed				
PI		NaN	DAR	1.29

Time	R meas	R corr	V DC	I DC
30 s	74.500 GΩ	74.500 GΩ	5.00 kV	67.114 nA
60 s	96.300 GΩ	96.300 GΩ	5.00 kV	51.921 nA

Name C - Phase Closed				
PI	NaN		DAR	1.31 

Time	R meas	R corr	V DC	I DC
30 s	68.300 GΩ	68.300 GΩ	5.00 kV	73.206 nA
60 s	89.200 GΩ	89.200 GΩ	5.00 kV	56.054 nA

52 - T1 - SF-6 Breaker



Client		OCFL2310066 - 52 - T1	
Execution date	10/5/2023	Reason of the job	Routine
Tested by	Matthew Falchetti	Location	Orange Cogen
Approved by		Asset	Circuit breaker
Report ID	2	Asset type	Dead tank SF6 breaker
Report issue date	10/13/2023 8:48:28 AM	Asset serial number	48326-2
Work order		Manufacturer	Siemens

Summary
DLRO Readings - Closed Breaker A - phase - 100 micro B - phase - 104 micro C - phase - 99 micro

Performed tests	Assessment
C Timing	Pass
O Timing	Pass
CO Timing	Pass
OC Timing	Pass
O-CO Timing	Pass
Insulation Resistance	Pass

Overall Assessment	No Faults
--------------------	-----------

Tested by:
Andrew Kirk

Approved by:
Matthew Falchetti

Location & company information			
Location		Company	
Name	Orange Cogen	Company	HVA – P&C / Field Services
Region		Department	South
Division	South	Address	
Area		City	Lakeland
Plant	Orange Cogen	State/Province	Florida
Address	1901 S. Clear Springs Rd	Postal code	33811
City	Bartow	Country	United States
State/Province	Florida	Phone No.	
Postal code	33830	Fax No.	
Country	United States	E-mail	

Geo coordinates	
-----------------	--

Contact person	
Name	
Phone No. 1	
Phone No. 2	
Fax No.	
E-mail	

Comment

Dead tank SF6 breaker nameplate data			
Serial number	48326-2	No. of interrupters p. phase	1
Manufacturer	Siemens	Pole operation	Ganged
Manufacturing year	1994	Pre-insertion resistors	No
Manufacturer type	SPS-72.5-40-1	PIR value	Ω
Asset system code		Grading capacitors	Yes
Apparatus ID	52-T1	Capacitor value	pF
Feeder		Interrupting medium	SF6
No. of phases	3	Tank type	Dead tank

Comment

Ratings

Rated frequency	60.00 Hz
Rated voltage L-L	72.5 kV
Rated current	2000.0 A
Rated SC breaking current	40.0 kA
Short-circuit nominal duration	s
Rated insul. level L-G (BIL)	350.0 kV
Rated interrupting time	ms
Interrupting duty cycle	
Rated power at closing	W
Rated power at opening	W
Rated power at motor charge	W

Contact system

Total travel	in
Damping time	ms
Nozzle length	in

Others

Total weight with gas	4370 lbs
Weight of gas	15 lbs
Volume of gas	gals
Rated gas pressure	80.00 psi @ 21 °C

Spring Operating mechanism nameplate data

Serial No.	48326-2
Manufacturer	Siemens
Manufacturer type	SPS-SE
Manufacturing year	1994
Asset system code	52 -T1

Component	Rated voltage	Rated current	Frequency	
Trip coil 1	135.0 V	A	Hz	DC
Close coil 1	135.0 V	A	Hz	DC
Auxiliary circuits	V	A	Hz	DC
Motor	135.0 V	A	Hz	DC

Bushings nameplate data

Pos.	Serial No.	Manufact.	Man. year	Voltage L-ground	Max. system voltage	Rated current	Insul. level LL
1		LAPP		72.5 kV	72.5 kV	2000.0 A	V
2		LAPP		72.5 kV	72.5 kV	2000.0 A	V
3		LAPP		72.5 kV	72.5 kV	2000.0 A	V
4		LAPP		72.5 kV	72.5 kV	2000.0 A	V
5		LAPP		72.5 kV	72.5 kV	2000.0 A	V
6		LAPP		72.5 kV	72.5 kV	2000.0 A	V

Pos.	Cap. (C1)	PF (C1)	Cap. (C2)	PF (C2)	Insulation type	Tap type
1	pF	%	pF	%	Porcelain dry type	Without tap

Pos.	Cap. (C1)	PF (C1)	Cap. (C2)	PF (C2)	Insulation type	Tap type
2	pF	%	pF	%	Porcelain dry type	Without tap
3	pF	%	pF	%	Porcelain dry type	Without tap
4	pF	%	pF	%	Porcelain dry type	Without tap
5	pF	%	pF	%	Porcelain dry type	Without tap
6	pF	%	pF	%	Porcelain dry type	Without tap

Test set information

Model	Serial number	Calibration date
CIBANO 500	BM271E	2023-07-06
CB TN3	AL015E	2023-07-05

Global test conditions

Weather	Clear	Humidity	94 %
Unit location	Outside	Ambient temperature	23 °C

Operations counter

Counter reading found	32
Counter reading left	

C Timing

Execution date/Time	10/5/2023 9:25:17 AM	
Sequence	C	
Coil supply voltage	135.0 V DC	
Time calculation	According to IEC 62271-100	
Sample rate	10 kHz	

Transducer settings

CB TN3, Channel 1	5.0 V - 0.0125 ° (digital)
-------------------	----------------------------

Main, resistive and auxiliary contacts

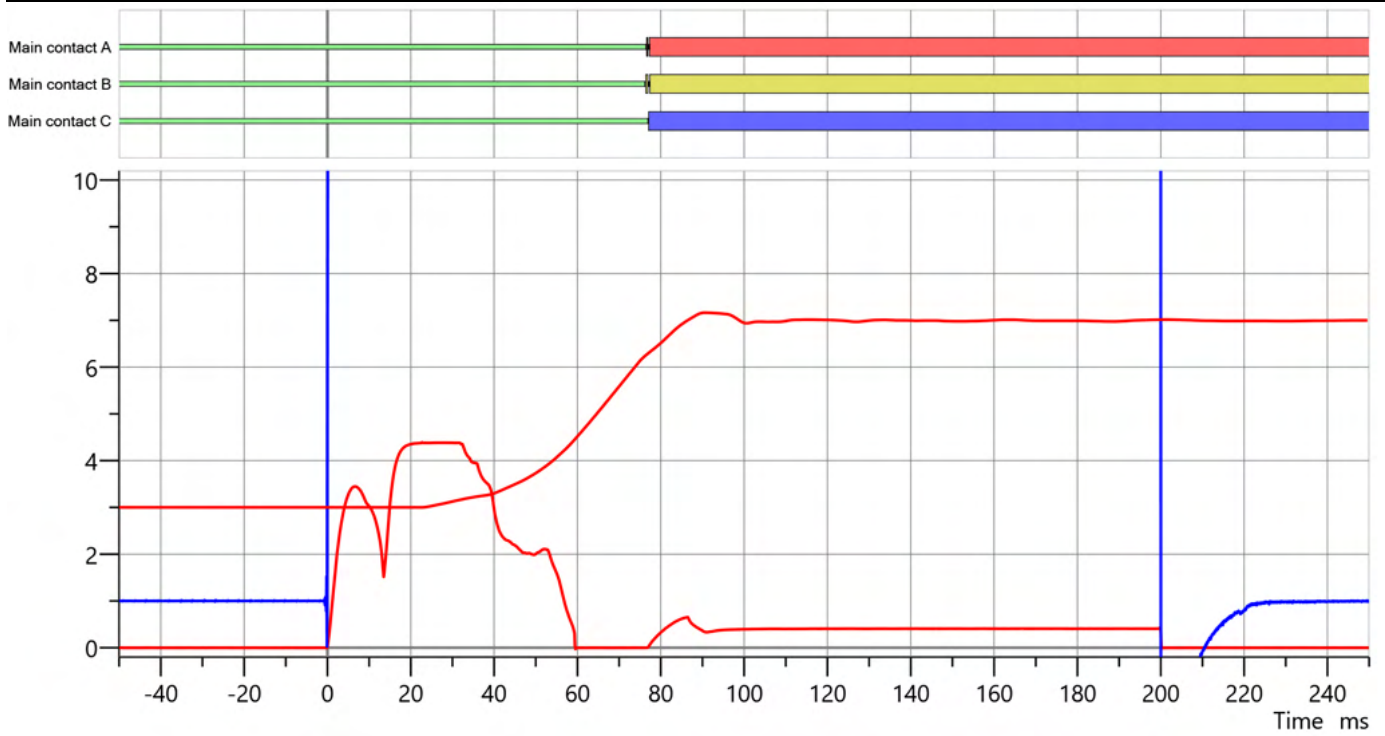

Label	Unit/div.	Y-Axis pos.	Label	Unit/div.	Y-Axis pos.		
Close coil (A)	■	1.00 A	0.00	Channel 1 (travel)	■	7.97 °	3.00
Close coil (V)	■	10.00 V	1.00				

Operating times

Meas.	Closing time (ms)	Closing sync. (ms)	Assessment
Breaker	77.00	0.70	Pass
A	76.50		Pass
Main contact A	76.50		Pass
B	76.30		Pass
Main contact B	76.30		Pass
C	77.00		Pass
Main contact C	77.00		Pass

Assessment Limits	t min	t max
Closing time	70.00 ms	90.00 ms
Closing sync. (contacts within a phase)	ms	ms
Closing sync. (between breaker phases)	ms	ms

Contact travel characteristics

Module	Channel	Total travel	Over-travel	Rebound	Damping dist. BLG	Damping time BLG	Assessment
CB TN3	Channel 1	31.89 °	1.30 °	0.49 °	°	ms	N. rated

Assessment Limits	d min	d max
Total travel, TT	in	in
Over-travel (Close), OT	in	in
Rebound (Close), RB	in	in
Contact wipe (Close), CW	in	in

Assessment Limits	Minimum	Maximum
Damping distance (Close)	in	in
Damping time (Close)	ms	ms

Main contact characteristics

Main contact	Travel data	Contact wipe	Reaction time	PIR close time	Bounce time	Bounce count	Assessment
Main contact A	Channel 1	5.90 °	25.60 ms	ms	0.70 ms	1	N. rated
Main contact B	No data		ms	ms	1.00 ms	1	N. rated
Main contact C	No data		ms	ms	0.00 ms	0	N. rated

Assessment Limits	Minimum	Maximum
Bounce time	ms	ms
Bounce count		
Reaction time	ms	ms

Coil characteristics

	Peak current (A)	Average current (A)	Average voltage (V)	Resistance (Ω)	Assessment
Close	4.39	3.24	132.08	40.72	N. rated

Assessment Limits	Minimum	Maximum
Peak close coil current	A	A
Peak trip coil current	A	A
Average close coil current	A	A
Average trip coil current	A	A
Average close coil voltage	V	V
Average trip coil voltage	V	V
Close coil resistance	Ω	Ω
Trip coil resistance	Ω	Ω

O Timing

Execution date/Time	10/5/2023 9:26:10 AM	
Sequence	O	
Coil supply voltage	135.0 V DC	
Time calculation	According to IEC 62271-100	
Sample rate	10 kHz	

Transducer settings

CB TN3, Channel 1	5.0 V - 0.0125 ° (digital)
-------------------	----------------------------

Main, resistive and auxiliary contacts

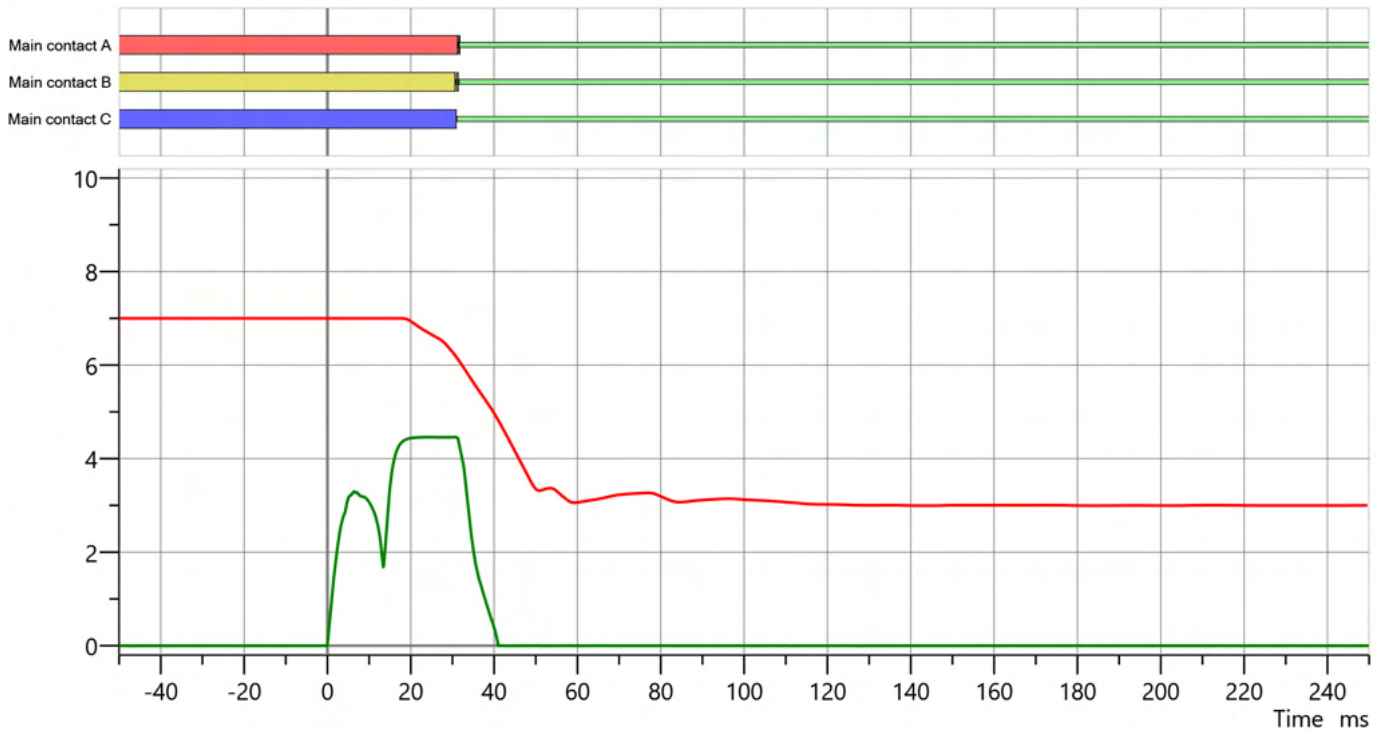

Label	Unit/div.	Y-Axis pos.	Label	Unit/div.	Y-Axis pos.
Trip coil (A)	1.00 A	0.00	Channel 1 (travel)	7.96 °	2.99

Operating times

Meas.	Opening time (ms)	Opening sync. (ms)	Assessment
Breaker	31.50	0.50	Pass
A	31.50		Pass
Main contact A	31.50		Pass
B	31.50		Pass
Main contact B	31.50		Pass
C	31.00		Pass
Main contact C	31.00		Pass

Assessment Limits	t min	t max
Opening time	ms	32.00 ms
Opening sync. (contacts within a phase)	ms	ms
Opening sync. (between breaker phases)	ms	ms

Contact travel characteristics

Module	Channel	Total travel	Over-travel	Rebound	Damping distance	Assessment
CB TN3	Channel 1	31.85 °	0.05 °	0.04 °	°	N. rated

Assessment Limits	d min	d max
Total travel, TT	in	in
Over-travel (Trip), OT	in	in
Rebound (Trip), RB	in	in
Contact wipe (Trip), CW	in	in

Assessment Limits	Minimum	Maximum
Damping distance (Trip)	in	in

Main contact characteristics

Main contact	Travel data	Contact wipe	Reaction time	PIR close time	Bounce time	Bounce count	Assessment
Main contact A	Channel 1	7.15 °	19.60 ms	ms	0.20 ms	1	N. rated
Main contact B	No data		ms	ms	0.80 ms	1	N. rated
Main contact C	No data		ms	ms	0.00 ms	0	N. rated

Assessment Limits	Minimum	Maximum
Bounce time	ms	ms
Bounce count		
Reaction time	ms	ms

Coil characteristics

	Peak current (A)	Average current (A)	Average voltage (V)	Resistance (Ω)	Assessment
Trip A	4.46	3.50	131.98	37.73	N. rated

Assessment Limits	Minimum	Maximum
Peak close coil current	A	A
Peak trip coil current	A	A
Average close coil current	A	A
Average trip coil current	A	A
Average close coil voltage	V	V
Average trip coil voltage	V	V
Close coil resistance	Ω	Ω
Trip coil resistance	Ω	Ω

CO Timing

Execution date/Time	10/5/2023 9:26:36 AM	
Sequence	CO	
Coil supply voltage	135.0 V DC	
Sample rate	10 kHz	

Transducer settings

CB TN3, Channel 1	5.0 V - 0.0125 ° (digital)
CB TN3, Channel 2	5.0 V - 0.0125 ° (digital)
CB TN3, Channel 3	5.0 V - 0.0125 ° (digital)

Main, resistive and auxiliary contacts

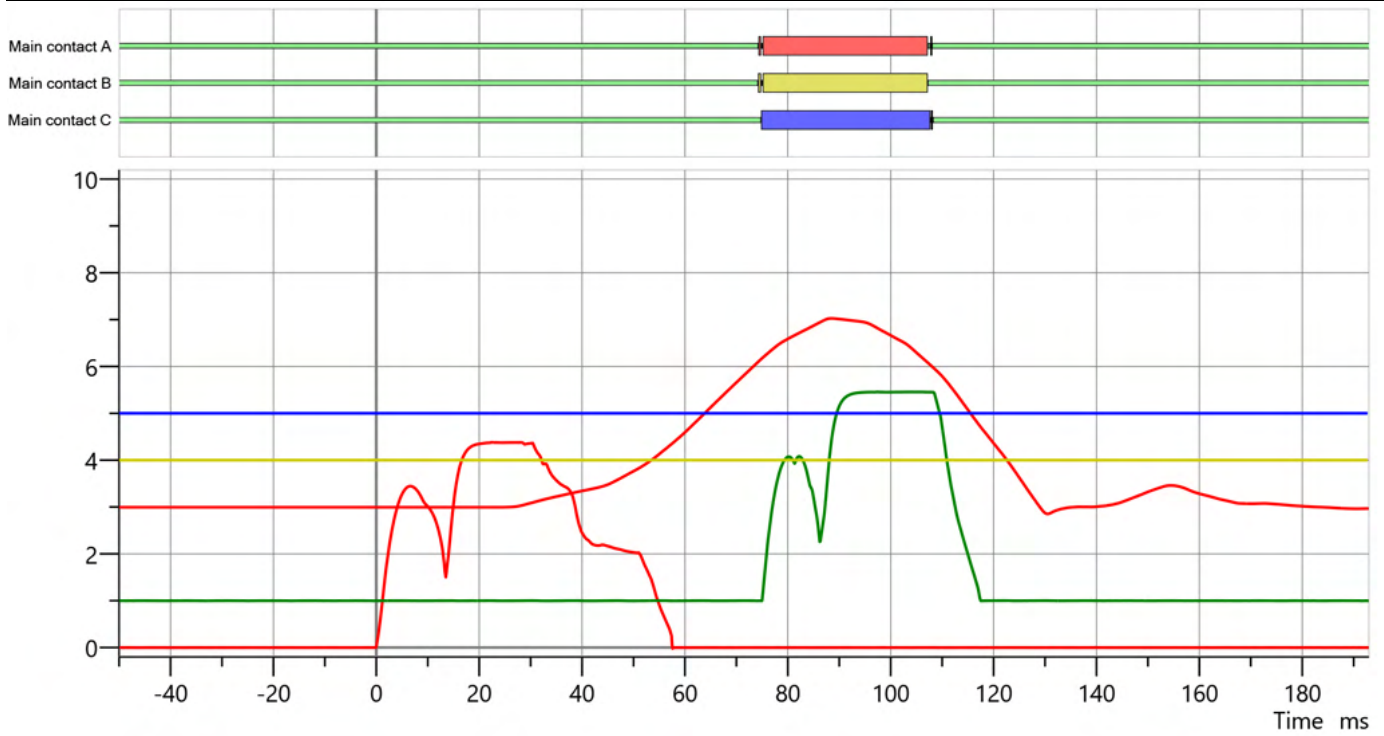

Label	Unit/div.	Y-Axis pos.	Label	Unit/div.	Y-Axis pos.
Close coil (A)	1.00 A	0.00	Channel 2 (travel)	1.00 °	4.00
Trip coil (A)	1.00 A	1.00	Channel 3 (travel)	1.00 °	5.00
Channel 1 (travel)	8.33 °	2.85			

Operating times

Meas.	Closing time (ms)	Closing sync. (ms)	Close-Open time 1 (ms)	Assessment
Breaker	74.80	0.60	34.00	Pass
A	74.30		33.70	Pass
Main contact A	74.30		33.70	Pass
B	74.20		33.00	Pass
Main contact B	74.20		33.00	Pass
C	74.80		33.40	Pass
Main contact C	74.80		33.40	Pass

Assessment Limits	t min	t max
Closing time	70.00 ms	90.00 ms
Closing sync. (contacts within a phase)	ms	ms
Closing sync. (between breaker phases)	ms	ms
Close-Open time	ms	ms

Coil characteristics

	Peak current (A)	Average current (A)	Average voltage (V)	Resistance (Ω)	Assessment
Close	4.38				N. rated
Trip A	4.46				N. rated

Assessment Limits	Minimum	Maximum
Peak close coil current	A	A
Peak trip coil current	A	A

Comments

OC Timing

Execution date/Time	10/5/2023 9:27:27 AM	
Sequence	OC	
Coil supply voltage	135.0 V DC	
Sample rate	10 kHz	

Transducer settings

CB TN3, Channel 1	5.0 V - 0.0125 ° (digital)
CB TN3, Channel 2	5.0 V - 0.0125 ° (digital)
CB TN3, Channel 3	5.0 V - 0.0125 ° (digital)

Main, resistive and auxiliary contacts

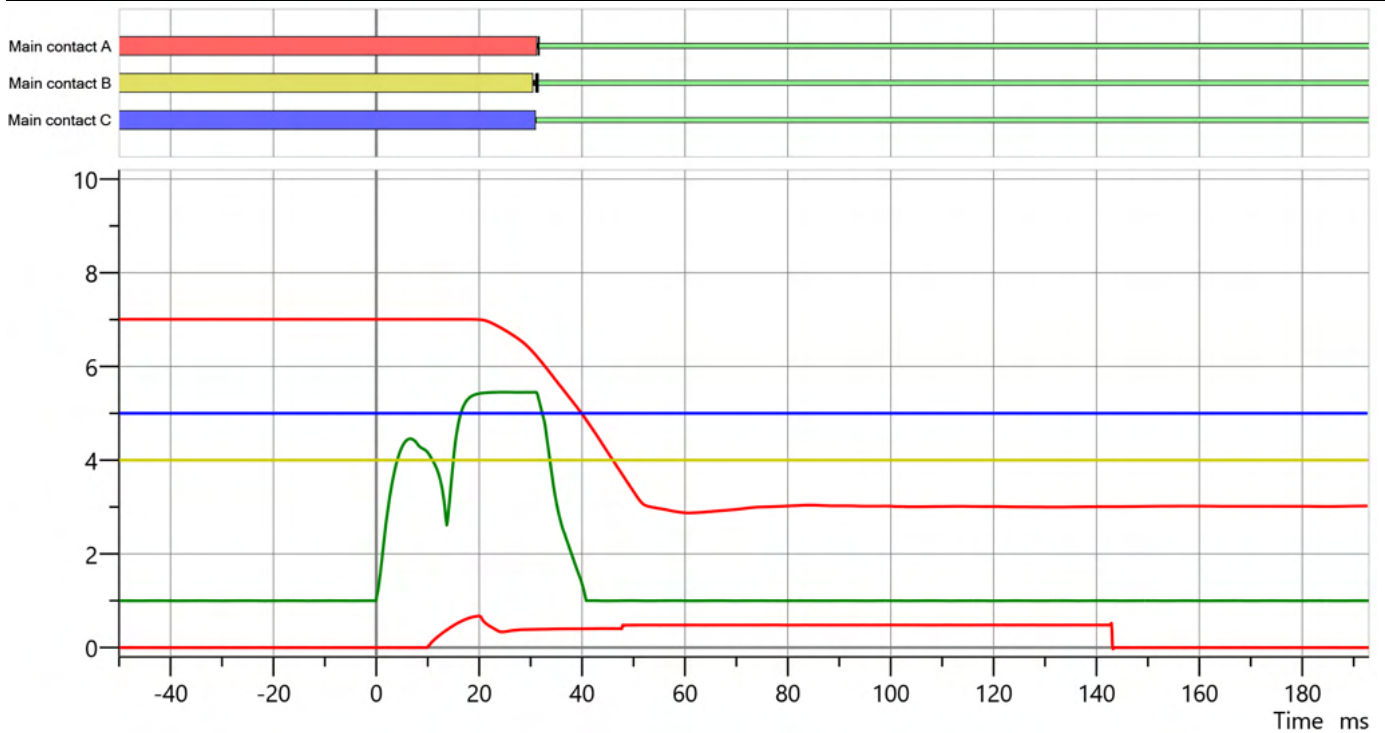

Label	Unit/div.	Y-Axis pos.	Label	Unit/div.	Y-Axis pos.
Close coil (A)	■ 1.00 A	0.00	Channel 2 (travel)	■ 1.00 °	4.00
Trip coil (A)	■ 1.00 A	1.00	Channel 3 (travel)	■ 1.00 °	5.00
Channel 1 (travel)	■ 7.76 °	2.87			

Operating times

Meas.	Opening time (ms)	Opening sync. (ms)	Reclosing time (ms)	Assessment
Breaker	31.50	0.50		Pass
A	31.50			Pass
Main contact A	31.50			Pass
B	31.40			Pass
Main contact B	31.40			Pass
C	31.00			Pass
Main contact C	31.00			Pass

Assessment Limits	t min	t max
Opening time	ms	32.00 ms
Opening sync. (contacts within a phase)	ms	ms
Opening sync. (between breaker phases)	ms	ms
Reclosing time	ms	200.00 ms

Coil characteristics

	Peak current (A)	Average current (A)	Average voltage (V)	Resistance (Ω)	Assessment
Close	0.67				N. rated
Trip A	4.45				N. rated

Assessment Limits	Minimum	Maximum
Peak close coil current	A	A
Peak trip coil current	A	A

Comments

O-CO Timing

Execution date/Time	10/5/2023 9:28:31 AM	
Sequence	O-CO	
Coil supply voltage	135.0 V DC	
Sample rate	10 kHz	

Transducer settings

CB TN3, Channel 1	5.0 V - 0.0125 ° (digital)
CB TN3, Channel 2	5.0 V - 0.0125 ° (digital)
CB TN3, Channel 3	5.0 V - 0.0125 ° (digital)

Main, resistive and auxiliary contacts

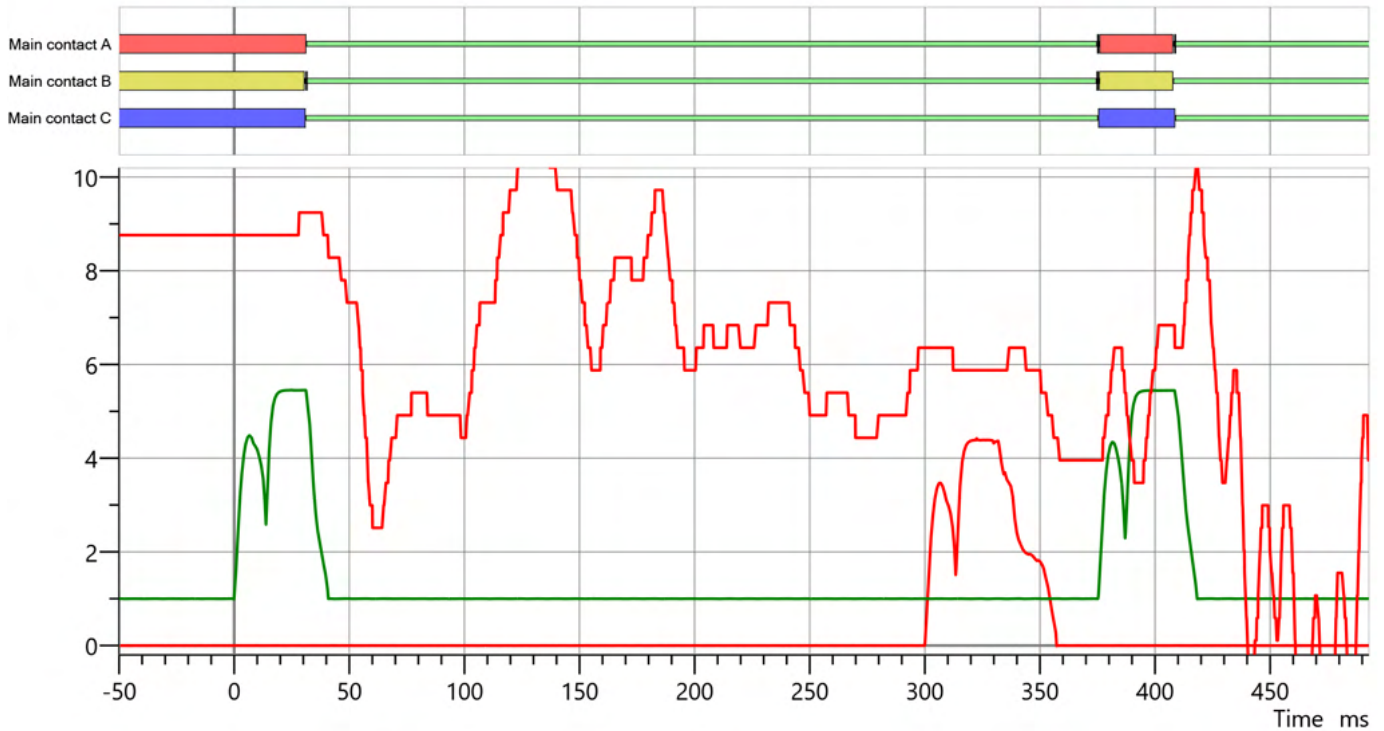

Label	Unit/div.	Y-Axis pos.	Label	Unit/div.	Y-Axis pos.
Close coil (A)	■ 1.00 A	0.00	Channel 2 (travel)	■ 1.00 °	-2.00
Trip coil (A)	■ 1.00 A	1.00	Channel 3 (travel)	■ 1.00 °	-1.00
Channel 1 (travel)	■ 0.03 °	-3.74			

Operating times

Meas.	Opening time (ms)	Opening sync. (ms)	Closing time (ms)	Closing sync. (ms)	Open-Close time (ms)	Close-Open time 1 (ms)	Assessment
Breaker	31.50	0.50	75.30	0.70	343.10	34.20	Pass
A	31.30		74.80		343.50	33.90	Pass
Main contact A	31.30		74.80		343.50	33.90	Pass
B	31.50		74.60		343.10	33.30	Pass
Main contact B	31.50		74.60		343.10	33.30	Pass
C	31.00		75.30		344.30	33.50	Pass
Main contact C	31.00		75.30		344.30	33.50	Pass

Assessment Limits	t min	t max
Opening time	ms	32.00 ms
Opening sync. (contacts within a phase)	ms	ms
Opening sync. (between breaker phases)	ms	ms
Closing time	70.00 ms	90.00 ms
Closing sync. (contacts within a phase)	ms	ms
Closing sync. (between breaker phases)	ms	ms
Open-Close time	ms	ms
Close-Open time	ms	ms

Coil characteristics

	Peak current (A)	Average current (A)	Average voltage (V)	Resistance (Ω)	Assessment
Close	4.42				N. rated
Trip A	4.45				N. rated

Assessment Limits	Minimum	Maximum
Peak close coil current	A	A
Peak trip coil current	A	A

Comments

Insulation Resistance

Comment

Test object temperature	°C
Reference temperature	20 °C

Ambient temperature	23 °C
Humidity	94 %

PI calculation	
Time 1	60 s
Time 2	600 s

DAR calculation	
Time 1	30 s
Time 2	60 s

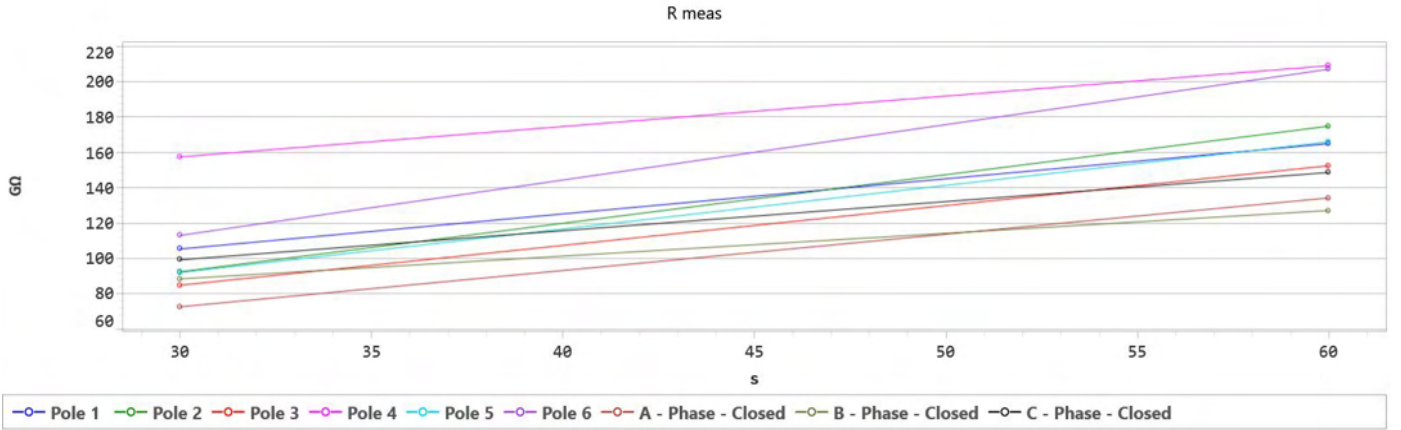

Name Pole 1				
PI		NaN	DAR	1.57

Time	R meas	R corr	V DC	I DC
30 s	105.300 GΩ	105.300 GΩ	5.00 kV	47.483 nA
60 s	164.900 GΩ	164.900 GΩ	5.00 kV	30.321 nA

Name Pole 2				
PI		NaN	DAR	1.89

Time	R meas	R corr	V DC	I DC
30 s	92.400 GΩ	92.400 GΩ	5.00 kV	54.113 nA
60 s	174.800 GΩ	174.800 GΩ	5.00 kV	28.604 nA

Name Pole 3				
PI		NaN	DAR	1.80

Time	R meas	R corr	V DC	I DC
30 s	84.800 GΩ	84.800 GΩ	5.00 kV	58.962 nA
60 s	152.400 GΩ	152.400 GΩ	5.00 kV	32.808 nA

Name Pole 4				
PI		NaN	DAR	1.33

Time	R meas	R corr	V DC	I DC
30 s	157.400 GΩ	157.400 GΩ	5.00 kV	31.766 nA
60 s	209.000 GΩ	209.000 GΩ	5.00 kV	23.923 nA

Name Pole 5				
PI		NaN	DAR	1.80

Time	R meas	R corr	V DC	I DC
30 s	92.000 GΩ	92.000 GΩ	5.00 kV	54.348 nA
60 s	165.900 GΩ	165.900 GΩ	5.00 kV	30.139 nA

Name Pole 6				
PI		NaN	DAR	1.83

Time	R meas	R corr	V DC	I DC
30 s	113.000 GΩ	113.000 GΩ	5.00 kV	44.248 nA
60 s	207.000 GΩ	207.000 GΩ	5.00 kV	24.155 nA

Name A - Phase - Closed				
PI		NaN	DAR	1.85

Time	R meas	R corr	V DC	I DC
30 s	72.600 GΩ	72.600 GΩ	5.00 kV	68.871 nA
60 s	134.200 GΩ	134.200 GΩ	5.00 kV	37.258 nA

Name B - Phase - Closed				
PI		NaN	DAR	1.44

Time	R meas	R corr	V DC	I DC
30 s	88.400 GΩ	88.400 GΩ	5.00 kV	56.561 nA
60 s	127.100 GΩ	127.100 GΩ	5.00 kV	39.339 nA

Name C - Phase - Closed				
PI	NaN		DAR	1.50 

Time	R meas	R corr	V DC	I DC
30 s	99.200 GΩ	99.200 GΩ	5.00 kV	50.403 nA
60 s	148.600 GΩ	148.600 GΩ	5.00 kV	33.647 nA



Orange Cogen
Test Report
2023 Outage Reports
Job #OCFL2310066



Empowering Electrical Infrastructure
for a Sustainable Future



Testing and Commissioning Services

6625 Network Way, Indianapolis, IN 46278

www.hva-inc.com/pc-field-services/

Orange Cogen
1901 S. Clear Springs Rd
Bartow, FL 33830

David Courson,

We are pleased to present the field test reports for 2023 Maintenance Outage conducted by High Voltage Advanced. This report highlights the comprehensive analysis and results obtained during the field-testing phase, providing valuable insights into the performance and reliability of your electrical system under evaluation.

At HVA, we strive to deliver exceptional products and services, backed by rigorous testing and analysis. We understand the significance of the field test results in evaluating the effectiveness and safety of your electrical system. The information contained in this report is intended to provide you with a detailed overview of the performance characteristics, environmental considerations, and any observed issues during the testing phase.

Key Sections of the Field Test Report:

- **Equipment Tested:** all equipment that was tested during the field-testing phase.
- **Scope of Work:** Detailed explanation of the goals and objectives of the field test.
- **Observations and Recommendations:** Identification of any observed issues or challenges, accompanied by recommendations for improvement or further investigations, if necessary.
- **Results:** In-depth examination of the obtained data, including test data sheets, system behavior, and any deviations from expected outcomes at the time of testing.

We understand that your valuable feedback is crucial in our continuous efforts to enhance our offerings. Therefore, we encourage you to review the field test report thoroughly and reach out to us with any questions or concerns you may have. Our dedicated team of experts is available to provide further clarification or address any questions you may have.

We sincerely appreciate the opportunity to collaborate with you on this project and remain committed to delivering the highest quality solutions to meet your needs. Should you require any additional information or assistance, please do not hesitate to contact us.

Thank you for your trust and continued partnership.

Sincerely,

Matthew Falchetti

Lead Technician

NICET I #153748

Cell: (863)528-4124

HVA - P&C / Field Services

matt.falchetti@hva-inc.com

www.hva-inc.com/pc-field-services/



Chris Roehm

Field Services Manager

NICET III #152740

Cell: (843)818-8847

HVA - P&C / Field Services

chris.roehm@hva-inc.com

www.hva-inc.com/pc-field-services/





Testing and Commissioning Services

6625 Network Way, Indianapolis, IN 46278

www.hva-inc.com/pc-field-services/

Equipment Tested: T1 & T2 Maintenance Scope of Work: Transformers, Breakers, and

Contactors

Observations and Recommendations:

52GT1 Brekaer: Damaged breaker parts sourced from spare. New parts are being sourced to replace.

52-1 Breaker: Found grounded charging motor. New parts are being sourced to replace.

Results: We were able to temporarily clear ground on charging motor on 52-1 and in-service

52GT1 breaker has been repaired.

2023 Outage Reports



Bolt was not in place for breaker to be racked out and closing latch to be in the up position



Wheels should be attached here, but broke off



All 4 wheels broken on breaker

Deficiency Summary
Job #OCFL2310066



PAGE _____

Customer Orange Cogen
Owner Orange Cogen

Site: Orange Cogen Page: _____
Substation: Switch-Yard Date: 10/6/2023
Equipment: 15kV Breakers
Equipment: 52GT1 Breaker

DEFICIENCIES: Wheels on breaker all broke - Replaced with ones from Spare Breaker

Site: Orange Cogen Page: _____
Substation: Switch-Yard Date: 9/28/2023
Equipment: 15kV Breakers
Equipment: 52STG Breaker

DEFICIENCIES: Open / Close interlock bolt was missing and held the lever down - Fixed

MEDIUM VOLTAGE VACUUM MOTOR STARTER TEST



CUSTOMER Orange Cogen PAGE _____
 ADDRESS 1901 S. Clear Springs Rd; Bartow FL 33830 DATE 10/2/2023
 OWNER Orange Cogen; 1901 S. Clear Springs Rd; Bartow FL 33830 JOB # OCFL2310066
 SITE Orange Cogen TEST STATUS _____ Pass
 SUBSTATION Main MCC ASSET ID 250 HP/020D130 Gas BSTR Compressor - 3
 EQUIPMENT 4160 Starters AMBIENT TEMPERATURE 70 °F HUMIDITY 61 %

NAMEPLATE DATA

MANUFACTURER Siemens SERIAL NO. RAL-71921-2FB-072994 TYPE AC Contactor -FM
 CATALOG NO. 93H3533034A3A STARTER SIZE 4800 FORM N/A
 SERIES 93H35 AC Contactor MAXIMUM VOLTAGE 5000 INT. RATING kA @ kV
 OPERATING VOLTAGE 4160 CONTROL VOLTAGE 125 Other _____
 MOTOR CONTROL CENTER SYSTEM VOLTAGE _____ STARTER IDENTIFICATION _____

OVERCURRENT PROTECTION DEVICES

CONTROL POWER FUSE: MFR. Gould Shawmut TYPE PT Fuse SIZE 4800 V -2E amps
 MAIN POWER FUSE: MFR. Gould Shawmut - Amp-Trap TYPE Current Limiting Fuse SIZE 2400/4800V - 225 amps
 OVERLOAD PROTECTION: _____ TYPE _____ TESTED YES NO

INSTRUMENT TRANSFORMER DATA

CONTROL POWER TRANSFORMER: MFR. Siemens Energy VA RATING 115 TYPE CPT VOLTAGE 4000
 CURRENT TRANSFORMER: MFR. _____ RATIO :5 TYPE _____ CAT. NO. _____

Description	INSPECTED	CONDITION	CLEAN/LUBE
OVERALL CLEANLINESS	<input checked="" type="checkbox"/>	Good	
INSULATING MEMBERS	<input checked="" type="checkbox"/>	Good	
MECHANICAL CONNECTIONS	<input checked="" type="checkbox"/>	Good	
STRUCTURAL MEMBERS	<input checked="" type="checkbox"/>	Good	
CUBICLE	<input checked="" type="checkbox"/>	Good	
RACKING DEVICES	<input checked="" type="checkbox"/>	Good	
SHUTTER	<input checked="" type="checkbox"/>	Good	

Description	INSPECTED	CONDITION	CLEAN/LUBE
OPERATING MECHANISM	<input checked="" type="checkbox"/>	Good	
CONTACT FINGERS	<input checked="" type="checkbox"/>	Good	
VACUUM INTERRUPTER	<input checked="" type="checkbox"/>	Good	
CONTACT EROSION INDICATOR	<input checked="" type="checkbox"/>	Good	
CONTACT SEQUENCE	<input checked="" type="checkbox"/>	Good	
GROUND CONNECTIONS	<input checked="" type="checkbox"/>	Good	
AUXILIARY DEVICES	<input checked="" type="checkbox"/>	Good	

TEMPERATURE CORRECTION FACTOR TO: 20°C 40°C
 INSULATION TEST VOLTAGE 5000 KVDC TEST VOLTAGE MULTIPLIER, K1 = _____ K2 = (K1) (TCF)
 EQUIPMENT TEMPERATURE 20 °C TEMPERATURE CORRECTION FACTOR TO 20°C, TCF 1
 MILLIWATT LOSS TEST VOLTAGE _____ KVDC HIGH POTENTIAL TEST VOLTAGE _____ KVDC 12,000 KVAC

INSULATION TESTS	POLE 1	POLE 2	POLE 3
	READING	READING	READING
POLE TO POLE - CLOSED	6.92 T	5.40 T	8.12 T
POLE TO FRAME - CLOSED	3.92 T	8.54 T	3.99 T
LINE TO FRAME - OPEN	7.12 T	6.75 T	4.99 T
LOAD TO FRAME - OPEN	1.33 T	3.46 T	3.87 T
LINE TO LOAD - OPEN	2.01 T	6.01 T	8.51 T

CONTACT MEASUREMENTS

	POLE 1	POLE 2	POLE 3
POLE RESISTANCE	RDG. 105	100	111
MICRO - OHMS			
MAIN FUSE	RDG. 0.5	0.5	0.4
CPT - FUSE	20°C 0.8	0.8	

CONTROL WIRING - MEGOHMS			
READING		20°C	

		POLE 1	POLE 2	POLE 3
HIPOT - OPEN	AC	4.0	4.0	4.0
HIPOT - CLOSED	AC	4.0	4.0	4.2

TESTED BY: Matthew Falchetti / Andrew Kirk

MEDIUM VOLTAGE VACUUM MOTOR STARTER TEST



PAGE _____

COMMENTS:

DEFICIENCIES:

EQUIPMENT USED:

#	Manufacturer	Model	Serial / ID Number	Type	Calibration Date	Calibration Due
1	FLUKE	FLUKE - 87V	38210208	MULTIMETER	1/14/2023	1/14/2024
2	MEGGER	10 kv	102311999	INSULATION	1/10/2023	1/10/2024
3	MEGGER	1006-603	102305978	DLRO10HD	1/14/2023	1/14/2024
4	HVI	50kV AC HIPOT	2534	AC - HIPOT	1/8/2023	1/8/2024

MEDIUM VOLTAGE VACUUM MOTOR STARTER TEST



CUSTOMER Orange Cogen PAGE _____
 ADDRESS 1901 S. Clear Springs Rd; Bartow FL 33830 DATE 10/2/2023
 OWNER Orange Cogen; 1901 S. Clear Springs Rd; Bartow FL 33830 JOB # OCFL2310066
 SITE Orange Cogen TEST STATUS _____ Pass
 SUBSTATION Main MCC ASSET ID 1500 HP/020D420 Electric Chiller-2
 EQUIPMENT 4160 Starters AMBIENT TEMPERATURE 70 °F HUMIDITY 61 %

NAMEPLATE DATA

MANUFACTURER Siemens SERIAL NO. RAL-71921-2RC-072694 TYPE AC Contactor -FM
 CATALOG NO. 93H3533034A3A STARTER SIZE 4800 FORM N/A
 SERIES 93H35 AC Contactor MAXIMUM VOLTAGE 5000 INT. RATING kA @ kV
 OPERATING VOLTAGE 4160 CONTROL VOLTAGE 125 Other _____
 MOTOR CONTROL CENTER SYSTEM VOLTAGE _____ STARTER IDENTIFICATION _____

OVERCURRENT PROTECTION DEVICES

CONTROL POWER FUSE: MFR. Gould Shawmut TYPE PT Fuse SIZE 4800 V -2E amps
 MAIN POWER FUSE: MFR. Gould Shawmut - Amp-Trap TYPE Current Limiting Fuse SIZE 2400/4800V - 225 amps
 OVERLOAD PROTECTION: _____ TYPE _____ TESTED YES NO

INSTRUMENT TRANSFORMER DATA

CONTROL POWER TRANSFORMER: MFR. Siemens Energy VA RATING 115 TYPE CPT VOLTAGE 4000
 CURRENT TRANSFORMER: MFR. _____ RATIO :5 TYPE _____ CAT. NO. _____

Description	INSPECTED	CONDITION	CLEAN/LUBE
OVERALL CLEANLINESS	✓	Good	
INSULATING MEMBERS	✓	Good	
MECHANICAL CONNECTIONS	✓	Good	
STRUCTURAL MEMBERS	✓	Good	
CUBICLE	✓	Good	
RACKING DEVICES	✓	Good	
SHUTTER	✓	Good	

Description	INSPECTED	CONDITION	CLEAN/LUBE
OPERATING MECHANISM	✓	Good	
CONTACT FINGERS	✓	Good	
VACUUM INTERRUPTER	✓	Good	
CONTACT EROSION INDICATOR	✓	Good	
CONTACT SEQUENCE	✓	Good	
GROUND CONNECTIONS	✓	Good	
AUXILIARY DEVICES	✓	Good	

TEMPERATURE CORRECTION FACTOR TO: 20°C 40°C
 INSULATION TEST VOLTAGE 5000 KVDC TEST VOLTAGE MULTIPLIER, K1 = _____ K2 = (K1) (TCF)
 EQUIPMENT TEMPERATURE 20 °C TEMPERATURE CORRECTION FACTOR TO 20°C, TCF 1
 MILLIWATT LOSS TEST VOLTAGE _____ KVDC HIGH POTENTIAL TEST VOLTAGE _____ KVDC 12,000 KVAC

INSULATION TESTS

	POLE 1	POLE 2	POLE 3
	READING	READING	READING
POLE TO POLE - CLOSED	1.42 T	2.06 T	1.94 T
POLE TO FRAME - CLOSED	1.17 T	1.65 T	1.83 T
LINE TO FRAME - OPEN	1.14 T	1.44 T	1.49 T
LOAD TO FRAME - OPEN	1.33 T	1.39 T	1.28 T
LINE TO LOAD - OPEN	1.30 T	1.46 T	1.60 T

CONTACT MEASUREMENTS

	RDG.	POLE 1	POLE 2	POLE 3
POLE RESISTANCE		94	100	130
MICRO - OHMS				
MAIN FUSE	RDG.	1.4	1.9	1.9
CPT - FUSE	20°C	1.4	1.3	

CONTROL WIRING - MEGOHMS			
READING		20°C	

		POLE 1	POLE 2	POLE 3
HIPOT - OPEN	AC	3.8	4.0	4.0
HIPOT - CLOSED	AC	4.0	3.8	4.0

TESTED BY: Matthew Falchetti / Andrew Kirk

MEDIUM VOLTAGE VACUUM MOTOR STARTER TEST



PAGE _____

COMMENTS:

DEFICIENCIES:

EQUIPMENT USED:

#	Manufacturer	Model	Serial / ID Number	Type	Calibration Date	Calibration Due
1	FLUKE	FLUKE - 87V	38210208	MULTIMETER	1/14/2023	1/14/2024
2	MEGGER	10 kv	102311999	INSULATION	1/10/2023	1/10/2024
3	MEGGER	1006-603	102305978	DLRO10HD	1/14/2023	1/14/2024
4	HVI	50kV AC HIPOT	2534	AC - HIPOT	1/8/2023	1/8/2024

MEDIUM VOLTAGE VACUUM MOTOR STARTER TEST



CUSTOMER Orange Cogen PAGE _____
 ADDRESS 1901 S. Clear Springs Rd; Bartow FL 33830 DATE 10/2/2023
 OWNER Orange Cogen; 1901 S. Clear Springs Rd; Bartow FL 33830 JOB # OCFL2310066
 SITE Orange Cogen TEST STATUS _____ Pass
 SUBSTATION Main MCC ASSET ID 250 HP 006D630 Feedwater Pump - 3
 EQUIPMENT 4160 Starters AMBIENT TEMPERATURE 70 °F HUMIDITY 61 %

NAMEPLATE DATA

MANUFACTURER Siemens SERIAL NO. RAL-71921-10FC-072894 TYPE AC Contactor -FM
 CATALOG NO. 93H3533034A3A STARTER SIZE 4800 FORM N/A
 SERIES 93H35 AC Contactor MAXIMUM VOLTAGE 5000 INT. RATING kA @ kV
 OPERATING VOLTAGE 4160 CONTROL VOLTAGE 125 Other _____
 MOTOR CONTROL CENTER SYSTEM VOLTAGE _____ STARTER IDENTIFICATION _____

OVERCURRENT PROTECTION DEVICES

CONTROL POWER FUSE: MFR. Gould Shawmut TYPE PT Fuse SIZE 4800 V -2E amps
 MAIN POWER FUSE: MFR. Gould Shawmut - Amp-Trap TYPE Current Limiting Fuse SIZE 2400/4800V - 225 amps
 OVERLOAD PROTECTION: _____ TYPE _____ TESTED YES NO

INSTRUMENT TRANSFORMER DATA

CONTROL POWER TRANSFORMER: MFR. Siemens Energy VA RATING 115 TYPE CPT VOLTAGE 4000
 CURRENT TRANSFORMER: MFR. _____ RATIO :5 TYPE _____ CAT. NO. _____

Description	INSPECTED	CONDITION	CLEAN/LUBE
OVERALL CLEANLINESS	<input checked="" type="checkbox"/>	Good	
INSULATING MEMBERS	<input checked="" type="checkbox"/>	Good	
MECHANICAL CONNECTIONS	<input checked="" type="checkbox"/>	Good	
STRUCTURAL MEMBERS	<input checked="" type="checkbox"/>	Good	
CUBICLE	<input checked="" type="checkbox"/>	Good	
RACKING DEVICES	<input checked="" type="checkbox"/>	Good	
SHUTTER	<input checked="" type="checkbox"/>	Good	

Description	INSPECTED	CONDITION	CLEAN/LUBE
OPERATING MECHANISM	<input checked="" type="checkbox"/>	Good	
CONTACT FINGERS	<input checked="" type="checkbox"/>	Good	
VACUUM INTERRUPTER	<input checked="" type="checkbox"/>	Good	
CONTACT EROSION INDICATOR	<input checked="" type="checkbox"/>	Good	
CONTACT SEQUENCE	<input checked="" type="checkbox"/>	Good	
GROUND CONNECTIONS	<input checked="" type="checkbox"/>	Good	
AUXILIARY DEVICES	<input checked="" type="checkbox"/>	Good	

TEMPERATURE CORRECTION FACTOR TO: 20°C 40°C
 INSULATION TEST VOLTAGE 5000 KVDC TEST VOLTAGE MULTIPLIER, K1 = _____ K2 = (K1) (TCF)
 EQUIPMENT TEMPERATURE 20 °C TEMPERATURE CORRECTION FACTOR TO 20°C, TCF 1
 MILLIWATT LOSS TEST VOLTAGE _____ KVDC HIGH POTENTIAL TEST VOLTAGE _____ KVDC 12,000 KVAC

INSULATION TESTS	POLE 1	POLE 2	POLE 3
	READING	READING	READING
POLE TO POLE - CLOSED	6.33 T	6.52 T	6.73 T
POLE TO FRAME - CLOSED	4.90 T	3.20 T	7.34 T
LINE TO FRAME - OPEN	8.17 T	6.85 T	7.01 T
LOAD TO FRAME - OPEN	1.95 T	1.78 T	1.59 T
LINE TO LOAD - OPEN	8.99 T	10.38 T	11.9 T

CONTACT MEASUREMENTS

	POLE 1	POLE 2	POLE 3
POLE RESISTANCE	RDG. 99	100	101
MICRO - OHMS			
MAIN FUSE	RDG. 0.9	0.9	1.1
CPT - FUSE	20°C 1.2	1.2	

CONTROL WIRING - MEGOHMS			
READING		20°C	

		POLE 1	POLE 2	POLE 3
HIPOT - OPEN	AC	3.8	4.0	4.0
HIPOT - CLOSED	AC	4.0	4.0	4.0

TESTED BY: Matthew Falchetti / Andrew Kirk

MEDIUM VOLTAGE VACUUM MOTOR STARTER TEST



PAGE _____

COMMENTS:

DEFICIENCIES:

EQUIPMENT USED

#	Manufacturer	Model	Serial / ID Number	Type	Calibration Date	Calibration Due
1	FLUKE	FLUKE - 87V	38210208	MULTIMETER	1/14/2023	1/14/2024
2	MEGGER	10 kv	102311999	INSULATION	1/10/2023	1/10/2024
3	MEGGER	1006-603	102305978	DLRO10HD	1/14/2023	1/14/2024
4	HVI	50kV AC HIPOT	2534	AC - HIPOT	1/8/2023	1/8/2024

MEDIUM VOLTAGE VACUUM MOTOR STARTER TEST



CUSTOMER Orange Cogen PAGE _____
 ADDRESS 1901 S. Clear Springs Rd; Bartow FL 33830 DATE 10/2/2023
 OWNER Orange Cogen; 1901 S. Clear Springs Rd; Bartow FL 33830 JOB # OCFL2310066
 SITE Orange Cogen TEST STATUS _____ Pass
 SUBSTATION Main MCC ASSET ID 1500 HP/020D410 Electric Chiller-1
 EQUIPMENT 4160 Starters AMBIENT TEMPERATURE 70 °F HUMIDITY 61 %

NAMEPLATE DATA

MANUFACTURER Siemens SERIAL NO. RAL-71921-11RB-072994 TYPE AC Contactor -FM
 CATALOG NO. 93H3533034A3A STARTER SIZE 4800 FORM N/A
 SERIES 93H35 AC Contactor MAXIMUM VOLTAGE 5000 INT. RATING kA @ kV
 OPERATING VOLTAGE 4160 CONTROL VOLTAGE 125 Other _____
 MOTOR CONTROL CENTER SYSTEM VOLTAGE _____ STARTER IDENTIFICATION _____

OVERCURRENT PROTECTION DEVICES

CONTROL POWER FUSE: MFR. Gould Shawmut TYPE PT Fuse SIZE 4800 V -2E amps
 MAIN POWER FUSE: MFR. Gould Shawmut - Amp-Trap TYPE Current Limiting Fuse SIZE 2400/4800V - 225 amps
 OVERLOAD PROTECTION: _____ TYPE _____ TESTED YES NO

INSTRUMENT TRANSFORMER DATA

CONTROL POWER TRANSFORMER: MFR. Siemens Energy VA RATING 115 TYPE CPT VOLTAGE 4000
 CURRENT TRANSFORMER: MFR. _____ RATIO :5 TYPE _____ CAT. NO. _____

Description	INSPECTED	CONDITION	CLEAN/LUBE
OVERALL CLEANLINESS	✓	Good	
INSULATING MEMBERS	✓	Good	
MECHANICAL CONNECTIONS	✓	Good	
STRUCTURAL MEMBERS	✓	Good	
CUBICLE	✓	Good	
RACKING DEVICES	✓	Good	
SHUTTER	✓	Good	

Description	INSPECTED	CONDITION	CLEAN/LUBE
OPERATING MECHANISM	✓	Good	
CONTACT FINGERS	✓	Good	
VACUUM INTERRUPTER	✓	Good	
CONTACT EROSION INDICATOR	✓	Good	
CONTACT SEQUENCE	✓	Good	
GROUND CONNECTIONS	✓	Good	
AUXILIARY DEVICES	✓	Good	

TEMPERATURE CORRECTION FACTOR TO: 20°C 40°C
 INSULATION TEST VOLTAGE 5000 KVDC TEST VOLTAGE MULTIPLIER, K1 = _____ K2 = (K1) (TCF)
 EQUIPMENT TEMPERATURE 20 °C TEMPERATURE CORRECTION FACTOR TO 20°C, TCF 1
 MILLIWATT LOSS TEST VOLTAGE _____ KVDC HIGH POTENTIAL TEST VOLTAGE _____ KVDC 12,000 KVAC

INSULATION TESTS	POLE 1	POLE 2	POLE 3
	READING	READING	READING
POLE TO POLE - CLOSED	2.01 T	1.08 T	1.17 T
POLE TO FRAME - CLOSED	1.08 T	805 G	925 G
LINE TO FRAME - OPEN	1.05 T	1.26 T	856 G
LOAD TO FRAME - OPEN	2.15 T	1.04 T	1.17 T
LINE TO LOAD - OPEN	786 G	1.21 T	1.37 T

CONTACT MEASUREMENTS

	POLE 1	POLE 2	POLE 3
POLE RESISTANCE	RDG. 88	105	97
MICRO - OHMS			
MAIN FUSE	RDG. 0.8	0.7	0.7
CPT - FUSE	20°C 1.2	1.6	

CONTROL WIRING - MEGOHMS			
READING		20°C	

		POLE 1	POLE 2	POLE 3
HIPOT - OPEN	AC	4.0	3.8	4.2
HIPOT - CLOSED	AC	4.2	4.0	4.2

TESTED BY: Matthew Falchetti / Andrew Kirk

MEDIUM VOLTAGE VACUUM MOTOR STARTER TEST



PAGE _____

COMMENTS:

DEFICIENCIES:

EQUIPMENT USED

#	Manufacturer	Model	Serial / ID Number	Type	Calibration Date	Calibration Due
1	FLUKE	FLUKE - 87V	38210208	MULTIMETER	1/14/2023	1/14/2024
2	MEGGER	10 kv	102311999	INSULATION	1/10/2023	1/10/2024
3	MEGGER	1006-603	102305978	DLRO10HD	1/14/2023	1/14/2024
4	HVI	50kV AC HIPOT	2534	AC - HIPOT	1/8/2023	1/8/2024

MEDIUM VOLTAGE VACUUM MOTOR STARTER TEST



CUSTOMER Orange Cogen PAGE _____
 ADDRESS 1901 S. Clear Springs Rd; Bartow FL 33830 DATE 10/2/2023
 OWNER Orange Cogen; 1901 S. Clear Springs Rd; Bartow FL 33830 JOB # OCFL2310066
 SITE Orange Cogen TEST STATUS _____ Pass _____
 SUBSTATION Main MCC ASSET ID 1500 HP/020D430 Electric Chiller-3
 EQUIPMENT 4160 Starters AMBIENT TEMPERATURE 70 °F HUMIDITY 61 %

NAMEPLATE DATA

MANUFACTURER Siemens SERIAL NO. RAL-71921-11RC-072894 TYPE AC Contactor -FM
 CATALOG NO. 93H3533034A3A STARTER SIZE 4800 FORM N/A
 SERIES 93H35 AC Contactor MAXIMUM VOLTAGE 5000 INT. RATING kA @ kV
 OPERATING VOLTAGE 4160 CONTROL VOLTAGE 125 Other _____
 MOTOR CONTROL CENTER SYSTEM VOLTAGE _____ STARTER IDENTIFICATION _____

OVERCURRENT PROTECTION DEVICES

CONTROL POWER FUSE: MFR. Gould Shawmut TYPE PT Fuse SIZE 4800 V -2E amps
 MAIN POWER FUSE: MFR. Gould Shawmut - Amp-Trap TYPE Current Limiting Fuse SIZE 2400/4800V - 225 amps
 OVERLOAD PROTECTION: _____ TYPE _____ TESTED YES NO

INSTRUMENT TRANSFORMER DATA

CONTROL POWER TRANSFORMER: MFR. Siemens Energy VA RATING 115 TYPE CPT VOLTAGE 4000
 CURRENT TRANSFORMER: MFR. _____ RATIO :5 TYPE _____ CAT. NO. _____

Description	INSPECTED	CONDITION	CLEAN/LUBE
OVERALL CLEANLINESS	<input checked="" type="checkbox"/>	Good	
INSULATING MEMBERS	<input checked="" type="checkbox"/>	Good	
MECHANICAL CONNECTIONS	<input checked="" type="checkbox"/>	Good	
STRUCTURAL MEMBERS	<input checked="" type="checkbox"/>	Good	
CUBICLE	<input checked="" type="checkbox"/>	Good	
RACKING DEVICES	<input checked="" type="checkbox"/>	Good	
SHUTTER	<input checked="" type="checkbox"/>	Good	

Description	INSPECTED	CONDITION	CLEAN/LUBE
OPERATING MECHANISM	<input checked="" type="checkbox"/>	Good	
CONTACT FINGERS	<input checked="" type="checkbox"/>	Good	
VACUUM INTERRUPTER	<input checked="" type="checkbox"/>	Good	
CONTACT EROSION INDICATOR	<input checked="" type="checkbox"/>	Good	
CONTACT SEQUENCE	<input checked="" type="checkbox"/>	Good	
GROUND CONNECTIONS	<input checked="" type="checkbox"/>	Good	
AUXILIARY DEVICES	<input checked="" type="checkbox"/>	Good	

TEMPERATURE CORRECTION FACTOR TO: 20°C 40°C
 INSULATION TEST VOLTAGE 5000 KVDC TEST VOLTAGE MULTIPLIER, K1 = _____ K2 = (K1) (TCF)
 EQUIPMENT TEMPERATURE 20 °C TEMPERATURE CORRECTION FACTOR TO 20°C, TCF 1
 MILLIWATT LOSS TEST VOLTAGE _____ KVDC HIGH POTENTIAL TEST VOLTAGE _____ KVDC 12,000 KVAC

INSULATION TESTS	POLE 1	POLE 2	POLE 3
	READING	READING	READING
POLE TO POLE - CLOSED	2.84 T	1.36 T	2.43 T
POLE TO FRAME - CLOSED	1.21 T	1.26 T	1.45 T
LINE TO FRAME - OPEN	2.20 T	1.80 T	1.18 T
LOAD TO FRAME - OPEN	2.02 T	2.08 T	1.14 T
LINE TO LOAD - OPEN	2.21 T	825 G	1.60 T

CONTACT MEASUREMENTS

	POLE 1	POLE 2	POLE 3
POLE RESISTANCE	RDG. 91	112	96
MICRO - OHMS			
MAIN FUSE	RDG. 0.4	0.3	0.3
CPT - FUSE	20°C 0.7	0.7	

CONTROL WIRING - MEGOHMS			
READING		20°C	

		POLE 1	POLE 2	POLE 3
HIPOT - OPEN	AC	4.0	4.0	4.0
HIPOT - CLOSED	AC	4.0	4.0	4.0

TESTED BY: Matthew Falchetti / Andrew Kirk

MEDIUM VOLTAGE VACUUM MOTOR STARTER TEST



PAGE _____

COMMENTS:

DEFICIENCIES:

EQUIPMENT USED

#	Manufacturer	Model	Serial / ID Number	Type	Calibration Date	Calibration Due
1	FLUKE	FLUKE - 87V	38210208	MULTIMETER	1/14/2023	1/14/2024
2	MEGGER	10 kv	102311999	INSULATION	1/10/2023	1/10/2024
3	MEGGER	1006-603	102305978	DLRO10HD	1/14/2023	1/14/2024
4	HVI	50kV AC HIPOT	2534	AC - HIPOT	1/8/2023	1/8/2024

MEDIUM VOLTAGE VACUUM MOTOR STARTER TEST



CUSTOMER Orange Cogen PAGE _____
 ADDRESS 1901 S. Clear Springs Rd; Bartow FL 33830 DATE 10/2/2023
 OWNER Orange Cogen; 1901 S. Clear Springs Rd; Bartow FL 33830 JOB # OCFL2310066
 SITE Orange Cogen TEST STATUS _____ Pass
 SUBSTATION Main MCC ASSET ID 250 HP/020D120 Gas BSTR Compressor - 2
 EQUIPMENT 4160 Starters AMBIENT TEMPERATURE 70 °F HUMIDITY 61 %

NAMEPLATE DATA

MANUFACTURER Siemens SERIAL NO. RAL-71921-11FC-072894 TYPE AC Contactor -FM
 CATALOG NO. 93H3533034A3A STARTER SIZE 4800 FORM N/A
 SERIES 93H35 AC Contactor MAXIMUM VOLTAGE 5000 INT. RATING kA @ kV
 OPERATING VOLTAGE 4160 CONTROL VOLTAGE 125 Other _____
 MOTOR CONTROL CENTER SYSTEM VOLTAGE _____ STARTER IDENTIFICATION _____

OVERCURRENT PROTECTION DEVICES

CONTROL POWER FUSE: MFR. Gould Shawmut TYPE PT Fuse SIZE 4800 V -2E amps
 MAIN POWER FUSE: MFR. Gould Shawmut - Amp-Trap TYPE Current Limiting Fuse SIZE 2400/4800V - 225 amps
 OVERLOAD PROTECTION: _____ TYPE _____ TESTED YES NO

INSTRUMENT TRANSFORMER DATA

CONTROL POWER TRANSFORMER: MFR. Siemens Energy VA RATING 115 TYPE CPT VOLTAGE 4000
 CURRENT TRANSFORMER: MFR. _____ RATIO :5 TYPE _____ CAT. NO. _____

Description	INSPECTED	CONDITION	CLEAN/LUBE
OVERALL CLEANLINESS	<input checked="" type="checkbox"/>	Good	
INSULATING MEMBERS	<input checked="" type="checkbox"/>	Good	
MECHANICAL CONNECTIONS	<input checked="" type="checkbox"/>	Good	
STRUCTURAL MEMBERS	<input checked="" type="checkbox"/>	Good	
CUBICLE	<input checked="" type="checkbox"/>	Good	
RACKING DEVICES	<input checked="" type="checkbox"/>	Good	
SHUTTER	<input checked="" type="checkbox"/>	Good	

Description	INSPECTED	CONDITION	CLEAN/LUBE
OPERATING MECHANISM	<input checked="" type="checkbox"/>	Good	
CONTACT FINGERS	<input checked="" type="checkbox"/>	Good	
VACUUM INTERRUPTER	<input checked="" type="checkbox"/>	Good	
CONTACT EROSION INDICATOR	<input checked="" type="checkbox"/>	Good	
CONTACT SEQUENCE	<input checked="" type="checkbox"/>	Good	
GROUND CONNECTIONS	<input checked="" type="checkbox"/>	Good	
AUXILIARY DEVICES	<input checked="" type="checkbox"/>	Good	

TEMPERATURE CORRECTION FACTOR TO: 20°C 40°C
 INSULATION TEST VOLTAGE 5000 KVDC TEST VOLTAGE MULTIPLIER, K1 = _____ K2 = (K1) (TCF)
 EQUIPMENT TEMPERATURE 20 °C TEMPERATURE CORRECTION FACTOR TO 20°C, TCF 1
 MILLIWATT LOSS TEST VOLTAGE _____ KVDC HIGH POTENTIAL TEST VOLTAGE _____ KVDC 12,000 KVAC

INSULATION TESTS	POLE 1	POLE 2	POLE 3
	READING	READING	READING
POLE TO POLE - CLOSED	1.02 T	1.23 T	1.41 T
POLE TO FRAME - CLOSED	470 G	578 G	609 G
LINE TO FRAME - OPEN	4.25 T	2.74 T	3.98 T
LOAD TO FRAME - OPEN	2.84 T	3.04 T	2.45 T
LINE TO LOAD - OPEN	281 G	4.26 T	4.42 T

CONTACT MEASUREMENTS

	POLE 1	POLE 2	POLE 3
POLE RESISTANCE	RDG. 92	96	100
MICRO - OHMS			
MAIN FUSE	RDG. 0.5	0.6	0.6
CPT - FUSE	20°C 1.4	1.4	

CONTROL WIRING - MEGOHMS			
READING		20°C	

		POLE 1	POLE 2	POLE 3
HIPOT - OPEN	AC	4.0	3.8	3.8
HIPOT - CLOSED	AC	4.0	4.0	4.0

TESTED BY: Matthew Falchetti / Andrew Kirk

MEDIUM VOLTAGE VACUUM MOTOR STARTER TEST



PAGE _____

COMMENTS:

DEFICIENCIES:

EQUIPMENT USED

#	Manufacturer	Model	Serial / ID Number	Type	Calibration Date	Calibration Due
1	FLUKE	FLUKE - 87V	38210208	MULTIMETER	1/14/2023	1/14/2024
2	MEGGER	10 kv	102311999	INSULATION	1/10/2023	1/10/2024
3	MEGGER	1006-603	102305978	DLRO10HD	1/14/2023	1/14/2024
4	HVI	50kV AC HIPOT	2534	AC - HIPOT	1/8/2023	1/8/2024

MEDIUM VOLTAGE VACUUM MOTOR STARTER TEST



CUSTOMER Orange Cogen PAGE _____
 ADDRESS 1901 S. Clear Springs Rd; Bartow FL 33830 DATE 10/2/2023
 OWNER Orange Cogen; 1901 S. Clear Springs Rd; Bartow FL 33830 JOB # OCFL2310066
 SITE Orange Cogen TEST STATUS _____ Pass
 SUBSTATION Main MCC ASSET ID 350 HP/013D140 Primary Circ Water Pump - 2
 EQUIPMENT 4160 Starters AMBIENT TEMPERATURE 70 °F HUMIDITY 61 %

NAMEPLATE DATA

MANUFACTURER Siemens SERIAL NO. RAL-71921-2FC-072994 TYPE AC Contactor -FM
 CATALOG NO. 93H3533034A3A STARTER SIZE 4800 FORM N/A
 SERIES 93H35 AC Contactor MAXIMUM VOLTAGE 5000 INT. RATING kA @ kV
 OPERATING VOLTAGE 4160 CONTROL VOLTAGE 125 Other _____
 MOTOR CONTROL CENTER SYSTEM VOLTAGE _____ STARTER IDENTIFICATION _____

OVERCURRENT PROTECTION DEVICES

CONTROL POWER FUSE: MFR. Gould Shawmut TYPE PT Fuse SIZE 4800 V -2E amps
 MAIN POWER FUSE: MFR. Gould Shawmut - Amp-Trap TYPE Current Limiting Fuse SIZE 2400/4800V - 225 amps
 OVERLOAD PROTECTION: _____ TYPE _____ TESTED YES NO

INSTRUMENT TRANSFORMER DATA

CONTROL POWER TRANSFORMER: MFR. Siemens Energy VA RATING 115 TYPE CPT VOLTAGE 4000
 CURRENT TRANSFORMER: MFR. _____ RATIO :5 TYPE _____ CAT. NO. _____

Description	INSPECTED	CONDITION	CLEAN/LUBE
OVERALL CLEANLINESS	<input checked="" type="checkbox"/>	Good	
INSULATING MEMBERS	<input checked="" type="checkbox"/>	Good	
MECHANICAL CONNECTIONS	<input checked="" type="checkbox"/>	Good	
STRUCTURAL MEMBERS	<input checked="" type="checkbox"/>	Good	
CUBICLE	<input checked="" type="checkbox"/>	Good	
RACKING DEVICES	<input checked="" type="checkbox"/>	Good	
SHUTTER	<input checked="" type="checkbox"/>	Good	

Description	INSPECTED	CONDITION	CLEAN/LUBE
OPERATING MECHANISM	<input checked="" type="checkbox"/>	Good	
CONTACT FINGERS	<input checked="" type="checkbox"/>	Good	
VACUUM INTERRUPTER	<input checked="" type="checkbox"/>	Good	
CONTACT EROSION INDICATOR	<input checked="" type="checkbox"/>	Good	
CONTACT SEQUENCE	<input checked="" type="checkbox"/>	Good	
GROUND CONNECTIONS	<input checked="" type="checkbox"/>	Good	
AUXILIARY DEVICES	<input checked="" type="checkbox"/>	Good	

TEMPERATURE CORRECTION FACTOR TO: 20°C 40°C
 INSULATION TEST VOLTAGE 5000 KVDC TEST VOLTAGE MULTIPLIER, K1 = _____ K2 = (K1) (TCF)
 EQUIPMENT TEMPERATURE 20 °C TEMPERATURE CORRECTION FACTOR TO 20°C, TCF 1
 MILLIWATT LOSS TEST VOLTAGE _____ KVDC HIGH POTENTIAL TEST VOLTAGE _____ KVDC 12,000 KVAC

INSULATION TESTS	POLE 1	POLE 2	POLE 3
	READING	READING	READING
POLE TO POLE - CLOSED	12.71 T	11.18 T	10.45 T
POLE TO FRAME - CLOSED	5.27 T	3.40 T	
LINE TO FRAME - OPEN	7.64 T	5.57 T	3.94 T
LOAD TO FRAME - OPEN	4.49 T	6.82 T	4.55 T
LINE TO LOAD - OPEN	5.82 T	7.52 T	9.62 T

CONTACT MEASUREMENTS

	POLE 1	POLE 2	POLE 3
POLE RESISTANCE	RDG. 90	92	94
MICRO - OHMS			
MAIN FUSE	RDG. 0.7	0.7	0.8
CPT - FUSE	20°C 1.1	1.3	

CONTROL WIRING - MEGOHMS			
READING		20°C	

		POLE 1	POLE 2	POLE 3
HIPOT - OPEN	AC	4.2	4.0	4.0
HIPOT - CLOSED	AC	3.8	3.8	3.8

TESTED BY: Matthew Falchetti / Andrew Kirk

MEDIUM VOLTAGE VACUUM MOTOR STARTER TEST



PAGE _____

COMMENTS:

DEFICIENCIES:

EQUIPMENT USED:

#	Manufacturer	Model	Serial / ID Number	Type	Calibration Date	Calibration Due
1	FLUKE	FLUKE - 87V	38210208	MULTIMETER	1/14/2023	1/14/2024
2	MEGGER	10 kv	102311999	INSULATION	1/10/2023	1/10/2024
3	MEGGER	1006-603	102305978	DLRO10HD	1/14/2023	1/14/2024
4	HVI	50kV AC HIPOT	2534	AC - HIPOT	1/8/2023	1/8/2024

MEDIUM VOLTAGE VACUUM MOTOR STARTER TEST



CUSTOMER Orange Cogen PAGE _____
 ADDRESS 1901 S. Clear Springs Rd; Bartow FL 33830 DATE 10/2/2023
 OWNER Orange Cogen; 1901 S. Clear Springs Rd; Bartow FL 33830 JOB # OCFL2310066
 SITE Orange Cogen TEST STATUS _____ Pass
 SUBSTATION Main MCC ASSET ID 350 HP/013D130 Primary Circ- Water Pump -1
 EQUIPMENT 4160 Starters AMBIENT TEMPERATURE 70 °F HUMIDITY 61 %

NAMEPLATE DATA

MANUFACTURER Siemens SERIAL NO. RAL-71921-2RB-072894 TYPE AC Contactor -FM
 CATALOG NO. 93H3533034A3A STARTER SIZE 4800 FORM N/A
 SERIES 93H35 AC Contactor MAXIMUM VOLTAGE 5000 INT. RATING kA @ kV
 OPERATING VOLTAGE 4160 CONTROL VOLTAGE 125 Other _____
 MOTOR CONTROL CENTER SYSTEM VOLTAGE _____ STARTER IDENTIFICATION _____

OVERCURRENT PROTECTION DEVICES

CONTROL POWER FUSE: MFR. Gould Shawmut TYPE PT Fuse SIZE 4800 V -2E amps
 MAIN POWER FUSE: MFR. Gould Shawmut - Amp-Trap TYPE Current Limiting Fuse SIZE 2400/4800V - 225 amps
 OVERLOAD PROTECTION: _____ TYPE _____ TESTED YES NO

INSTRUMENT TRANSFORMER DATA

CONTROL POWER TRANSFORMER: MFR. Siemens Energy VA RATING 115 TYPE CPT VOLTAGE 4000
 CURRENT TRANSFORMER: MFR. _____ RATIO :5 TYPE _____ CAT. NO. _____

Description	INSPECTED	CONDITION	CLEAN/LUBE
OVERALL CLEANLINESS	<input checked="" type="checkbox"/>	Good	
INSULATING MEMBERS	<input checked="" type="checkbox"/>	Good	
MECHANICAL CONNECTIONS	<input checked="" type="checkbox"/>	Good	
STRUCTURAL MEMBERS	<input checked="" type="checkbox"/>	Good	
CUBICLE	<input checked="" type="checkbox"/>	Good	
RACKING DEVICES	<input checked="" type="checkbox"/>	Good	
SHUTTER	<input checked="" type="checkbox"/>	Good	

Description	INSPECTED	CONDITION	CLEAN/LUBE
OPERATING MECHANISM	<input checked="" type="checkbox"/>	Good	
CONTACT FINGERS	<input checked="" type="checkbox"/>	Good	
VACUUM INTERRUPTER	<input checked="" type="checkbox"/>	Good	
CONTACT EROSION INDICATOR	<input checked="" type="checkbox"/>	Good	
CONTACT SEQUENCE	<input checked="" type="checkbox"/>	Good	
GROUND CONNECTIONS	<input checked="" type="checkbox"/>	Good	
AUXILIARY DEVICES	<input checked="" type="checkbox"/>	Good	

TEMPERATURE CORRECTION FACTOR TO: 20°C 40°C
 INSULATION TEST VOLTAGE 5000 KVDC TEST VOLTAGE MULTIPLIER, K1 = _____ K2 = (K1) (TCF)
 EQUIPMENT TEMPERATURE 20 °C TEMPERATURE CORRECTION FACTOR TO 20°C, TCF 1
 MILLIWATT LOSS TEST VOLTAGE _____ KVDC HIGH POTENTIAL TEST VOLTAGE _____ KVDC 12,000 KVAC

INSULATION TESTS	POLE 1	POLE 2	POLE 3
	READING	READING	READING
POLE TO POLE - CLOSED	6.82 T	5.42 T	10.01 T
POLE TO FRAME - CLOSED	4.76 T	2.50 T	3.91 T
LINE TO FRAME - OPEN	4.88 T	8.64 T	5.69 T
LOAD TO FRAME - OPEN	1.64 T	4.41 T	1.47 T
LINE TO LOAD - OPEN	8.02 T	7.44 T	3.73 T

CONTACT MEASUREMENTS

	POLE 1	POLE 2	POLE 3
POLE RESISTANCE	RDG. 110	115	120
MICRO - OHMS			
MAIN FUSE	RDG. 0.7	0.8	0.8
CPT - FUSE	20°C 1.6	1.6	

CONTROL WIRING - MEGOHMS			
READING		20°C	

		POLE 1	POLE 2	POLE 3
HIPOT - OPEN	AC	4.0	4.2	4.2
HIPOT - CLOSED	AC	4.0	4.0	4.2

TESTED BY: Matthew Falchetti / Andrew Kirk

MEDIUM VOLTAGE VACUUM MOTOR STARTER TEST



PAGE _____

COMMENTS:

DEFICIENCIES:

EQUIPMENT USED

#	Manufacturer	Model	Serial / ID Number	Type	Calibration Date	Calibration Due
1	FLUKE	FLUKE - 87V	38210208	MULTIMETER	1/14/2023	1/14/2024
2	MEGGER	10 kv	102311999	INSULATION	1/10/2023	1/10/2024
3	MEGGER	1006-603	102305978	DLRO10HD	1/14/2023	1/14/2024
4	HVI	50kV AC HIPOT	2534	AC - HIPOT	1/8/2023	1/8/2024

MEDIUM VOLTAGE VACUUM MOTOR STARTER TEST



CUSTOMER Orange Cogen PAGE _____
 ADDRESS 1901 S. Clear Springs Rd; Bartow FL 33830 DATE 10/2/2023
 OWNER Orange Cogen; 1901 S. Clear Springs Rd; Bartow FL 33830 JOB # OCFL2310066
 SITE Orange Cogen TEST STATUS _____ Pass
 SUBSTATION Main MCC ASSET ID 250 HP 006D620 Feedwater Pump - 1
 EQUIPMENT 4160 Starters AMBIENT TEMPERATURE 70 °F HUMIDITY 61 %

NAMEPLATE DATA

MANUFACTURER Siemens SERIAL NO. RAL-71921-1FB-072994 TYPE AC Contactor -FM
 CATALOG NO. 93H3533034A3A STARTER SIZE 4800 FORM N/A
 SERIES 93H35 AC Contactor MAXIMUM VOLTAGE 5000 INT. RATING kA @ kV
 OPERATING VOLTAGE 4160 CONTROL VOLTAGE 125 Other _____
 MOTOR CONTROL CENTER SYSTEM VOLTAGE _____ STARTER IDENTIFICATION _____

OVERCURRENT PROTECTION DEVICES

CONTROL POWER FUSE: MFR. Gould Shawmut TYPE PT Fuse SIZE 4800 V -2E amps
 MAIN POWER FUSE: MFR. Gould Shawmut - Amp-Trap TYPE Current Limiting Fuse SIZE 2400/4800V - 225 amps
 OVERLOAD PROTECTION: _____ TYPE _____ TESTED YES NO

INSTRUMENT TRANSFORMER DATA

CONTROL POWER TRANSFORMER: MFR. Siemens Energy VA RATING 115 TYPE CPT VOLTAGE 4000
 CURRENT TRANSFORMER: MFR. _____ RATIO :5 TYPE _____ CAT. NO. _____

Description	INSPECTED	CONDITION	CLEAN/LUBE
OVERALL CLEANLINESS	<input checked="" type="checkbox"/>	Good	
INSULATING MEMBERS	<input checked="" type="checkbox"/>	Good	
MECHANICAL CONNECTIONS	<input checked="" type="checkbox"/>	Good	
STRUCTURAL MEMBERS	<input checked="" type="checkbox"/>	Good	
CUBICLE	<input checked="" type="checkbox"/>	Good	
RACKING DEVICES	<input checked="" type="checkbox"/>	Good	
SHUTTER	<input checked="" type="checkbox"/>	Good	

Description	INSPECTED	CONDITION	CLEAN/LUBE
OPERATING MECHANISM	<input checked="" type="checkbox"/>	Good	
CONTACT FINGERS	<input checked="" type="checkbox"/>	Good	
VACUUM INTERRUPTER	<input checked="" type="checkbox"/>	Good	
CONTACT EROSION INDICATOR	<input checked="" type="checkbox"/>	Good	
CONTACT SEQUENCE	<input checked="" type="checkbox"/>	Good	
GROUND CONNECTIONS	<input checked="" type="checkbox"/>	Good	
AUXILIARY DEVICES	<input checked="" type="checkbox"/>	Good	

TEMPERATURE CORRECTION FACTOR TO: 20°C 40°C
 INSULATION TEST VOLTAGE 5000 KVDC TEST VOLTAGE MULTIPLIER, K1 = _____ K2 = (K1) (TCF)
 EQUIPMENT TEMPERATURE 20 °C TEMPERATURE CORRECTION FACTOR TO 20°C, TCF 1
 MILLIWATT LOSS TEST VOLTAGE _____ KVDC HIGH POTENTIAL TEST VOLTAGE _____ KVDC 12,000 KVAC

INSULATION TESTS	POLE 1	POLE 2	POLE 3
	READING	READING	READING
POLE TO POLE - CLOSED	8.15 T	6.58 T	5.17 T
POLE TO FRAME - CLOSED	2.33 T	4.01 T	2.41 T
LINE TO FRAME - OPEN	2.99 T	6.83 T	7.16 T
LOAD TO FRAME - OPEN	2.07 T	4.94 T	2.72 T
LINE TO LOAD - OPEN	3.51 T	4.94 T	6.17 T

CONTACT MEASUREMENTS		POLE 1	POLE 2	POLE 3
POLE RESISTANCE	RDG.	102	97	104
MICRO - OHMS				
MAIN FUSE	RDG.	0.5	0.6	0.7
CPT - FUSE	20°C	1.1	1.1	

CONTROL WIRING - MEGOHMS				
READING		20°C		
		POLE 1	POLE 2	POLE 3
HIPOT - OPEN	AC	4.0	4.0	4.0
HIPOT - CLOSED	AC	4.0	4.0	3.8

MEDIUM VOLTAGE VACUUM MOTOR STARTER TEST



PAGE _____

COMMENTS:

DEFICIENCIES:

EQUIPMENT USED

#	Manufacturer	Model	Serial / ID Number	Type	Calibration Date	Calibration Due
1	FLUKE	FLUKE - 87V	38210208	MULTIMETER	1/14/2023	1/14/2024
2	MEGGER	10 kv	102311999	INSULATION	1/10/2023	1/10/2024
3	MEGGER	1006-603	102305978	DLRO10HD	1/14/2023	1/14/2024
4	HVI	50kV AC HIPOT	2534	AC - HIPOT	1/8/2023	1/8/2024

MEDIUM VOLTAGE VACUUM MOTOR STARTER TEST



CUSTOMER Orange Cogen PAGE _____
 ADDRESS 1901 S. Clear Springs Rd; Bartow FL 33830 DATE 10/2/2023
 OWNER Orange Cogen; 1901 S. Clear Springs Rd; Bartow FL 33830 JOB # OCFL2310066
 SITE Orange Cogen TEST STATUS _____ Pass
 SUBSTATION Main MCC ASSET ID 250 HP 006D635 Feedwater Pump - 4
 EQUIPMENT 4160 Starters AMBIENT TEMPERATURE _____ °F HUMIDITY 61 %

NAMEPLATE DATA

MANUFACTURER Siemens SERIAL NO. RAL-71921-10FB-072894 TYPE AC Contactor -FM
 CATALOG NO. 93H3533034A3A STARTER SIZE 4800 FORM N/A
 SERIES 93H35 AC Contactor MAXIMUM VOLTAGE 5000 INT. RATING _____ kA @ _____ kV
 OPERATING VOLTAGE 4160 CONTROL VOLTAGE 125 Other _____
 MOTOR CONTROL CENTER SYSTEM VOLTAGE _____ STARTER IDENTIFICATION _____

OVERCURRENT PROTECTION DEVICES

CONTROL POWER FUSE: MFR. Gould Shawmut TYPE PT Fuse SIZE 4800 V -2E amps
 MAIN POWER FUSE: MFR. Gould Shawmut - Amp-Trap TYPE Current Limiting Fuse SIZE 2400/4800V - 225 amps
 OVERLOAD PROTECTION: _____ TYPE _____ TESTED YES NO

INSTRUMENT TRANSFORMER DATA

CONTROL POWER TRANSFORMER: MFR. Siemens Energy VA RATING 115 TYPE CPT VOLTAGE 4000
 CURRENT TRANSFORMER: MFR. _____ RATIO _____ :5 TYPE _____ CAT. NO. _____

Description	INSPECTED	CONDITION	CLEAN/LUBE
OVERALL CLEANLINESS	<input checked="" type="checkbox"/>	Good	
INSULATING MEMBERS	<input checked="" type="checkbox"/>	Good	
MECHANICAL CONNECTIONS	<input checked="" type="checkbox"/>	Good	
STRUCTURAL MEMBERS	<input checked="" type="checkbox"/>	Good	
CUBICLE	<input checked="" type="checkbox"/>	Good	
RACKING DEVICES	<input checked="" type="checkbox"/>	Good	
SHUTTER	<input checked="" type="checkbox"/>	Good	

Description	INSPECTED	CONDITION	CLEAN/LUBE
OPERATING MECHANISM	<input checked="" type="checkbox"/>	Good	
CONTACT FINGERS	<input checked="" type="checkbox"/>	Good	
VACUUM INTERRUPTER	<input checked="" type="checkbox"/>	Good	
CONTACT EROSION INDICATOR	<input checked="" type="checkbox"/>	Good	
CONTACT SEQUENCE	<input checked="" type="checkbox"/>	Good	
GROUND CONNECTIONS	<input checked="" type="checkbox"/>	Good	
AUXILIARY DEVICES	<input checked="" type="checkbox"/>	Good	

TEMPERATURE CORRECTION FACTOR TO: 20°C 40°C
 INSULATION TEST VOLTAGE 5000 KVDC TEST VOLTAGE MULTIPLIER, K1 = _____ K2 = (K1) (TCF)
 EQUIPMENT TEMPERATURE 20 °C TEMPERATURE CORRECTION FACTOR TO 20°C, TCF 1
 MILLIWATT LOSS TEST VOLTAGE _____ KVDC HIGH POTENTIAL TEST VOLTAGE _____ KVDC 12,000 KVAC

INSULATION TESTS	POLE 1	POLE 2	POLE 3
	READING	READING	READING
POLE TO POLE - CLOSED	4.62 T	4.75 T	5.13 T
POLE TO FRAME - CLOSED	2.19 T	1.75 T	1.35 T
LINE TO FRAME - OPEN	3.83 T	5.40 T	5.83 T
LOAD TO FRAME - OPEN	3.98 T	3.20 T	5.09 T
LINE TO LOAD - OPEN	774 G	1.20 T	4.51 T

CONTACT MEASUREMENTS

	POLE 1	POLE 2	POLE 3
POLE RESISTANCE	RDG. 90	97	102
MICRO - OHMS			
MAIN FUSE	RDG. 0.7	0.9	0.8
CPT - FUSE	20°C 1.3	1.3	

CONTROL WIRING - MEGOHMS			
READING		20°C	

		POLE 1	POLE 2	POLE 3
HIPOT - OPEN	AC	3.8	4.0	4.0
HIPOT - CLOSED	AC	4.0	4.0	4.0

TESTED BY: Matthew Falchetti / Andrew Kirk

MEDIUM VOLTAGE VACUUM MOTOR STARTER TEST



PAGE _____

COMMENTS:

DEFICIENCIES:

EQUIPMENT USED

#	Manufacturer	Model	Serial / ID Number	Type	Calibration Date	Calibration Due
1	FLUKE	FLUKE - 87V	38210208	MULTIMETER	1/14/2023	1/14/2024
2	MEGGER	10 kv	102311999	INSULATION	1/10/2023	1/10/2024
3	MEGGER	1006-603	102305978	DLRO10HD	1/14/2023	1/14/2024
4	HVI	50kV AC HIPOT	2534	AC - HIPOT	1/8/2023	1/8/2024

MEDIUM VOLTAGE VACUUM MOTOR STARTER TEST



CUSTOMER Orange Cogen PAGE _____
 ADDRESS 1901 S. Clear Springs Rd; Bartow FL 33830 DATE 10/2/2023
 OWNER Orange Cogen; 1901 S. Clear Springs Rd; Bartow FL 33830 JOB # OCFL2310066
 SITE Orange Cogen TEST STATUS _____ Pass
 SUBSTATION Main MCC ASSET ID 350 HP/013D150 Primary Circ Water Pump - 3
 EQUIPMENT 4160 Starters AMBIENT TEMPERATURE 70 °F HUMIDITY 61 %

NAMEPLATE DATA

MANUFACTURER Siemens SERIAL NO. RAL-71921-11FB-072894 TYPE AC Contactor -FM
 CATALOG NO. 93H3533034A3A STARTER SIZE 4800 FORM N/A
 SERIES 93H35 AC Contactor MAXIMUM VOLTAGE 5000 INT. RATING kA @ kV
 OPERATING VOLTAGE 4160 CONTROL VOLTAGE 125 Other _____
 MOTOR CONTROL CENTER SYSTEM VOLTAGE _____ STARTER IDENTIFICATION _____

OVERCURRENT PROTECTION DEVICES

CONTROL POWER FUSE: MFR. Gould Shawmut TYPE PT Fuse SIZE 4800 V -2E amps
 MAIN POWER FUSE: MFR. Gould Shawmut - Amp-Trap TYPE Current Limiting Fuse SIZE 2400/4800V - 225 amps
 OVERLOAD PROTECTION: _____ TYPE _____ TESTED YES NO

INSTRUMENT TRANSFORMER DATA

CONTROL POWER TRANSFORMER: MFR. Siemens Energy VA RATING 115 TYPE CPT VOLTAGE 4000
 CURRENT TRANSFORMER: MFR. _____ RATIO :5 TYPE _____ CAT. NO. _____

Description	INSPECTED	CONDITION	CLEAN/LUBE
OVERALL CLEANLINESS	<input checked="" type="checkbox"/>	Good	
INSULATING MEMBERS	<input checked="" type="checkbox"/>	Good	
MECHANICAL CONNECTIONS	<input checked="" type="checkbox"/>	Good	
STRUCTURAL MEMBERS	<input checked="" type="checkbox"/>	Good	
CUBICLE	<input checked="" type="checkbox"/>	Good	
RACKING DEVICES	<input checked="" type="checkbox"/>	Good	
SHUTTER	<input checked="" type="checkbox"/>	Good	

Description	INSPECTED	CONDITION	CLEAN/LUBE
OPERATING MECHANISM	<input checked="" type="checkbox"/>	Good	
CONTACT FINGERS	<input checked="" type="checkbox"/>	Good	
VACUUM INTERRUPTER	<input checked="" type="checkbox"/>	Good	
CONTACT EROSION INDICATOR	<input checked="" type="checkbox"/>	Good	
CONTACT SEQUENCE	<input checked="" type="checkbox"/>	Good	
GROUND CONNECTIONS	<input checked="" type="checkbox"/>	Good	
AUXILIARY DEVICES	<input checked="" type="checkbox"/>	Good	

TEMPERATURE CORRECTION FACTOR TO: 20°C 40°C
 INSULATION TEST VOLTAGE 5000 KVDC TEST VOLTAGE MULTIPLIER, K1 = _____ K2 = (K1) (TCF)
 EQUIPMENT TEMPERATURE 20 °C TEMPERATURE CORRECTION FACTOR TO 20°C, TCF 1
 MILLIWATT LOSS TEST VOLTAGE _____ KVDC HIGH POTENTIAL TEST VOLTAGE _____ KVDC 12,000 KVAC

INSULATION TESTS	POLE 1	POLE 2	POLE 3
	READING	READING	READING
POLE TO POLE - CLOSED	3.84 T	4.65 T	8.67 T
POLE TO FRAME - CLOSED	5.48 T	8.34 T	9.40 T
LINE TO FRAME - OPEN	4.82 T	3.02 T	2.19 T
LOAD TO FRAME - OPEN	3.21 T	3.49 T	3.05 T
LINE TO LOAD - OPEN	4.37 T	5.51 T	4.43 T

CONTACT MEASUREMENTS

	POLE 1	POLE 2	POLE 3
POLE RESISTANCE	RDG. 120	100	111
MICRO - OHMS			
MAIN FUSE	RDG. 1.8	1.1	1.1
CPT - FUSE	20°C 1.4	1.7	

CONTROL WIRING - MEGOHMS			
READING		20°C	

		POLE 1	POLE 2	POLE 3
HIPOT - OPEN	AC	4.0	4.0	4.0
HIPOT - CLOSED	AC	4.0	4.0	4.0

TESTED BY: Matthew Falchetti / Andrew Kirk

MEDIUM VOLTAGE VACUUM MOTOR STARTER TEST



PAGE _____

COMMENTS:

DEFICIENCIES:

EQUIPMENT USED:

#	Manufacturer	Model	Serial / ID Number	Type	Calibration Date	Calibration Due
1	FLUKE	FLUKE - 87V	38210208	MULTIMETER	1/14/2023	1/14/2024
2	MEGGER	10 kv	102311999	INSULATION	1/10/2023	1/10/2024
3	MEGGER	1006-603	102305978	DLRO10HD	1/14/2023	1/14/2024
4	HVI	50kV AC HIPOT	2534	AC - HIPOT	1/8/2023	1/8/2024

MEDIUM VOLTAGE VACUUM MOTOR STARTER TEST



CUSTOMER Orange Cogen PAGE _____
 ADDRESS 1901 S. Clear Springs Rd; Bartow FL 33830 DATE 10/2/2023
 OWNER Orange Cogen; 1901 S. Clear Springs Rd; Bartow FL 33830 JOB # OCFL2310066
 SITE Orange Cogen TEST STATUS _____ Pass
 SUBSTATION Main MCC ASSET ID 250 HP/020D130 Gas BSTR Compressor - 1
 EQUIPMENT 4160 Starters AMBIENT TEMPERATURE 70 °F HUMIDITY 61 %

NAMEPLATE DATA

MANUFACTURER Siemens SERIAL NO. RAL-71921-1RC-072894 TYPE AC Contactor -FM
 CATALOG NO. 93H3533034A3A STARTER SIZE 4800 FORM N/A
 SERIES 93H35 AC Contactor MAXIMUM VOLTAGE 5000 INT. RATING kA @ kV
 OPERATING VOLTAGE 4160 CONTROL VOLTAGE 125 Other _____
 MOTOR CONTROL CENTER SYSTEM VOLTAGE _____ STARTER IDENTIFICATION _____

OVERCURRENT PROTECTION DEVICES

CONTROL POWER FUSE: MFR. Gould Shawmut TYPE PT Fuse SIZE 4800 V -2E amps
 MAIN POWER FUSE: MFR. Gould Shawmut - Amp-Trap TYPE Current Limiting Fuse SIZE 2400/4800V - 225 amps
 OVERLOAD PROTECTION: _____ TYPE _____ TESTED YES NO

INSTRUMENT TRANSFORMER DATA

CONTROL POWER TRANSFORMER: MFR. Siemens Energy VA RATING 115 TYPE CPT VOLTAGE 4000
 CURRENT TRANSFORMER: MFR. _____ RATIO :5 TYPE _____ CAT. NO. _____

Description	INSPECTED	CONDITION	CLEAN/LUBE
OVERALL CLEANLINESS	<input checked="" type="checkbox"/>	Good	
INSULATING MEMBERS	<input checked="" type="checkbox"/>	Good	
MECHANICAL CONNECTIONS	<input checked="" type="checkbox"/>	Good	
STRUCTURAL MEMBERS	<input checked="" type="checkbox"/>	Good	
CUBICLE	<input checked="" type="checkbox"/>	Good	
RACKING DEVICES	<input checked="" type="checkbox"/>	Good	
SHUTTER	<input checked="" type="checkbox"/>	Good	

Description	INSPECTED	CONDITION	CLEAN/LUBE
OPERATING MECHANISM	<input checked="" type="checkbox"/>	Good	
CONTACT FINGERS	<input checked="" type="checkbox"/>	Good	
VACUUM INTERRUPTER	<input checked="" type="checkbox"/>	Good	
CONTACT EROSION INDICATOR	<input checked="" type="checkbox"/>	Good	
CONTACT SEQUENCE	<input checked="" type="checkbox"/>	Good	
GROUND CONNECTIONS	<input checked="" type="checkbox"/>	Good	
AUXILIARY DEVICES	<input checked="" type="checkbox"/>	Good	

TEMPERATURE CORRECTION FACTOR TO: 20°C 40°C
 INSULATION TEST VOLTAGE 5000 KVDC TEST VOLTAGE MULTIPLIER, K1 = _____ K2 = (K1) (TCF)
 EQUIPMENT TEMPERATURE 20 °C TEMPERATURE CORRECTION FACTOR TO 20°C, TCF 1
 MILLIWATT LOSS TEST VOLTAGE _____ KVDC HIGH POTENTIAL TEST VOLTAGE _____ KVDC 12,000 KVAC

INSULATION TESTS	POLE 1	POLE 2	POLE 3
	READING	READING	READING
POLE TO POLE - CLOSED	2.88 T	3.49 T	4.51 T
POLE TO FRAME - CLOSED	1.43 T	1.39 T	1.27 T
LINE TO FRAME - OPEN	2.31 T	1.97 T	3.00 T
LOAD TO FRAME - OPEN	1.40 T	1.27 T	2.09 T
LINE TO LOAD - OPEN	1.25 T	2.27 T	3.77 T

CONTACT MEASUREMENTS

	POLE 1	POLE 2	POLE 3
POLE RESISTANCE	RDG. 100	102	103
MICRO - OHMS			
MAIN FUSE	RDG. 0.4	0.4	0.5
CPT - FUSE	20°C 0.8	0.8	

CONTROL WIRING - MEGOHMS			
READING		20°C	

		POLE 1	POLE 2	POLE 3
HIPOT - OPEN	AC	3.8	4.0	3.8
HIPOT - CLOSED	AC	3.8	4.0	4.0

TESTED BY: Matthew Falchetti / Andrew Kirk

MEDIUM VOLTAGE VACUUM MOTOR STARTER TEST



PAGE _____

COMMENTS:

DEFICIENCIES:

EQUIPMENT USED

#	Manufacturer	Model	Serial / ID Number	Type	Calibration Date	Calibration Due
1	FLUKE	FLUKE - 87V	38210208	MULTIMETER	1/14/2023	1/14/2024
2	MEGGER	10 kv	102311999	INSULATION	1/10/2023	1/10/2024
3	MEGGER	1006-603	102305978	DLRO10HD	1/14/2023	1/14/2024
4	HVI	50kV AC HIPOT	2534	AC - HIPOT	1/8/2023	1/8/2024

MEDIUM VOLTAGE VACUUM MOTOR STARTER TEST



CUSTOMER Orange Cogen PAGE _____
 ADDRESS 1901 S. Clear Springs Rd; Bartow FL 33830 DATE 10/2/2023
 OWNER Orange Cogen; 1901 S. Clear Springs Rd; Bartow FL 33830 JOB # OCFL2310066
 SITE Orange Cogen TEST STATUS _____ Pass
 SUBSTATION Main MCC ASSET ID 250 HP 006D625 Feedwater Pump - 2
 EQUIPMENT 4160 Starters AMBIENT TEMPERATURE 70 °F HUMIDITY 61 %

NAMEPLATE DATA

MANUFACTURER Siemens SERIAL NO. RAL-71921-1FC-072994 TYPE AC Contactor -FM
 CATALOG NO. 93H3533034A3A STARTER SIZE 4800 FORM N/A
 SERIES 93H35 AC Contactor MAXIMUM VOLTAGE 5000 INT. RATING kA @ kV
 OPERATING VOLTAGE 4160 CONTROL VOLTAGE 125 Other _____
 MOTOR CONTROL CENTER SYSTEM VOLTAGE _____ STARTER IDENTIFICATION _____

OVERCURRENT PROTECTION DEVICES

CONTROL POWER FUSE: MFR. Gould Shawmut TYPE PT Fuse SIZE 4800 V -2E amps
 MAIN POWER FUSE: MFR. Gould Shawmut - Amp-Trap TYPE Current Limiting Fuse SIZE 2400/4800V - 225 amps
 OVERLOAD PROTECTION: _____ TYPE _____ TESTED YES NO

INSTRUMENT TRANSFORMER DATA

CONTROL POWER TRANSFORMER: MFR. Siemens Energy VA RATING 115 TYPE CPT VOLTAGE 4000
 CURRENT TRANSFORMER: MFR. _____ RATIO :5 TYPE _____ CAT. NO. _____

Description	INSPECTED	CONDITION	CLEAN/LUBE
OVERALL CLEANLINESS	<input checked="" type="checkbox"/>	Good	
INSULATING MEMBERS	<input checked="" type="checkbox"/>	Good	
MECHANICAL CONNECTIONS	<input checked="" type="checkbox"/>	Good	
STRUCTURAL MEMBERS	<input checked="" type="checkbox"/>	Good	
CUBICLE	<input checked="" type="checkbox"/>	Good	
RACKING DEVICES	<input checked="" type="checkbox"/>	Good	
SHUTTER	<input checked="" type="checkbox"/>	Good	

Description	INSPECTED	CONDITION	CLEAN/LUBE
OPERATING MECHANISM	<input checked="" type="checkbox"/>	Good	
CONTACT FINGERS	<input checked="" type="checkbox"/>	Good	
VACUUM INTERRUPTER	<input checked="" type="checkbox"/>	Good	
CONTACT EROSION INDICATOR	<input checked="" type="checkbox"/>	Good	
CONTACT SEQUENCE	<input checked="" type="checkbox"/>	Good	
GROUND CONNECTIONS	<input checked="" type="checkbox"/>	Good	
AUXILIARY DEVICES	<input checked="" type="checkbox"/>	Good	

TEMPERATURE CORRECTION FACTOR TO: 20°C 40°C
 INSULATION TEST VOLTAGE 5000 KVDC TEST VOLTAGE MULTIPLIER, K1 = _____ K2 = (K1) (TCF)
 EQUIPMENT TEMPERATURE 20 °C TEMPERATURE CORRECTION FACTOR TO 20°C, TCF 1
 MILLIWATT LOSS TEST VOLTAGE _____ KVDC HIGH POTENTIAL TEST VOLTAGE _____ KVDC 12,000 KVAC

INSULATION TESTS	POLE 1	POLE 2	POLE 3
	READING	READING	READING
POLE TO POLE - CLOSED	5.23 T	4.73 T	5.87 T
POLE TO FRAME - CLOSED	2.30 T	2.54 T	2.61 T
LINE TO FRAME - OPEN	2.58 T	996 G	1.43 T
LOAD TO FRAME - OPEN	948 G	847 G	1.18 T
LINE TO LOAD - OPEN	1.74 T	2.33 T	2.72 T

CONTACT MEASUREMENTS

	POLE 1	POLE 2	POLE 3
POLE RESISTANCE	RDG. 110	161	154
MICRO - OHMS			
MAIN FUSE	RDG. 0.8	0.8	0.8
CPT - FUSE	20°C 1.1	1.1	

CONTROL WIRING - MEGOHMS			
READING		20°C	

		POLE 1	POLE 2	POLE 3
HIPOT - OPEN	AC	4.2	4.2	4.0
HIPOT - CLOSED	AC	4.0	4.0	4.2

TESTED BY: Matthew Falchetti / Andrew Kirk

MEDIUM VOLTAGE VACUUM MOTOR STARTER TEST



PAGE _____

COMMENTS:

DEFICIENCIES:

EQUIPMENT USED

#	Manufacturer	Model	Serial / ID Number	Type	Calibration Date	Calibration Due
1	FLUKE	FLUKE - 87V	38210208	MULTIMETER	1/14/2023	1/14/2024
2	MEGGER	10 kv	102311999	INSULATION	1/10/2023	1/10/2024
3	MEGGER	1006-603	102305978	DLRO10HD	1/14/2023	1/14/2024
4	HVI	50kV AC HIPOT	2534	AC - HIPOT	1/8/2023	1/8/2024

VACUUM CIRCUIT BREAKER TEST



CUSTOMER Orange Cogen PAGE _____
 ADDRESS 1901 S. Clear Springs Rd; Bartow FL 33830 DATE 9/30/2023
 OWNER Orange Cogen; 1901 S. Clear Springs Rd; Bartow FL 33830 JOB # OCFL2310066
 SITE Orange Cogen TEST STATUS _____ Pass
 SUBSTATION Main MCC ASSET ID Main Breaker - 52-2A
 EQUIPMENT 5kV Breakers AMBIENT TEMPERATURE 75 °F HUMIDITY 61 %

MANUFACTURER Siemens SERIAL NUMBER R-99515A-4
 TYPE 5-GMI-250-1200-58 MODEL NO. AC High Voltage Circuit Breaker DATE MANUFACTURED 1994
 MAXIMUM VOLTAGE 5000 kV AMPACITY 1200 OPERATING VOLTAGE 4.76 kV
 INTERRUPTING CAPACITY 29 kA @ 1.24 kV TO _____ kV = _____ mVA

Description	INSPECTED	CONDITION	CLEAN/LUBE
OVERALL CLEANLINESS	✓	Good	
INSULATING MEMBERS	✓	Good	
MECHANICAL CONNECTIONS	✓	Good	
STRUCTURAL MEMBERS	✓	Good	
CUBICLE	✓	Good	
RACKING DEVICES	✓	Good	
SHUTTER	✓	Good	

Description	INSPECTED	CONDITION	CLEAN/LUBE
CONTACT FINGERS	✓	Good	
VACUUM BOTTLE	✓	Good	
CONTACT EROSION INDICATOR	✓	Good	
OPERATING MECHANISM	✓	Good	
CONTACT SEQUENCE	✓	Good	
GROUND CONNECTION	✓	Good	
AUXILIARY DEVICES	✓	Good	

INSULATION TEST VOLTAGE 5,000 kVDC EQUIPMENT TEMPERATURE 20 °C
 MILLIWATT LOSS TEST VOLTAGE _____ kVAC HIGH POTENTIAL TEST VOLTAGE 14000 kVAC

INSULATION RESISTANCE	POLE 1	POLE 2	POLE 3
	READING	READING	READING
POLE TO POLE (CLOSED)	1.37 T	1.05 T	1.31 T
POLE TO FRAME (CLOSED)	650 G	653 G	427 G
LINE TO FRAME (OPEN)	2.13 T	1.87 T	1.33 T
LOAD TO FRAME (OPEN)	2.27 T	2.07 T	1.61 T
LINE TO LOAD (OPEN)	1.37 T	1.81 T	1.27 T

	POLE 1	POLE 2	POLE 3
HIPOT - CLOSED kVAC	9.2	9.4	9.2
HIPOT - OPEN kVAC	9.4	9.2	9.4

CONTACT MEASUREMENTS	POLE 1	POLE 2	POLE 3
FUSES - OHMS			
CONTACT RESISTANCE MICRO-OHMS	RDG. 22	15	24

COUNTER READING: BEG. 00800
 END 00801

COMMENTS: _____
 DEFICIENCIES: _____

EQUIPMENT USED	#	Manufacturer	Model	Serial / ID Number	Type	Calibration Date	Calibration Due
	1	FLUKE	FLUKE - 87V	38210208	MULTIMETER	12/14/2022	12/14/2023
	2	MEGGER	10 kV	102345653	INSULATION F	12/20/2022	1/1/1970
	3	MEGGER	1006-603	102354950	DLRO10HD	12/20/2022	1/1/1970
	4	HVI	50kV AC HIPOT	2534	AC - HIPOT	12/8/2022	1/1/1970

TESTED BY: Chris Weedman / Andrew Kirk

VACUUM CIRCUIT BREAKER TEST



CUSTOMER Orange Cogen PAGE _____
 ADDRESS 1901 S. Clear Springs Rd; Bartow FL 33830 DATE 9/30/2023
 OWNER Orange Cogen; 1901 S. Clear Springs Rd; Bartow FL 33830 JOB # OCFL2310066
 SITE Orange Cogen TEST STATUS _____ Pass
 SUBSTATION Main MCC ASSET ID Station Service Trans. 216E220
 EQUIPMENT 5kV Breakers AMBIENT TEMPERATURE 75 °F HUMIDITY 61 %

MANUFACTURER Siemens SERIAL NUMBER R-99515A-6
 TYPE 5-GMI-250-1200-58 MODEL NO. AC High Voltage Circuit Breaker DATE MANUFACTURED 1994
 MAXIMUM VOLTAGE 5000 kV AMPACITY 1200 OPERATING VOLTAGE 4.76 kV
 INTERRUPTING CAPACITY 29 kA @ 1.24 kV TO _____ kV = _____ mVA

Description	INSPECTED	CONDITION	CLEAN/LUBE
OVERALL CLEANLINESS	✓	Good	
INSULATING MEMBERS	✓	Good	
MECHANICAL CONNECTIONS	✓	Good	
STRUCTURAL MEMBERS	✓	Good	
CUBICLE	✓	Good	
RACKING DEVICES	✓	Good	
SHUTTER	✓	Good	

Description	INSPECTED	CONDITION	CLEAN/LUBE
CONTACT FINGERS	✓	Good	
VACUUM BOTTLE	✓	Good	
CONTACT EROSION INDICATOR	✓	Good	
OPERATING MECHANISM	✓	Good	
CONTACT SEQUENCE	✓	Good	
GROUND CONNECTION	✓	Good	
AUXILIARY DEVICES	✓	Good	

INSULATION TEST VOLTAGE 5,000 kVDC EQUIPMENT TEMPERATURE 20 °C
 MILLIWATT LOSS TEST VOLTAGE _____ kVAC HIGH POTENTIAL TEST VOLTAGE 14000 kVAC

INSULATION RESISTANCE	POLE 1	POLE 2	POLE 3
	READING	READING	READING
POLE TO POLE (CLOSED)	3.60 T	5.11 T	4.27 T
POLE TO FRAME (CLOSED)	860 G	1.23 T	5.3 T
LINE TO FRAME (OPEN)	608 G	1.44 T	1.23 T
LOAD TO FRAME (OPEN)	653 G	1.23 T	1.41 T
LINE TO LOAD (OPEN)	3.41 T	1.99 T	3.87 T

	POLE 1	POLE 2	POLE 3
HIPOT - CLOSED kVAC	9.2	9.4	9.4
HIPOT - OPEN kVAC	9.2	9.4	9.2

CONTACT MEASUREMENTS	POLE 1	POLE 2	POLE 3	
FUSES - OHMS				
CONTACT RESISTANCE MICRO-OHMS	RDG.	22	22	21

COUNTER READING: BEG. 00553
 END 00554

COMMENTS: _____
 DEFICIENCIES: _____

EQUIPMENT USED	#	Manufacturer	Model	Serial / ID Number	Type	Calibration Date	Calibration Due
	1	FLUKE	FLUKE - 87V	38210208	MULTIMETER	1/14/2023	1/14/2024
	2	MEGGER	10 kV	102345653	INSULATION	1/20/2023	1/20/2024
	3	MEGGER	1006-603	102354950	DLRO10HD	1/20/2023	1/20/2024
	4	HVI	50kV AC HIPOT	2534	AC - HIPOT	1/8/2023	1/8/2024

TESTED BY: Matthew Falchetti / Andrew Kirk

VACUUM CIRCUIT BREAKER TEST



CUSTOMER Orange Cogen PAGE _____
 ADDRESS 1901 S. Clear Springs Rd; Bartow FL 33830 DATE 10/6/2023
 OWNER Orange Cogen; 1901 S. Clear Springs Rd; Bartow FL 33830 JOB # OCFL2310066
 SITE Orange Cogen TEST STATUS _____ Pass
 SUBSTATION Main MCC ASSET ID Station Service Trans. 116E220
 EQUIPMENT 5kV Breakers AMBIENT TEMPERATURE 77 °F HUMIDITY 65 %

MANUFACTURER Siemens SERIAL NUMBER R-99515A-1
 TYPE 5-GMI-250-1200-58 MODEL NO. AC High Voltage Circuit Breaker DATE MANUFACTURED 1994
 MAXIMUM VOLTAGE 5000 kV AMPACITY 1200 OPERATING VOLTAGE 4.76 kV
 INTERRUPTING CAPACITY 29 kA @ 1.24 kV TO _____ kV = _____ mVA

Description	INSPECTED	CONDITION	CLEAN/LUBE
OVERALL CLEANLINESS	✓	Good	
INSULATING MEMBERS	✓	Good	
MECHANICAL CONNECTIONS	✓	Good	
STRUCTURAL MEMBERS	✓	Good	
CUBICLE	✓	Good	
RACKING DEVICES	✓	Good	
SHUTTER	✓	Good	

Description	INSPECTED	CONDITION	CLEAN/LUBE
CONTACT FINGERS	✓	Good	
VACUUM BOTTLE	✓	Good	
CONTACT EROSION INDICATOR	✓	Good	
OPERATING MECHANISM	✓	Good	
CONTACT SEQUENCE	✓	Good	
GROUND CONNECTION	✓	Good	
AUXILIARY DEVICES	✓	Good	

INSULATION TEST VOLTAGE 5,000 kVDC EQUIPMENT TEMPERATURE 20 °C
 MILLIWATT LOSS TEST VOLTAGE _____ kVAC HIGH POTENTIAL TEST VOLTAGE 14000 kVAC

INSULATION RESISTANCE	POLE 1	POLE 2	POLE 3
	READING	READING	READING
POLE TO POLE (CLOSED)	1.04 T	1.13 T	1.02 T
POLE TO FRAME (CLOSED)	985 G	992 G	987 G
LINE TO FRAME (OPEN)	258 G	648 G	932 G
LOAD TO FRAME (OPEN)	411 G	518 G	451 G
LINE TO LOAD (OPEN)	589 G	1.09 T	1.09 T

	POLE 1	POLE 2	POLE 3
HIPOT - CLOSED kVAC	9.0	9.2	9.2
HIPOT - OPEN kVAC	9.2	9.4	9.2

CONTACT MEASUREMENTS	POLE 1	POLE 2	POLE 3
FUSES - OHMS			
CONTACT RESISTANCE MICRO-OHMS	RDG.	22	22
		20	

COUNTER READING: BEG. 00489
 END 00490

COMMENTS: _____
 DEFICIENCIES: _____

EQUIPMENT USED	#	Manufacturer	Model	Serial / ID Number	Type	Calibration Date	Calibration Due
	1	FLUKE	FLUKE - 87V	38210208	MULTIMETER	1/14/2023	1/14/2024
	2	MEGGER	10 kV	102345653	INSULATION	1/20/2023	1/20/2024
	3	MEGGER	1006-603	102354950	DLRO10HD	1/20/2023	1/20/2024
	4	HVI	50kV AC HIPOT	2534	AC - HIPOT	1/8/2023	1/8/2024

TESTED BY: Matthew Falchetti / Andrew Kirk

VACUUM CIRCUIT BREAKER TEST



CUSTOMER Orange Cogen PAGE _____
 ADDRESS 1901 S. Clear Springs Rd; Bartow FL 33830 DATE 10/6/2023
 OWNER Orange Cogen; 1901 S. Clear Springs Rd; Bartow FL 33830 JOB # OCFL2310066
 SITE Orange Cogen TEST STATUS _____ Pass
 SUBSTATION Main MCC ASSET ID Main Breaker - 52-1A
 EQUIPMENT 5kV Breakers AMBIENT TEMPERATURE 77 °F HUMIDITY 65 %

MANUFACTURER Siemens SERIAL NUMBER R-99515A-5
 TYPE 5-GMI-250-1200-58 MODEL NO. AC High Voltage Circuit Breaker DATE MANUFACTURED 1994
 MAXIMUM VOLTAGE 5000 kV AMPACITY 1200 OPERATING VOLTAGE 4.76 kV
 INTERRUPTING CAPACITY 29 kA @ 1.24 kV TO _____ kV = _____ mVA

Description	INSPECTED	CONDITION	CLEAN/LUBE
OVERALL CLEANLINESS	✓	Good	
INSULATING MEMBERS	✓	Good	
MECHANICAL CONNECTIONS	✓	Good	
STRUCTURAL MEMBERS	✓	Good	
CUBICLE	✓	Good	
RACKING DEVICES	✓	Good	
SHUTTER	✓	Good	

Description	INSPECTED	CONDITION	CLEAN/LUBE
CONTACT FINGERS	✓	Good	
VACUUM BOTTLE	✓	Good	
CONTACT EROSION INDICATOR	✓	Good	
OPERATING MECHANISM	✓	Good	
CONTACT SEQUENCE	✓	Good	
GROUND CONNECTION	✓	Good	
AUXILIARY DEVICES	✓	Good	

INSULATION TEST VOLTAGE 5,000 kVDC EQUIPMENT TEMPERATURE 20 °C
 MILLIWATT LOSS TEST VOLTAGE _____ kVAC HIGH POTENTIAL TEST VOLTAGE 14000 kVAC

INSULATION RESISTANCE	POLE 1	POLE 2	POLE 3
	READING	READING	READING
POLE TO POLE (CLOSED)	1.08 T	1.09 T	1.05 T
POLE TO FRAME (CLOSED)	1.07 T	1.06 T	1.03 T
LINE TO FRAME (OPEN)	258 G	648 G	932 G
LOAD TO FRAME (OPEN)	411 G	518 G	451 G
LINE TO LOAD (OPEN)	1.14 T	1.13 T	1.2 T

	POLE 1	POLE 2	POLE 3
HIPOT - CLOSED kVAC	9.0	9.0	9.0
HIPOT - OPEN kVAC	9.2	9.2	9.2

CONTACT MEASUREMENTS	POLE 1	POLE 2	POLE 3
FUSES - OHMS			
CONTACT RESISTANCE MICRO-OHMS	RDG. 28	21	22

COUNTER READING: BEG. 00604
 END 00605

COMMENTS: _____
 DEFICIENCIES: _____

EQUIPMENT USED	#	Manufacturer	Model	Serial / ID Number	Type	Calibration Date	Calibration Due
	1	FLUKE	FLUKE - 87V	38210208	MULTIMETER	12/14/2022	12/14/2023
	2	MEGGER	10 kV	102345653	INSULATION	12/20/2022	1/1/1970
	3	MEGGER	1006-603	102354950	DLRO10HD	12/20/2022	1/1/1970
	4	HVI	50kV AC HIPOT	2534	AC - HIPOT	12/8/2022	1/1/1970

TESTED BY: Chris Weedman / Andrew Kirk

VACUUM CIRCUIT BREAKER TEST



CUSTOMER Orange Cogen PAGE _____
 ADDRESS 1901 S. Clear Springs Rd; Bartow FL 33830 DATE 9/30/2023
 OWNER Orange Cogen; 1901 S. Clear Springs Rd; Bartow FL 33830 JOB # OCFL2310066
 SITE Orange Cogen TEST STATUS _____ Pass
 SUBSTATION Main MCC ASSET ID Tie Breaker T1-52
 EQUIPMENT 5kV Breakers AMBIENT TEMPERATURE 75 °F HUMIDITY 61 %

MANUFACTURER Siemens SERIAL NUMBER R-99515A-3
 TYPE 5-GMI-250-1200-58 MODEL NO. AC High Voltage Circuit Breaker DATE MANUFACTURED 1994
 MAXIMUM VOLTAGE 5000 kV AMPACITY 1200 OPERATING VOLTAGE 4.76 kV
 INTERRUPTING CAPACITY 29 kA @ 1.24 kV TO _____ kV = _____ mVA

Description	INSPECTED	CONDITION	CLEAN/LUBE
OVERALL CLEANLINESS	✓	Good	
INSULATING MEMBERS	✓	Good	
MECHANICAL CONNECTIONS	✓	Good	
STRUCTURAL MEMBERS	✓	Good	
CUBICLE	✓	Good	
RACKING DEVICES	✓	Good	
SHUTTER	✓	Good	

Description	INSPECTED	CONDITION	CLEAN/LUBE
CONTACT FINGERS	✓	Good	
VACUUM BOTTLE	✓	Good	
CONTACT EROSION INDICATOR	✓	Good	
OPERATING MECHANISM	✓	Good	
CONTACT SEQUENCE	✓	Good	
GROUND CONNECTION	✓	Good	
AUXILIARY DEVICES	✓	Good	

INSULATION TEST VOLTAGE 5,000 kVDC EQUIPMENT TEMPERATURE 20 °C
 MILLIWATT LOSS TEST VOLTAGE _____ kVAC HIGH POTENTIAL TEST VOLTAGE 14000 kVAC

INSULATION RESISTANCE	POLE 1	POLE 2	POLE 3
	READING	READING	READING
POLE TO POLE (CLOSED)	3.17 T	6.82 T	3.95 T
POLE TO FRAME (CLOSED)	1.08 T	1.45 T	1.76 G
LINE TO FRAME (OPEN)	2.16 T	2.39 T	711 G
LOAD TO FRAME (OPEN)	1.96 T	2.12 T	1.97 T
LINE TO LOAD (OPEN)	1.33 T	1.73 T	1.68 T

	POLE 1	POLE 2	POLE 3
HIPOT - CLOSED kVAC	9.4	9.4	9.2
HIPOT - OPEN kVAC	9.3	9.2	9.2

CONTACT MEASUREMENTS	POLE 1	POLE 2	POLE 3
FUSES - OHMS			
CONTACT RESISTANCE MICRO-OHMS	RDG. 21	18	23

COUNTER READING: BEG. 00654
 END 00655

COMMENTS: _____
 DEFICIENCIES: _____

EQUIPMENT USED	#	Manufacturer	Model	Serial / ID Number	Type	Calibration Date	Calibration Due
	1	FLUKE	FLUKE - 87V	38210208	MULTIMETER	12/14/2022	12/14/2023
	2	MEGGER	10 kV	102345653	INSULATION F	12/20/2022	1/1/1970
	3	MEGGER	1006-603	102354950	DLRO10HD	12/20/2022	1/1/1970
	4	HVI	50kV AC HIPOT	2534	AC - HIPOT	12/8/2022	1/1/1970

TESTED BY: Chris Weedman / Andrew Kirk

VACUUM CIRCUIT BREAKER TEST



CUSTOMER Orange Cogen PAGE _____
 ADDRESS 1901 S. Clear Springs Rd; Bartow FL 33830 DATE 10/6/2023
 OWNER Orange Cogen; 1901 S. Clear Springs Rd; Bartow FL 33830 JOB # OCFL2310066
 SITE Orange Cogen TEST STATUS _____ Pass
 SUBSTATION Switch-Yard ASSET ID 52GT1 Breaker
 EQUIPMENT 15kV Breakers AMBIENT TEMPERATURE 80 °F HUMIDITY 94 %

MANUFACTURER Siemens SERIAL NUMBER 28995-00-001
 TYPE 15-GMI-1000-3000-77 MODEL NO. AC High Voltage Circuit Breaker DATE MANUFACTURED 2006
 MAXIMUM VOLTAGE 15000 kV AMPACITY 3000 OPERATING VOLTAGE 13800 kV
 INTERRUPTING CAPACITY 48 kA @ _____ kV TO _____ kV = _____ mVA

Description	INSPECTED	CONDITION	CLEAN/LUBE
OVERALL CLEANLINESS	✓	Good	
INSULATING MEMBERS	✓	Good	
MECHANICAL CONNECTIONS	✓	Good	
STRUCTURAL MEMBERS	✓	Good	
CUBICLE	✓	Good	
RACKING DEVICES	✓	Good	
SHUTTER	✓	Good	

Description	INSPECTED	CONDITION	CLEAN/LUBE
CONTACT FINGERS	✓	Good	
VACUUM BOTTLE	✓	Good	
CONTACT EROSION INDICATOR	✓	Good	
OPERATING MECHANISM	✓	Good	
CONTACT SEQUENCE	✓	Good	
GROUND CONNECTION	✓	Good	
AUXILIARY DEVICES	✓	Good	

INSULATION TEST VOLTAGE 10,000 kVDC EQUIPMENT TEMPERATURE 20 °C
 MILLIWATT LOSS TEST VOLTAGE N/A kVAC HIGH POTENTIAL TEST VOLTAGE 27000 kVAC

INSULATION RESISTANCE	POLE 1	POLE 2	POLE 3
	READING	READING	READING
POLE TO POLE (CLOSED)	9.96 G	18.1 G	13.7 G
POLE TO FRAME (CLOSED)	10.2 G	6.17 G	4.01 G
LINE TO FRAME (OPEN)	8.95 G	27.0 G	20.6 G
LOAD TO FRAME (OPEN)	3.48 G	6.64 G	10.9 G
LINE TO LOAD (OPEN)	3.97 G	23.1 G	13.02 G

	POLE 1	POLE 2	POLE 3
HIPOT - CLOSED kVAC	9.4	9.2	9.4
HIPOT - OPEN kVAC	9.6	9.4	9.6

CONTACT MEASUREMENTS	POLE 1	POLE 2	POLE 3
FUSES - OHMS			
CONTACT RESISTANCE MICRO-OHMS	RDG. 39	31	30

COUNTER READING: BEG. 02585
 END 02586

COMMENTS:
 DEFICIENCIES: Wheels on breaker all broke - Replaced with ones from Spare Breaker

EQUIPMENT USED	#	Manufacturer	Model	Serial / ID Number	Type	Calibration Date	Calibration Due
	1	MEGGER	10 kV	102345653	INSULATION	12/20/2022	1/1/1970
	2	MEGGER	1006-603	102305978	DLRO10HD	12/14/2022	12/14/2023
	3	HVI	50kV AC HIPOT	2534	AC - HIPOT	12/8/2022	1/1/1970

TESTED BY: Matthew Falchetti / Andrew Kirk

VACUUM CIRCUIT BREAKER TEST



CUSTOMER Orange Cogen PAGE _____
 ADDRESS 1901 S. Clear Springs Rd; Bartow FL 33830 DATE 9/28/2023
 OWNER Orange Cogen; 1901 S. Clear Springs Rd; Bartow FL 33830 JOB # OCFL2310066
 SITE Orange Cogen TEST STATUS _____ Pass
 SUBSTATION Switch-Yard ASSET ID 52STG Breaker
 EQUIPMENT 15kV Breakers AMBIENT TEMPERATURE 75 °F HUMIDITY 100 %

MANUFACTURER Siemens SERIAL NUMBER R-99512B-1
 TYPE 15-GMI-1000-2000-77 MODEL NO. AC High Voltage Circuit Breaker DATE MANUFACTURED 1994
 MAXIMUM VOLTAGE 15000 kV AMPACITY 2000 OPERATING VOLTAGE 13800 kV
 INTERRUPTING CAPACITY 37 kA @ _____ kV TO _____ kV = _____ mVA

Description	INSPECTED	CONDITION	CLEAN/LUBE
OVERALL CLEANLINESS	<input checked="" type="checkbox"/>	Good	
INSULATING MEMBERS	<input checked="" type="checkbox"/>	Good	
MECHANICAL CONNECTIONS	<input checked="" type="checkbox"/>	Good	
STRUCTURAL MEMBERS	<input checked="" type="checkbox"/>	Good	
CUBICLE	<input checked="" type="checkbox"/>	Good	
RACKING DEVICES	<input checked="" type="checkbox"/>	Good	
SHUTTER	<input checked="" type="checkbox"/>	Good	

Description	INSPECTED	CONDITION	CLEAN/LUBE
CONTACT FINGERS	<input checked="" type="checkbox"/>	Good	
VACUUM BOTTLE	<input checked="" type="checkbox"/>	Good	
CONTACT EROSION INDICATOR	<input checked="" type="checkbox"/>	Good	
OPERATING MECHANISM	<input checked="" type="checkbox"/>	Good	
CONTACT SEQUENCE	<input checked="" type="checkbox"/>	Good	
GROUND CONNECTION	<input checked="" type="checkbox"/>	Good	
AUXILIARY DEVICES	<input checked="" type="checkbox"/>	Good	

INSULATION TEST VOLTAGE 10,000 kVDC EQUIPMENT TEMPERATURE 20 °C
 MILLIWATT LOSS TEST VOLTAGE N/A kVAC HIGH POTENTIAL TEST VOLTAGE 27000 kVAC

INSULATION RESISTANCE	POLE 1	POLE 2	POLE 3
	READING	READING	READING
POLE TO POLE (CLOSED)	1.65 G	2.64 G	3.04 G
POLE TO FRAME (CLOSED)	2.20 G	3.86 G	2.59 G
LINE TO FRAME (OPEN)	3.41 G	12.54 G	5.37 G
LOAD TO FRAME (OPEN)	13.95 G	8.4 G	3.26 G
LINE TO LOAD (OPEN)	4.82 G	11.44 G	8.65 G

	POLE 1	POLE 2	POLE 3
HIPOT - CLOSED kVAC	9.8	9.6	9.6
HIPOT - OPEN kVAC	9.4	9.6	9.4

CONTACT MEASUREMENTS	POLE 1	POLE 2	POLE 3	
FUSES - OHMS				
CONTACT RESISTANCE MICRO-OHMS	RDG.	15	14	16

COUNTER READING: BEG. 01058
 END 01059

COMMENTS:
 DEFICIENCIES: Open / Close interlock bolt was missing and held the lever down - Fixed

EQUIPMENT USED	#	Manufacturer	Model	Serial / ID Number	Type	Calibration Date	Calibration Due
	1	MEGGER	10 kV	102345653	INSULATION	12/20/2022	1/1/1970
	2	MEGGER	1006-603	102305978	DLRO10HD	12/14/2022	12/14/2023
	3	HVI	50kV AC HIPOT	2534	AC - HIPOT	12/8/2022	1/1/1970

TESTED BY: Matthew Falchetti / Andrew Kirk

VACUUM CIRCUIT BREAKER TEST



CUSTOMER Orange Cogen PAGE _____
 ADDRESS 1901 S. Clear Springs Rd; Bartow FL 33830 DATE 9/28/2023
 OWNER Orange Cogen; 1901 S. Clear Springs Rd; Bartow FL 33830 JOB # OCFL2310066
 SITE Orange Cogen TEST STATUS _____ Pass
 SUBSTATION Switch-Yard ASSET ID 52GT2 Breaker
 EQUIPMENT 15kV Breakers AMBIENT TEMPERATURE 75 °F HUMIDITY 100 %

MANUFACTURER Siemens SERIAL NUMBER R-3006127035-100-001
 TYPE 15-GMI-1000-3000-77 MODEL NO. AC High Voltage Circuit Breaker DATE MANUFACTURED 2016
 MAXIMUM VOLTAGE 15000 kV AMPACITY 3000 OPERATING VOLTAGE 13800 kV
 INTERRUPTING CAPACITY 48 kA @ _____ kV TO _____ kV = _____ mVA

Description	INSPECTED	CONDITION	CLEAN/LUBE
OVERALL CLEANLINESS	✓	Good	
INSULATING MEMBERS	✓	Good	
MECHANICAL CONNECTIONS	✓	Good	
STRUCTURAL MEMBERS	✓	Good	
CUBICLE	✓	Good	
RACKING DEVICES	✓	Good	
SHUTTER	✓	Good	

Description	INSPECTED	CONDITION	CLEAN/LUBE
CONTACT FINGERS	✓	Good	
VACUUM BOTTLE	✓	Good	
CONTACT EROSION INDICATOR	✓	Good	
OPERATING MECHANISM	✓	Good	
CONTACT SEQUENCE	✓	Good	
GROUND CONNECTION	✓	Good	
AUXILIARY DEVICES	✓	Good	

INSULATION TEST VOLTAGE 10,000 kVDC EQUIPMENT TEMPERATURE 20 °C
 MILLIWATT LOSS TEST VOLTAGE N/A kVAC HIGH POTENTIAL TEST VOLTAGE 27000 kVAC

INSULATION RESISTANCE	POLE 1	POLE 2	POLE 3
	READING	READING	READING
POLE TO POLE (CLOSED)	107.3 G	80.5 G	49.4 G
POLE TO FRAME (CLOSED)	48.2 G	77.5 G	56.6 G
LINE TO FRAME (OPEN)	11.99 G	22.9 G	28.1 G
LOAD TO FRAME (OPEN)	31.7 G	42.4 G	7.54 G
LINE TO LOAD (OPEN)	17.74 G	10.66 G	12.77 G

	POLE 1	POLE 2	POLE 3
HIPOT - CLOSED kVAC	9.4	9.4	9.6
HIPOT - OPEN kVAC	9.6	9.4	9.2

CONTACT MEASUREMENTS	POLE 1	POLE 2	POLE 3
FUSES - OHMS			
CONTACT RESISTANCE MICRO-OHMS	RDG. 24	20	20

COUNTER READING: BEG. 01061
 END 01062

COMMENTS: _____
 DEFICIENCIES: _____

EQUIPMENT USED	#	Manufacturer	Model	Serial / ID Number	Type	Calibration Date	Calibration Due
	1	MEGGER	10 kV	102345653	INSULATION	12/20/2022	1/1/1970
	2	MEGGER	1006-603	102305978	DLRO10HD	12/14/2022	12/14/2023
	3	HVI	50kV AC HIPOT	2534	AC - HIPOT	12/8/2022	1/1/1970

TESTED BY: Matthew Falchetti / Andrew Kirk

CT TEST REPORT



CUSTOMER Orange Cogen PAGE _____
 ADDRESS 1901 S. Clear Springs Rd; Bartow FL 33830 DATE 9/28/2023
 USER Orange Cogen; 1901 S. Clear Springs Rd; Bartow FL 33830 JOB # OCFL2310066
 SITE Orange Cogen TEST STATUS _____ Pass
 SUBSTATION Switch-Yard ASSET ID _____ 52-L2-X1
 EQUIPMENT 52-L2 SF-6 - CT's AMBIENT TEMPERATURE 82 °F HUMIDITY 70 %

CT: CT1		NAMEPLATE DATA				
MANUFACTURER	Siemens	SERIAL NO.			IN SERVICE TAP	
ASSET ID		ACCURACY CLASS	C800	Protection	SATURATION STD	ANSI 45
PHASE		BURDEN	B-8		VA	200

Tap	Ratio						Knee		Phase Dev.	Polarity
	Nameplate	Measured	% Error	Test V (V)	Test I (A)	Prim V (V)	Volt.(V)	Cur.(A)		
X1-X2	200:5	200.009:5	0.004	9.9829	0.1818	0.2496			359°58'	Correct
X1-X3	800:5	800.14:5	0.018	39.936	0.0455	0.2496			359°58'	Correct
X1-X4	1600:5	1600.07:5	0.005	79.863	0.0227	0.2496			359°58'	Correct
X1-X5	2000:5	1999.38:5	-0.031	99.793	0.0182	0.2496			359°58'	Correct
X2-X3	600:5	600.132:5	0.022	29.954	0.0606	0.2496			359°58'	Correct
X2-X4	1400:5	1400.07:5	0.005	69.880	0.0260	0.2496			359°58'	Correct
X2-X5	1800:5	1799.37:5	-0.035	89.810	0.0202	0.2496			359°58'	Correct
X3-X4	800:5	799.934:5	-0.008	39.926	0.0455	0.2496			359°58'	Correct
X3-X5	1200:5	1199.24:5	-0.063	59.856	0.0303	0.2496			359°58'	Correct
X4-X5	400:5	399.308:5	-0.173	19.930	0.0911	0.2496			359°58'	Correct

COMMENTS: _____
 DEFICIENCIES: _____

EQUIPMENT USE#	#	Manufacturer	Model	Serial / ID Number	Type	Calibration Date	Calibration Due
	1	MEGGER	MRCT	202211050016	CT/RELAY T	1/14/2023	1/14/2024

TEST EQUIPMENT USED: Megger MRCT 202211050016 TESTED BY: Matthew Falchetti

CT TEST REPORT



CUSTOMER Orange Cogen PAGE _____
 ADDRESS 1901 S. Clear Springs Rd; Bartow FL 33830 DATE 9/28/2023
 USER Orange Cogen; 1901 S. Clear Springs Rd; Bartow FL 33830 JOB # OCFL2310066
 SITE Orange Cogen TEST STATUS _____ Pass
 SUBSTATION Switch-Yard ASSET ID _____ 52-L2 -X3
 EQUIPMENT 52-L2 SF-6 - CT's AMBIENT TEMPERATURE 82 °F HUMIDITY 70 %

CT: CT1		NAMEPLATE DATA			
MANUFACTURER	Siemens	SERIAL NO.			
ASSET ID	52-T2-SF-6 Breaker	ACCURACY CLASS	C800	Protection	SATURATION STD
PHASE		BURDEN	B-8	VA	ANSI 45
					200

Tap	Ratio						Knee		Phase Dev.	Polarity
	Nameplate	Measured	% Error	Test V (V)	Test I (A)	Prim V (V)	Volt.(V)	Cur.(A)		
X1-X2	200:5	200.002:5	0.001	9.9846	0.1342	0.2496			359°58'	Correct
X1-X3	800:5	800.107:5	0.013	39.943	0.0335	0.2496			359°58'	Correct
X1-X4	1600:5	1600.02:5	0.001	79.877	0.0168	0.2496			359°58'	Correct
X1-X5	2000:5	1999.29:5	-0.035	99.809	0.0134	0.2496			359°58'	Correct
X2-X3	600:5	600.105:5	0.018	29.958	0.0447	0.2496			359°58'	Correct
X2-X4	1400:5	1400.02:5	0.001	69.892	0.0192	0.2496			359°58'	Correct
X2-X5	1800:5	1799.29:5	-0.039	89.825	0.0149	0.2496			359°58'	Correct
X3-X4	800:5	799.916:5	-0.011	39.933	0.0335	0.2496			359°58'	Correct
X4-X5	400:5	399.27:5	-0.183	19.932	0.0672	0.2496			359°58'	Correct

COMMENTS: _____
 DEFICIENCIES: _____

EQUIPMENT USE#	#	Manufacturer	Model	Serial / ID Number	Type	Calibration Date	Calibration Due
	1	MEGGER	MRCT	202211050016	CT/RELAY T	1/14/2023	1/14/2024

TEST EQUIPMENT USED: Megger MRCT 202211050016 TESTED BY: Matthew Falchetti

CT TEST REPORT



CUSTOMER Orange Cogen PAGE _____
 ADDRESS 1901 S. Clear Springs Rd; Bartow FL 33830 DATE 9/28/2023
 USER Orange Cogen; 1901 S. Clear Springs Rd; Bartow FL 33830 JOB # OCFL2310066
 SITE Orange Cogen TEST STATUS _____ Pass
 SUBSTATION Switch-Yard ASSET ID _____ 52-L2-X5
 EQUIPMENT 52-L2 SF-6 - CT's AMBIENT TEMPERATURE 82 °F HUMIDITY 70 %

CT: CT1		NAMEPLATE DATA			
MANUFACTURER	Siemens	SERIAL NO.		IN SERVICE TAP	
ASSET ID		ACCURACY CLASS	C800 Protection	SATURATION STD	ANSI 45
PHASE		BURDEN	B-8	VA	200

Tap	Ratio						Knee		Phase Dev.	Polarity
	Nameplate	Measured	% Error	Test V (V)	Test I (A)	Prim V (V)	Volt.(V)	Cur.(A)		
X1-X2	200:5	200.009:5	0.004	9.9829	0.1818	0.2496			359°58'	Correct
X1-X3	800:5	800.14:5	0.018	39.936	0.0455	0.2496			359°58'	Correct
X1-X4	1600:5	1600.07:5	0.005	79.863	0.0227	0.2496			359°58'	Correct
X1-X5	2000:5	1999.38:5	-0.031	99.793	0.0182	0.2496			359°58'	Correct
X2-X3	600:5	600.132:5	0.022	29.954	0.0606	0.2496			359°58'	Correct
X2-X4	1400:5	1400.07:5	0.005	69.880	0.0260	0.2496			359°58'	Correct
X2-X5	1800:5	1799.37:5	-0.035	89.810	0.0202	0.2496			359°58'	Correct
X3-X4	800:5	799.934:5	-0.008	39.926	0.0455	0.2496			359°58'	Correct
X3-X5	1200:5	1199.24:5	-0.063	59.856	0.0303	0.2496			359°58'	Correct
X4-X5	400:5	399.308:5	-0.173	19.930	0.0911	0.2496			359°58'	Correct

COMMENTS: _____
 DEFICIENCIES: _____

EQUIPMENT USE	#	Manufacturer	Model	Serial / ID Number	Type	Calibration Date	Calibration Due
	1	MEGGER	MRCT	202211050016	CT/RELAY T	1/14/2023	1/14/2024

TEST EQUIPMENT USED: Megger MRCT 202211050016 TESTED BY: Matthew Falchetti

CT TEST REPORT



CUSTOMER Orange Cogen PAGE _____
 ADDRESS 1901 S. Clear Springs Rd; Bartow FL 33830 DATE 10/5/2023
 USER Orange Cogen; 1901 S. Clear Springs Rd; Bartow FL 33830 JOB # OCFL2310066
 SITE Orange Cogen TEST STATUS _____ Pass
 SUBSTATION T1 Side ASSET ID _____ 52-L1-X1
 EQUIPMENT 52-L1 SF-6 - CT's AMBIENT TEMPERATURE 80 °F HUMIDITY 65 %

CT: CT1		NAMEPLATE DATA				
MANUFACTURER	Siemens	SERIAL NO.			IN SERVICE TAP	
ASSET ID		ACCURACY CLASS	C800	Protection	SATURATION STD	ANSI 45
PHASE		BURDEN	B-8		VA	200

Tap	Ratio						Knee		Phase Dev.	Polarity
	Nameplate	Measured	% Error	Test V (V)	Test I (A)	Prim V (V)	Volt.(V)	Cur.(A)		
X1-X2	200:5	200.031:5	0.015	9.9848	0.1754	0.2496			359°58'	Correct
X1-X3	800:5	800.136:5	0.017	39.939	0.0438	0.2496			359°58'	Correct
X1-X4	1600:5	1600.2:5	0.013	79.876	0.0219	0.2496			359°58'	Correct
X1-X5	2000:5	1999.65:5	-0.017	99.815	0.0175	0.2496			359°58'	Correct
X2-X3	600:5	600.105:5	0.017	29.955	0.0585	0.2496			359°58'	Correct
X2-X4	1400:5	1400.17:5	0.012	69.891	0.0251	0.2496			359°58'	Correct
X2-X5	1800:5	1799.62:5	-0.021	89.830	0.0195	0.2496			359°58'	Correct
X3-X4	800:5	800.065:5	0.008	39.936	0.0438	0.2496			359°58'	Correct
X3-X5	1200:5	1199.51:5	-0.041	59.875	0.0292	0.2496			359°58'	Correct
X4-X5	400:5	399.449:5	-0.138	19.939	0.0878	0.2496			359°58'	Correct

COMMENTS: _____
 DEFICIENCIES: _____

EQUIPMENT USE#	#	Manufacturer	Model	Serial / ID Number	Type	Calibration Date	Calibration Due
	1	MEGGER	MRCT	202211050016	CT/RELAY T	1/14/2023	1/14/2024

TEST EQUIPMENT USED: Megger MRCT 202211050016 TESTED BY: Matthew Falchetti

CT TEST REPORT



CUSTOMER Orange Cogen PAGE _____
 ADDRESS 1901 S. Clear Springs Rd; Bartow FL 33830 DATE 10/5/2023
 USER Orange Cogen; 1901 S. Clear Springs Rd; Bartow FL 33830 JOB # OCFL2310066
 SITE Orange Cogen TEST STATUS _____ Pass
 SUBSTATION T1 Side ASSET ID _____ 52-L1-X5
 EQUIPMENT 52-L1 SF-6 - CT's AMBIENT TEMPERATURE 80 °F HUMIDITY 65 %

CT: CT1		NAMEPLATE DATA					
MANUFACTURER	Siemens	SERIAL NO.			IN SERVICE TAP		
ASSET ID		ACCURACY CLASS	C800	Protection	SATURATION STD	ANSI 45	
PHASE		BURDEN	B-8		VA	200	
Test Frequency	16.67Hz					Buried CT in Delta Connection	<input type="checkbox"/>

Tap	Ratio						Knee		Phase Dev.	Polarity
	Nameplate	Measured	% Error	Test V (V)	Test I (A)	Prim V (V)	Volt.(V)	Cur.(A)		
X1-X2	200:5	200.026:5	0.013	9.9959	0.2092	0.2499			359°59'	Correct
X1-X3	800:5	800.123:5	0.015	39.984	0.0523	0.2499			359°59'	Correct
X1-X4	1600:5	1600.19:5	0.012	79.966	0.0261	0.2499			359°59'	Correct
X1-X5	2000:5	1999.74:5	-0.013	99.933	0.0209	0.2499			359°59'	Correct
X2-X3	600:5	600.097:5	0.016	29.988	0.0697	0.2499			359°59'	Correct
X2-X4	1400:5	1400.16:5	0.012	69.970	0.0299	0.2499			359°59'	Correct
X2-X5	1800:5	1799.71:5	-0.016	89.937	0.0232	0.2499			359°59'	Correct
X3-X4	800:5	800.065:5	0.008	39.981	0.0523	0.2499			359°59'	Correct
X3-X5	1200:5	1199.61:5	-0.032	59.948	0.0349	0.2499			359°59'	Correct
X4-X5	400:5	399.55:5	-0.113	19.966	0.1047	0.2499			359°59'	Correct

COMMENTS: _____
 DEFICIENCIES: _____

EQUIPMENT USED	#	Manufacturer	Model	Serial / ID Number	Type	Calibration Date	Calibration Due
	1	MEGGER	MRCT	202211050016	CT/RELAY T	1/14/2023	1/14/2024

TEST EQUIPMENT USED: Megger MRCT 202211050016 TESTED BY: Matthew Falchetti

CT TEST REPORT



CUSTOMER Orange Cogen PAGE _____
 ADDRESS 1901 S. Clear Springs Rd; Bartow FL 33830 DATE 10/5/2023
 USER Orange Cogen; 1901 S. Clear Springs Rd; Bartow FL 33830 JOB # OCFL2310066
 SITE Orange Cogen TEST STATUS _____ Pass
 SUBSTATION T1 Side ASSET ID _____ 52-L1-X3
 EQUIPMENT 52-L1 SF-6 - CT's AMBIENT TEMPERATURE 80 °F HUMIDITY 65 %

CT: CT1		NAMEPLATE DATA					
MANUFACTURER	Siemens	SERIAL NO.			IN SERVICE TAP		
ASSET ID		ACCURACY CLASS	C800	Protection	SATURATION STD	ANSI 45	
PHASE		BURDEN	B-8		VA	200	
Test Frequency	16.67Hz					Buried CT in Delta Connection	<input type="checkbox"/>

Tap	Ratio						Knee		Phase Dev.	Polarity
	Nameplate	Measured	% Error	Test V (V)	Test I (A)	Prim V (V)	Volt.(V)	Cur.(A)		
X1-X2	200:5	200.029:5	0.014	9.9988	0.2083	0.2499			359°59'	Correct
X1-X3	800:5	800.143:5	0.018	39.996	0.0521	0.2499			359°59'	Correct
X1-X4	1600:5	1600.3:5	0.019	79.993	0.0260	0.2499			359°59'	Correct
X1-X5	2000:5	1999.83:5	-0.008	99.964	0.0208	0.2499			359°59'	Correct
X2-X3	600:5	600.114:5	0.019	29.997	0.0694	0.2499			359°59'	Correct
X2-X4	1400:5	1400.28:5	0.020	69.995	0.0298	0.2499			359°59'	Correct
X2-X5	1800:5	1799.8:5	-0.011	89.966	0.0232	0.2499			359°59'	Correct
X3-X4	800:5	800.161:5	0.020	39.997	0.0521	0.2499			359°59'	Correct
X3-X5	1200:5	1199.69:5	-0.026	59.968	0.0347	0.2499			359°59'	Correct
X4-X5	400:5	399.53:5	-0.117	19.971	0.1043	0.2499			359°59'	Correct

COMMENTS: _____
 DEFICIENCIES: _____

EQUIPMENT USE#	#	Manufacturer	Model	Serial / ID Number	Type	Calibration Date	Calibration Due
	1	MEGGER	MRCT	202211050016	CT/RELAY T	1/14/2023	1/14/2024

TEST EQUIPMENT USED: Megger MRCT 202211050016 TESTED BY: Matthew Falchetti

T2 - GSU Transformer



Client	Orange Cogen	OCFL2310066 - T2 - GSU	
Execution date	9/29/2023	Reason of the job	Post fault
Tested by	Matthew Falchetti	Location	Orange Cogen
Approved by		Asset	Transformer
Report ID	2	Asset type	Three-winding
Report issue date	10/13/2023 8:43:21 AM	Asset serial number	LNL9182
Work order		Manufacturer	ABB

Summary

Performed tests	Assessment
Overall PF & CAP	Pass
Bushing H PF & CAP - C1	Pass
Bushing H PF & CAP - C2	Pass
Bushing H – Energized Collar	Pass
Bushing X – Energized Collar	Pass
Bushing Y – Energized Collar	Pass
Exciting Current	Pass
Surge Arrester Watt Losses H	Pass
TTR H-X	Pass
TTR H-Y	Pass
DC Winding Resistance H	Pass
DC Winding Resistance X	Pass
DC Winding Resistance Y	Pass
Insulation Resistance	Pass

Overall Assessment	No Faults
--------------------	-----------

Tested by:

Andrew Kirk

Approved by:

Matthew Falchetti

Location & company information			
Location		Company	
Name	Orange Cogen	Company	HVA – P&C / Field Services
Region		Department	South
Division	South	Address	
Area		City	Lakeland
Plant	Orange Cogen	State/Province	Florida
Address	1901 S. Clear Springs Rd	Postal code	33811
City	Bartow	Country	United States
State/Province	Florida	Phone No.	
Postal code	33830	Fax No.	
Country	United States	E-mail	

Geo coordinates	
-----------------	--

Contact person	
Name	
Phone No. 1	
Phone No. 2	
Fax No.	
E-mail	

Comment

Transformer nameplate data			
Serial number	LNL9182	Apparatus ID	T2 - GSU
Manufacturer	ABB	Feeder	
Manufacturing year	1994	No. phases	3
Manufacturer type	SL	Vector group	YNd1d1

Comment

Voltage ratings			
Winding	Voltage L-L	Voltage L-N	Insul. level L-L
H	70.690 kV	40.813 kV	350 kV
X	13.800 kV	kV	110 kV
Y	13.800 kV	kV	110 kV

Power ratings		
Rated power	Cooling class	Temp. rise wind.
33.000 MVA	OA	

Current ratings at rated power			
Winding			
H	X	Y	Rated power
927.000 A	2062.000 A	2687.000 A	33.000 MVA

Short-circuit rating		
Max. short-circuit current	kA	s

Impedances

Ref. temp.	75 °C
------------	-------

Leakage reactance H - X

Zk[%]	Base power	Base voltage	Load losses Pk	OLTC position	DETC position
%	MVA	kV	W		

Leakage reactance H - Y

Zk[%]	Base power	Base voltage	Load losses Pk	OLTC position	DETC position
%	MVA	kV	W		

Leakage reactance X - Y

Zk[%]	Base power	Base voltage	Load losses Pk	OLTC position	DETC position
%	MVA	kV	W		

Zero sequence impedance

Base power	33.00 MVA
Base voltage	72.500 kV
Description	Z0[%]
Primary	13.07 %

Others

Category	Generation
Status	In operation
Tank type	Nitrogen blanketed
Insulation medium	Mineral oil
Fluid insulation volume	9998 gals
Fluid insulation weight	lbs
Total weight	288115 lbs

Bushings nameplate data

Pos.	Serial No.	Manufact.	Manufacturer type	Man. year	Voltage L-ground	Max. system voltage	Rated current
H1	3785220394	ABB	O Plus C	1994	44.0 kV	69.0 kV	400.0 A
H2	3785220294	ABB	O Plus C	1994	44.0 kV	69.0 kV	400.0 A
H3	3785220194	ABB	O Plus C	1994	44.0 kV	69.0 kV	400.0 A
H0	2785200194	ABB		1994	15.0 kV	15.0 kV	1200.0 A
X1	8C01085406	ABB		1998	10.0 kV	15.0 kV	3300.0 A
X2	8C01085405	ABB		1998	10.0 kV	15.0 kV	3300.0 A
X3	8C01085401	ABB		1998	10.0 kV	15.0 kV	3300.0 A
Y1	8C01085402	ABB		1998	10.0 kV	15.0 kV	3300.0 A
Y2	8C01085404	ABB		1998	10.0 kV	15.0 kV	3300.0 A
Y3	8C01085403	ABB		1998	10.0 kV	15.0 kV	3300.0 A

Pos.	Insul. level LL	Cap. (C1)	PF (C1)	Cap. (C2)	PF (C2)	Insulation type	Tap type
H1	350 kV	266.00 pF	0.250 %	pF	%	Oil-impregnated paper	With potential tap
H2	350 kV	266.00 pF	0.230 %	pF	%	Oil-impregnated paper	With potential tap
H3	350 kV	272.00 pF	0.230 %	pF	%	Oil-impregnated paper	With potential tap
H0	110 kV	pF	%	pF	%	Oil-impregnated paper	Without tap
X1	110 kV	pF	%	pF	%	Porcelain dry type	Without tap
X2	110 kV	pF	%	pF	%	Porcelain dry type	Without tap
X3	110 kV	pF	%	pF	%	Porcelain dry type	Without tap
Y1	110 kV	pF	%	pF	%	Porcelain dry type	Without tap

Pos.	Insul. level LL	Cap. (C1)	PF (C1)	Cap. (C2)	PF (C2)	Insulation type	Tap type
Y2	110 kV	pF	%	pF	%	Porcelain dry type	Without tap
Y3	110 kV	pF	%	pF	%	Porcelain dry type	Without tap

Tap Changers nameplate data

DETC

Serial number	
Manufacturer	ABB
Manufacturer type	Manual
Winding	H
Tap scheme	1...N
No. of taps	5

Tap	Voltage
1	76125.0 V
2	74310.0 V
3	72500.0 V
4	70690.0 V
5	68875.0 V

Surge Arrester nameplate data

Surge arrester H1

Serial number	Manufacturer	Manufacturing year	Overall catalog no	Units in stack
668	CERAN	1994		1

Position	Serial No.	Voltage L-L	Voltage L-N	MCOV rating	Unit ID
1		kV	kV	kV	

Surge arrester H2

Serial number	Manufacturer	Manufacturing year	Overall catalog no	Units in stack
592	CERAN	1994		1

Position	Serial No.	Voltage L-L	Voltage L-N	MCOV rating	Unit ID
1		kV	kV	kV	

Surge arrester H3

Serial number	Manufacturer	Manufacturing year	Overall catalog no	Units in stack
588	CERAN	1994		1

Position	Serial No.	Voltage L-L	Voltage L-N	MCOV rating	Unit ID
1		kV	kV	kV	

Test set information

Model	Serial number	Calibration date
TESTRANO 600	EN907R	2023-02-20
CP TD12	EN043U	2023-02-27

Global test conditions

Weather	Partly cloudy	Humidity	100 %
---------	---------------	----------	-------

Overall PF & CAP

Ambient temperature	24 °C	Weather	Partly cloudy
Top oil temperature	30 °C	Humidity	100 %

Comments

--

Standard test**Block 1: injection at H**

Corr. temperature	30 °C
Corr. factor	0.8

No.	Meas.	Test mode	Freq.	V out	I out	Watt losses	PF meas	PF corr	Cap. meas	Assessment
1	ICH+ICHL	GSTg-B	60.00 Hz	10.00 kV	29.86 mA	950.54 mW	0.3184 %	0.2547 %	7918.1 pF	Pass
2	ICH	GSTg-A+B	60.00 Hz	10.00 kV	18.09 mA	717.34 mW	0.3966 %	0.3172 %	4795.7 pF	Pass
3	ICHL	UST-A	60.00 Hz	10.00 kV	11.77 mA	189.98 mW	0.1614 %	0.1291 %	3122.3 pF	Pass

Block 2: injection at X

Corr. temperature	30 °C
Corr. factor	0.8

No.	Meas.	Test mode	Freq.	V out	I out	Watt losses	PF meas	PF corr	Cap. meas	Assessment
4	ICL+ICLT	GSTg-A	60.00 Hz	7.00 kV	23.98 mA	722.84 mW	0.4307 %	0.3445 %	9083.9 pF	Pass
5	ICL	GSTg-A+B	60.00 Hz	7.00 kV	22.60 mA	664.07 mW	0.4197 %	0.3358 %	8563.0 pF	Pass
6	ICLT	UST-B	60.00 Hz	7.00 kV	1.37 mA	55.18 mW	0.5734 %	0.4588 %	520.9 pF	Pass

Block 3: injection at Y

Corr. temperature	30 °C
Corr. factor	0.8

No.	Meas.	Test mode	Freq.	V out	I out	Watt losses	PF meas	PF corr	Cap. meas	Assessment
7	ICT+ICTH	GSTg-A	60.00 Hz	7.00 kV	28.85 mA	1003.66 mW	0.4969 %	0.3975 %	10931.1 pF	Pass
8	ICT	GSTg-A+B	60.00 Hz	7.00 kV	20.70 mA	951.69 mW	0.6567 %	0.5253 %	7843.1 pF	Inv.
9	ICTH	UST-B	60.00 Hz	7.00 kV	8.15 mA	94.41 mW	0.1654 %	0.1323 %	3090.0 pF	Pass

Bushing H PF & CAP - C1

Ambient temperature	24 °C	Weather	Partly cloudy
Top oil temperature	30 °C	Humidity	100 %

Comments

--

Standard test

Corr. factor		1								
No.	Meas.	Test mode	Freq.	V out	I out	Watt losses	PF meas	PF corr	Cap. meas	Assessment
1	H1	UST-A	60.00 Hz	10.00 kV	1.00 mA	31.02 mW	0.3115 %	0.3115 %	264.2 pF	Pass
2	H2	UST-A	60.00 Hz	10.00 kV	0.99 mA	28.01 mW	0.2826 %	0.2826 %	263.0 pF	Pass
3	H3	UST-A	60.00 Hz	10.00 kV	1.02 mA	34.24 mW	0.3373 %	0.3373 %	269.3 pF	Pass

Bushing H PF & CAP - C2

Ambient temperature	24 °C	Weather	Partly cloudy
Top oil temperature	30 °C	Humidity	100 %

Comments

--

Standard test

No.	Meas.	Test mode	Freq.	V out	I out	Watt losses	PF meas	PF corr	Cap. meas	Assessment
1	H1	GSTg-A	60.00 Hz	2.00 kV	0.43 mA	20.40 mW	2.3837 %	2.3837 %	564.6 pF	Pass
2	H2	GSTg-A	60.00 Hz	2.00 kV	0.43 mA	19.65 mW	2.2969 %	2.2969 %	564.4 pF	Pass
3	H3	GSTg-A	60.00 Hz	2.00 kV	0.39 mA	13.75 mW	1.7601 %	1.7601 %	517.9 pF	Pass

Bushing H – Energized Collar

Ambient temperature	24 °C	Weather	Partly cloudy
Top oil temperature	30 °C	Humidity	100 %

Comments

Standard test

No.	Meas.	Test mode	Freq.	V out	I out	Watt losses	Assessment
1	H1	UST-A	60.00 Hz	12.00 kV	0.08 mA	92.55 mW	Pass
2	H2	UST-A	60.00 Hz	12.00 kV	0.08 mA	71.09 mW	Pass
3	H3	UST-A	60.00 Hz	12.00 kV	0.09 mA	67.02 mW	Pass
4	H0	UST-A	60.00 Hz	12.00 kV	0.05 mA	56.90 mW	Pass

Bushing X – Energized Collar

Ambient temperature	24 °C	Weather	Partly cloudy
Top oil temperature	30 °C	Humidity	100 %

Comments

Standard test

No.	Meas.	Test mode	Freq.	V out	I out	Watt losses	Assessment
1	X1	UST-A	60.00 Hz	10.00 kV	0.08 mA	53.01 mW	Pass
2	X2	UST-A	60.00 Hz	10.00 kV	0.09 mA	42.43 mW	Pass
3	X3	UST-A	60.00 Hz	10.00 kV	0.10 mA	66.31 mW	Pass

Bushing Y – Energized Collar

Ambient temperature	24 °C	Weather	Partly cloudy
Top oil temperature	30 °C	Humidity	100 %

Comments

Standard test

No.	Meas.	Test mode	Freq.	V out	I out	Watt losses	Assessment
1	Y1	UST-A	60.00 Hz	10.00 kV	0.09 mA	44.19 mW	Pass
2	Y2	UST-A	60.00 Hz	10.00 kV	0.09 mA	59.96 mW	Pass
3	Y3	UST-A	60.00 Hz	10.00 kV	0.09 mA	45.15 mW	Pass

Exciting Current

Comment

--

Measurement settings

Test voltage	5 kV
Test frequency	60.00 Hz
Tap changer under test	DETC

Averaging	2
Bandwidth	±20 Hz
AvoidTestFrequency	No

Use reference voltage	No
-----------------------	----

Measurements (sorted by tap)

Tap	Phase	V out	I out	I phase	Watt losses	Reactance	Assessment
4	A	5.00 kV	145.914 mA	-60.88 °	355.112 W	29.941 kΩ	Pass
4	B	5.00 kV	114.474 mA	-61.58 °	272.449 W	38.414 kΩ	Pass
4	C	5.00 kV	152.329 mA	-60.75 °	372.244 W	28.638 kΩ	Pass

Surge Arrester Watt Losses H

Ambient temperature	24 °C	Weather	Partly cloudy
Top oil temperature	30 °C	Humidity	100 %

Comments

--

Standard test

Meas.	Position	Test mode	Freq.	V out	I out	Watt losses	Assessment
H1	1	GST	60.00 Hz	1.00 kV	0.03 mA	1.40 mW	Pass
H2	1	GST	60.00 Hz	1.00 kV	0.03 mA	1.75 mW	Pass
H3	1	GST	60.00 Hz	1.00 kV	0.03 mA	1.93 mW	Pass

TTR H-X

Comment

--

Measurement settings

Test voltage	400 V
Test frequency	60.00 Hz
Tap changer under test	DETC

Ratio	TTR*
-------	------

Measurements (sorted by tap)

Tap	Phase	Nom. Ratio	$V_{prim} (L-L)$	I_{prim}	$V_{sec} (L-L)$	V_{phase}	TTR*	Ratio dev	Assessment
4	A	2.9575	393.02 V	9.078 mA	76.79 V	30.91 °	2.9552	-0.08 %	Pass
4	B	2.9575	403.85 V	8.760 mA	77.57 V	29.66 °	3.0059	1.64 %	Pass
4	C	2.9575	399.91 V	6.239 mA	78.89 V	29.43 °	2.9266	-1.04 %	Pass

TTR H-Y

Comment

--

Measurement settings

Test voltage	400 V
Test frequency	60.00 Hz
Tap changer under test	DETC

Ratio	TTR*
-------	------

Measurements (sorted by tap)

Tap	Phase	Nom. Ratio	$V_{prim} (L-L)$	I_{prim}	$V_{sec} (L-L)$	V_{phase}	TTR*	Ratio dev	Assessment
4	A	2.9575	392.59 V	9.096 mA	76.71 V	30.97 °	2.9548	-0.09 %	Pass
4	B	2.9575	404.11 V	8.750 mA	77.55 V	29.64 °	3.0087	1.73 %	Pass
4	C	2.9575	399.91 V	6.256 mA	78.96 V	29.4 °	2.9243	-1.12 %	Pass

DC Winding Resistance H

Comment

--

Measurement settings

Test current	5 A
Output mode	16 A @ 340 V
	1 ph.
Measurement	L-N

Tap changer under test	DETC
------------------------	------

Winding temperature	20 °C
Reference temperature	75 °C
Temp. corr. factor (K)	1.216

Automatic result	True
Settling time (At)	5 s
Tolerance R dev	0.1 %
Recording time	200.0 ms

Tap	A (H1 - H0)			B (H2 - H0)			C (H3 - H0)		
	R meas	R dev	R corr	R meas	R dev	R corr	R meas	R dev	R corr
4	58.083 mΩ	0.070 %	70.636 mΩ	57.601 mΩ	0.016 %	70.049 mΩ	58.595 mΩ	0.067 %	71.258 mΩ

DC Winding Resistance X

Comment

--

Measurement settings

Test current	10 A
Output mode	16 A @ 340 V
	1 ph.

Automatic result	True
Settling time (At)	5 s
Tolerance R dev	0.1 %
Recording time	200.0 ms

A (X1 - X2)			B (X2 - X3)			C (X3 - X1)		
<i>R meas</i>	<i>R dev</i>	<i>R corr</i>	<i>R meas</i>	<i>R dev</i>	<i>R corr</i>	<i>R meas</i>	<i>R dev</i>	<i>R corr</i>
5.130 mΩ	0.354 %	5.130 mΩ	5.072 mΩ	0.577 %	5.072 mΩ	4.984 mΩ	0.338 %	4.984 mΩ

DC Winding Resistance Y

Comment

--

Measurement settings

Test current	10 A
Output mode	16 A @ 340 V
	1 ph.

Automatic result	True
Settling time (At)	5 s
Tolerance R dev	0.1 %
Recording time	200.0 ms

A (Y1 - Y2)			B (Y2 - Y3)			C (Y3 - Y1)		
<i>R meas</i>	<i>R dev</i>	<i>R corr</i>	<i>R meas</i>	<i>R dev</i>	<i>R corr</i>	<i>R meas</i>	<i>R dev</i>	<i>R corr</i>
4.907 mΩ	0.072 %	4.907 mΩ	4.903 mΩ	0.988 %	4.903 mΩ	4.871 mΩ	0.459 %	4.871 mΩ

Insulation Resistance

Comment

Test object temperature	50 °C
Reference temperature	20 °C

Ambient temperature	24 °C
Humidity	100 %

PI calculation	
Time 1	60 s
Time 2	600 s

DAR calculation	
Time 1	30 s
Time 2	60 s

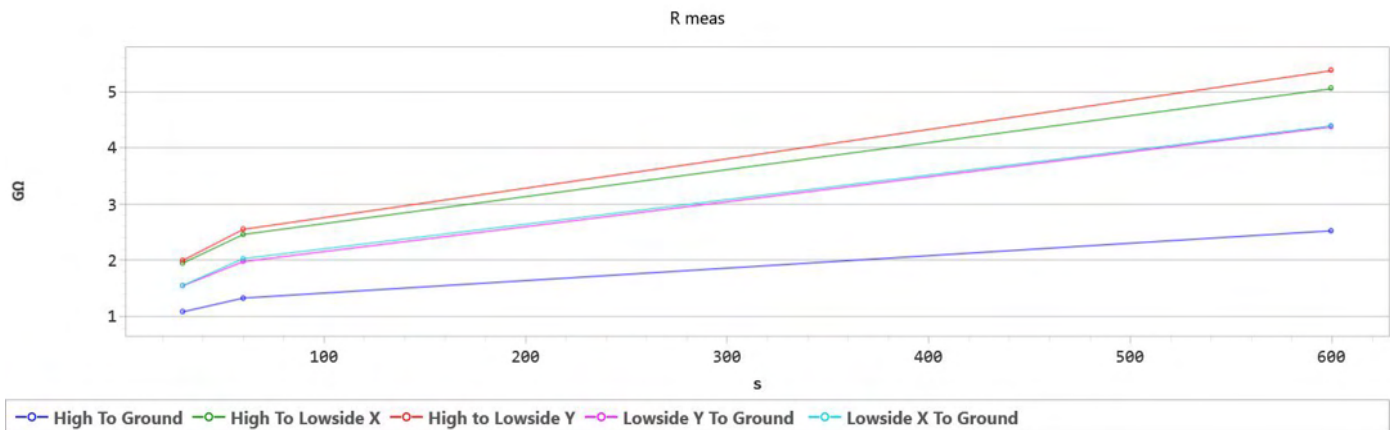

Name High To Ground				
PI	1.90	<input checked="" type="checkbox"/>	DAR	1.23 <input checked="" type="checkbox"/>

Time	R meas	R corr	V DC	I DC
30 s	1.084 GΩ	1.084 GΩ	10.00 kV	9.225 μA
60 s	1.329 GΩ	1.329 GΩ	10.00 kV	7.524 μA
600 s	2.525 GΩ	2.525 GΩ	10.00 kV	3.960 μA

Name High To Lowside X				
PI	2.05	<input checked="" type="checkbox"/>	DAR	1.26 <input checked="" type="checkbox"/>

Time	R meas	R corr	V DC	I DC
30 s	1.950 GΩ	1.950 GΩ	10.00 kV	5.128 μA
60 s	2.460 GΩ	2.460 GΩ	10.00 kV	4.065 μA
600 s	5.050 GΩ	5.050 GΩ	10.00 kV	1.980 μA

Name High to Lowside Y				
PI	2.11	<input checked="" type="checkbox"/>	DAR	1.28 <input checked="" type="checkbox"/>

Time	R meas	R corr	V DC	I DC
30 s	1.999 GΩ	1.999 GΩ	10.00 kV	5.003 μA
60 s	2.550 GΩ	2.550 GΩ	10.00 kV	3.922 μA
600 s	5.370 GΩ	5.370 GΩ	10.00 kV	1.862 μA

Name Lowside Y To Ground				
PI	2.21	<input checked="" type="checkbox"/>	DAR	1.28 <input checked="" type="checkbox"/>

Time	R meas	R corr	V DC	I DC
30 s	1.548 GΩ	1.548 GΩ	10.00 kV	6.460 μA
60 s	1.977 GΩ	1.977 GΩ	10.00 kV	5.058 μA
600 s	4.370 GΩ	4.370 GΩ	10.00 kV	2.288 μA

Name Lowside X To Ground				
PI	2.16	<input checked="" type="checkbox"/>	DAR	1.31 <input checked="" type="checkbox"/>

Time	R meas	R corr	V DC	I DC
30 s	1.552 GΩ	1.552 GΩ	10.00 kV	6.443 μA
60 s	2.030 GΩ	2.030 GΩ	10.00 kV	4.926 μA
600 s	4.390 GΩ	4.390 GΩ	10.00 kV	2.278 μA

2B - Dry Type Transformer



Client	Orange Cogen	OCFL2310066 - 2B - Dry Type	
Execution date	9/30/2023	Reason of the job	
Tested by	Matthew Falchetti	Location	Orange Cogen
Approved by		Asset	Transformer
Report ID	2	Asset type	Two-winding
Report issue date	10/13/2023 9:10:24 AM	Asset serial number	24-34785-01 1B
Work order		Manufacturer	ABB

Summary

Performed tests	Assessment
Overall PF & CAP	Pass
TTR H-X	Pass
DC Winding Resistance H	Pass
DC Winding Resistance X	Pass
Insulation Resistance	Pass

Overall Assessment	No Faults
--------------------	-----------

Tested by:
Andrew Kirk

Approved by:
Matthew Falchetti

Location & company information			
Location		Company	
Name	Orange Cogen	Company	HVA – P&C / Field Service
Region		Department	South
Division	South	Address	
Area		City	Lakeland
Plant	Orange Cogen	State/Province	Florida
Address	1901 S. Clear Springs Rd	Postal code	33811
City	Bartow	Country	United States
State/Province	Florida	Phone No.	
Postal code	33830	Fax No.	
Country	United States	E-mail	

Geo coordinates	
-----------------	--

Contact person	
Name	
Phone No. 1	
Phone No. 2	
Fax No.	
E-mail	

Comment

Transformer nameplate data			
Serial number	24-34785-01 1B	Apparatus ID	Transformer 1B
Manufacturer	ABB	Feeder	
Manufacturing year	1994	No. phases	3
Manufacturer type	Vent	Vector group	Dyn1

Comment

Voltage ratings			
Winding	Voltage L-L	Voltage L-N	Insul. level L-L
H	4.056 kV	kV	60 kV
X	0.480 kV	0.277 kV	10 kV

Power ratings		
Rated power	Cooling class	Temp. rise wind.
2.500 MVA	OA	

Current ratings at rated power		
Winding		
H	X	Rated power
A	A	2.500 MVA

Short-circuit rating		
Max. short-circuit current	kA	s

Impedances	
Ref. temp.	75 °C

Leakage reactance H - X

Zk[%]	Base power	Base voltage	Load losses Pk	OLTC position	DETC position
%	MVA	kV	W		

Zero sequence impedance

Base power	MVA
Base voltage	kV
Description	Z0[%]
Secondary	%

Others

Category	Distribution
Status	In operation
Tank type	n/a
Insulation medium	Dry type
Fluid insulation volume	gals
Fluid insulation weight	lbs
Total weight	lbs

Bushings nameplate data

Pos.	Serial No.	Manufact.	Manufacturer type	Man. year	Voltage L-ground	Max. system voltage	Rated current
H1					kV	kV	A
H2					kV	kV	A
H3					kV	kV	A
X1					kV	kV	A
X2					kV	kV	A
X3					kV	kV	A
X0					kV	kV	A

Pos.	Insul. level LL	Cap. (C1)	PF (C1)	Cap. (C2)	PF (C2)	Insulation type	Tap type
H1	V	pF	%	pF	%		
H2	V	pF	%	pF	%		
H3	V	pF	%	pF	%		
X1	V	pF	%	pF	%		
X2	V	pF	%	pF	%		
X3	V	pF	%	pF	%		
X0	V	pF	%	pF	%		

Tap Changers nameplate data**DETC**

Serial number	
Manufacturer	
Manufacturer type	Manual
Winding	H
Tap scheme	1...N
No. of taps	5

Tap	Voltage
1	4638.0 V
2	4264.0 V
3	4160.0 V

Tap	Voltage
4	4056.0 V
5	3952.0 V

Test set information		
-----------------------------	--	--

Model	Serial number	Calibration date
TESTRANO 600	EN907R	2023-02-20
CP TD12	EN043U	2023-02-27

Global test conditions			
-------------------------------	--	--	--

Weather		Humidity	%
Unit location		Ambient temperature	°C

Overall PF & CAP			
Ambient temperature	°C	Weather	
Top oil temperature	°C	Humidity	%

Comments

Standard test

Block 1: injection at H

Corr. temperature	°C
Corr. factor	1

No.	Meas.	Test mode	Freq.	V out	I out	Watt losses	PF meas	PF corr	Cap. meas	Assessment
1	ICH+ICHL	GST	60.00 Hz	2.00 kV	3.18 mA	4704.33 mW	0.5308 %	0.5308 %	2843.0 pF	Pass
2	ICH	GSTg-A	60.00 Hz	2.00 kV	1.87 mA	3550.68 mW	0.6913 %	0.6913 %	785.5 pF	Pass
3	ICHL	UST-A	60.00 Hz	2.00 kV	1.65 mA	1099.94 mW	0.4039 %	0.4039 %	2058.0 pF	Pass

Block 2: injection at X

Corr. temperature	°C
Corr. factor	1

No.	Meas.	Test mode	Freq.	V out	I out	Watt losses	PF meas	PF corr	Cap. meas	Assessment
4	ICL+ICLH	GST	60.00 Hz	0.10 kV	0.42 mA	36.91 mW	0.3438 %	0.3438 %	5445.7 pF	Pass
5	ICL	GSTg-A	60.00 Hz	0.10 kV	0.36 mA	33.78 mW	0.4583 %	0.4583 %	3410.0 pF	Pass
6	ICLH	UST-A	60.00 Hz	0.10 kV	0.08 mA	2.58 mW	0.6654 %	0.6654 %	2031.0 pF	Pass

TTR H-X

Comment

--

Measurement settings

Test voltage	120 V
Test frequency	60.00 Hz
Tap changer under test	DETC

Ratio	TTR*
-------	------

Measurements (sorted by tap)

Tap	Phase	Nom. Ratio	$V_{prim} (L-L)$	I_{prim}	$V_{sec} (L-L)$	V_{phase}	TTR*	Ratio dev	Assessment
4	A	14.6358	119.93 V	132.891 mA	14.16 V	330.01 °	14.6710	0.24 %	Pass
4	B	14.6358	119.93 V	87.733 mA	14.16 V	330.01 °	14.6705	0.24 %	Pass
4	C	14.6358	119.92 V	91.704 mA	14.16 V	330.01 °	14.6718	0.25 %	Pass

DC Winding Resistance H

Comment

--

Measurement settings

Test current	10 A	Tap changer under test	DETC
Output mode	33 A @ 170 V		
	1 ph.		

Automatic result	True
Settling time (At)	5 s
Tolerance R dev	0.1 %
Recording time	200.0 ms

Tap	A (H1 - H3)			B (H2 - H1)			C (H3 - H2)		
	<i>R meas</i>	<i>R dev</i>	<i>R corr</i>	<i>R meas</i>	<i>R dev</i>	<i>R corr</i>	<i>R meas</i>	<i>R dev</i>	<i>R corr</i>
4	35.624 mΩ	0.001 %	35.624 mΩ	35.578 mΩ	0.001 %	35.578 mΩ	35.697 mΩ	0.002 %	35.697 mΩ

DC Winding Resistance X

Comment

--

Measurement settings

Test current	10 A
Output mode	33 A @ 170 V
	1 ph.
Measurement	L-N

A (X1 - X0)			B (X2 - X0)			C (X3 - X0)		
<i>R meas</i>	<i>R dev</i>	<i>R corr</i>	<i>R meas</i>	<i>R dev</i>	<i>R corr</i>	<i>R meas</i>	<i>R dev</i>	<i>R corr</i>
254.627 $\mu\Omega$	0.007 %	254.627 $\mu\Omega$	247.770 $\mu\Omega$	0.006 %	247.770 $\mu\Omega$	262.773 $\mu\Omega$	0.004 %	262.773 $\mu\Omega$

Insulation Resistance

Comment

Test object temperature	°C
Reference temperature	20 °C

Ambient temperature	°C
Humidity	%

PI calculation	
Time 1	60 s
Time 2	600 s

DAR calculation	
Time 1	30 s
Time 2	60 s

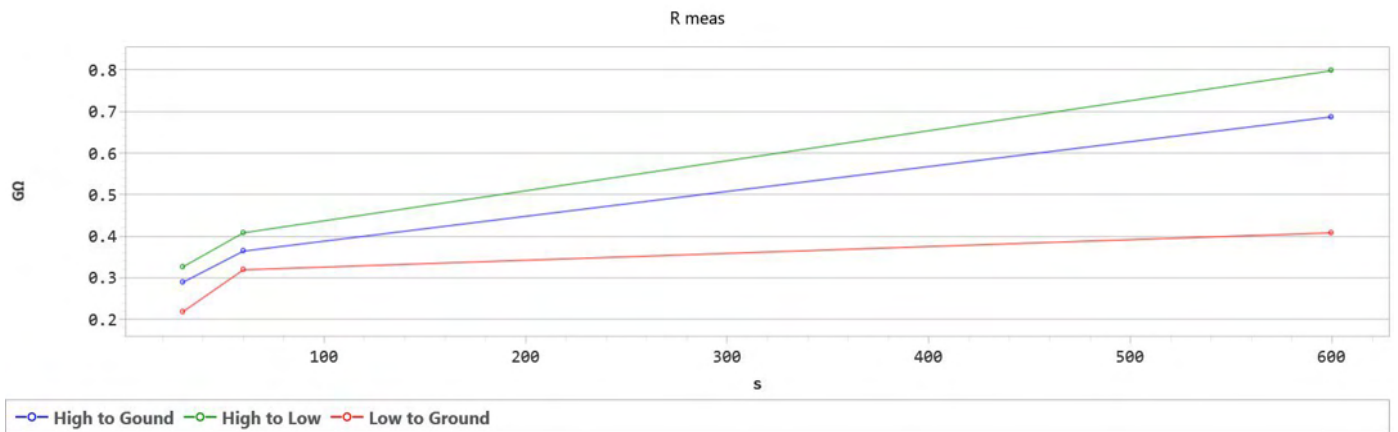

Name High to Gound				
PI	1.89	<input checked="" type="checkbox"/>	DAR	1.26 <input checked="" type="checkbox"/>

Time	R meas	R corr	V DC	I DC
30 s	289.000 MΩ	289.000 MΩ	5.00 kV	17.301 μA
60 s	364.000 MΩ	364.000 MΩ	5.00 kV	13.736 μA
600 s	687.000 MΩ	687.000 MΩ	5.00 kV	7.278 μA

Name High to Low				
PI	1.96	<input checked="" type="checkbox"/>	DAR	1.25 <input checked="" type="checkbox"/>

Time	R meas	R corr	V DC	I DC
30 s	326.000 MΩ	326.000 MΩ	5.00 kV	15.337 μA
60 s	408.000 MΩ	408.000 MΩ	5.00 kV	12.255 μA
600 s	798.000 MΩ	798.000 MΩ	5.00 kV	6.266 μA

Name Low to Ground				
PI	1.28	<input checked="" type="checkbox"/>	DAR	1.46 <input checked="" type="checkbox"/>

Time	R meas	R corr	V DC	I DC
30 s	218.000 MΩ	218.000 MΩ	500.00 V	2.294 μA
60 s	319.000 MΩ	319.000 MΩ	500.00 V	1.567 μA
600 s	408.000 MΩ	408.000 MΩ	500.00 V	1.225 μA

52 - T2 - SF-6 Breaker



Client	Orange Cogen	OCFL2310066 - 52 - T2	
Execution date	10/4/2023	Reason of the job	Routine
Tested by	Matthew Falchetti	Location	Orange Cogen
Approved by		Asset	Circuit breaker
Report ID	2	Asset type	Dead tank SF6 breaker
Report issue date	10/13/2023 9:02:29 AM	Asset serial number	48325-1
Work order		Manufacturer	Siemens

Summary
DLRO Readings - Closed Breaker A - phase - 112 micro B - phase - 110 micro C - phase - 110 micro

Performed tests	Assessment
C Timing	Pass
O Timing	Pass
CO Timing	Pass
OC Timing	Pass
O-CO Timing	Pass
Insulation Resistance	Pass

Overall Assessment	No Faults
--------------------	-----------

Tested by:
Andrew Kirk

Approved by:
Matthew Falchetti

Location & company information

Location		Company	
Name	Orange Cogen	Company	HVA – P&C / Field Services
Region		Department	South
Division	South	Address	
Area		City	Lakeland
Plant	Orange Cogen	State/Province	Florida
Address	1901 S. Clear Springs Rd	Postal code	33811
City	Bartow	Country	United States
State/Province	Florida	Phone No.	
Postal code	33830	Fax No.	
Country	United States	E-mail	

Geo coordinates	
-----------------	--

Contact person	
Name	
Phone No. 1	
Phone No. 2	
Fax No.	
E-mail	

Comment

Dead tank SF6 breaker nameplate data

Serial number	48325-1	No. of interrupters p. phase	1
Manufacturer	Siemens	Pole operation	Ganged
Manufacturing year	1994	Pre-insertion resistors	No
Manufacturer type	SPS-72.5-40-1	PIR value	Ω
Asset system code		Grading capacitors	Yes
Apparatus ID	52-T2	Capacitor value	pF
Feeder		Interrupting medium	SF6
No. of phases	3	Tank type	Dead tank

Comment

Ratings

Rated frequency	60.00 Hz
Rated voltage L-L	72.5 kV
Rated current	2000.0 A
Rated SC breaking current	40.0 kA
Short-circuit nominal duration	s
Rated insul. level L-G (BIL)	350.0 kV
Rated interrupting time	ms
Interrupting duty cycle	
Rated power at closing	W
Rated power at opening	W
Rated power at motor charge	W

Contact system

Total travel	in
Damping time	ms
Nozzle length	in

Others

Total weight with gas	4370 lbs
Weight of gas	15 lbs
Volume of gas	gals
Rated gas pressure	80.00 psi @ 21 °C

Spring Operating mechanism nameplate data

Serial No.	48325-1
Manufacturer	Siemens
Manufacturer type	SPS-SE
Manufacturing year	1994
Asset system code	52 -T2

Component	Rated voltage	Rated current	Frequency	
Trip coil 1	135.0 V	A	Hz	DC
Close coil 1	135.0 V	A	Hz	DC
Auxiliary circuits	V	A	Hz	DC
Motor	135.0 V	A	Hz	DC

Bushings nameplate data

Pos.	Serial No.	Manufact.	Man. year	Voltage L-ground	Max. system voltage	Rated current	Insul. level LL
1		LAPP		72.5 kV	72.5 kV	2000.0 A	V
2		LAPP		72.5 kV	72.5 kV	2000.0 A	V
3		LAPP		72.5 kV	72.5 kV	2000.0 A	V
4		LAPP		72.5 kV	72.5 kV	2000.0 A	V
5		LAPP		72.5 kV	72.5 kV	2000.0 A	V
6		LAPP		72.5 kV	72.5 kV	2000.0 A	V

Pos.	Cap. (C1)	PF (C1)	Cap. (C2)	PF (C2)	Insulation type	Tap type
1	pF	%	pF	%	Porcelain dry type	Without tap

Pos.	Cap. (C1)	PF (C1)	Cap. (C2)	PF (C2)	Insulation type	Tap type
2	pF	%	pF	%	Porcelain dry type	Without tap
3	pF	%	pF	%	Porcelain dry type	Without tap
4	pF	%	pF	%	Porcelain dry type	Without tap
5	pF	%	pF	%	Porcelain dry type	Without tap
6	pF	%	pF	%	Porcelain dry type	Without tap

Test set information

Model	Serial number	Calibration date
CIBANO 500	BM271E	2023-07-06
CB TN3	AL015E	2023-07-05

Global test conditions

Weather	Clear	Humidity	100 %
Unit location	Outside	Ambient temperature	23 °C

Operations counter

Counter reading found	39
Counter reading left	

C Timing

Execution date/Time	10/4/2023 11:28:46 AM	
Sequence	C	
Coil supply voltage	135.0 V DC	
Time calculation	According to IEC 62271-100	
Sample rate	10 kHz	

Transducer settings

CB TN3, Channel 1	5.0 V - 0.0125 ° (digital)
-------------------	----------------------------

Main, resistive and auxiliary contacts

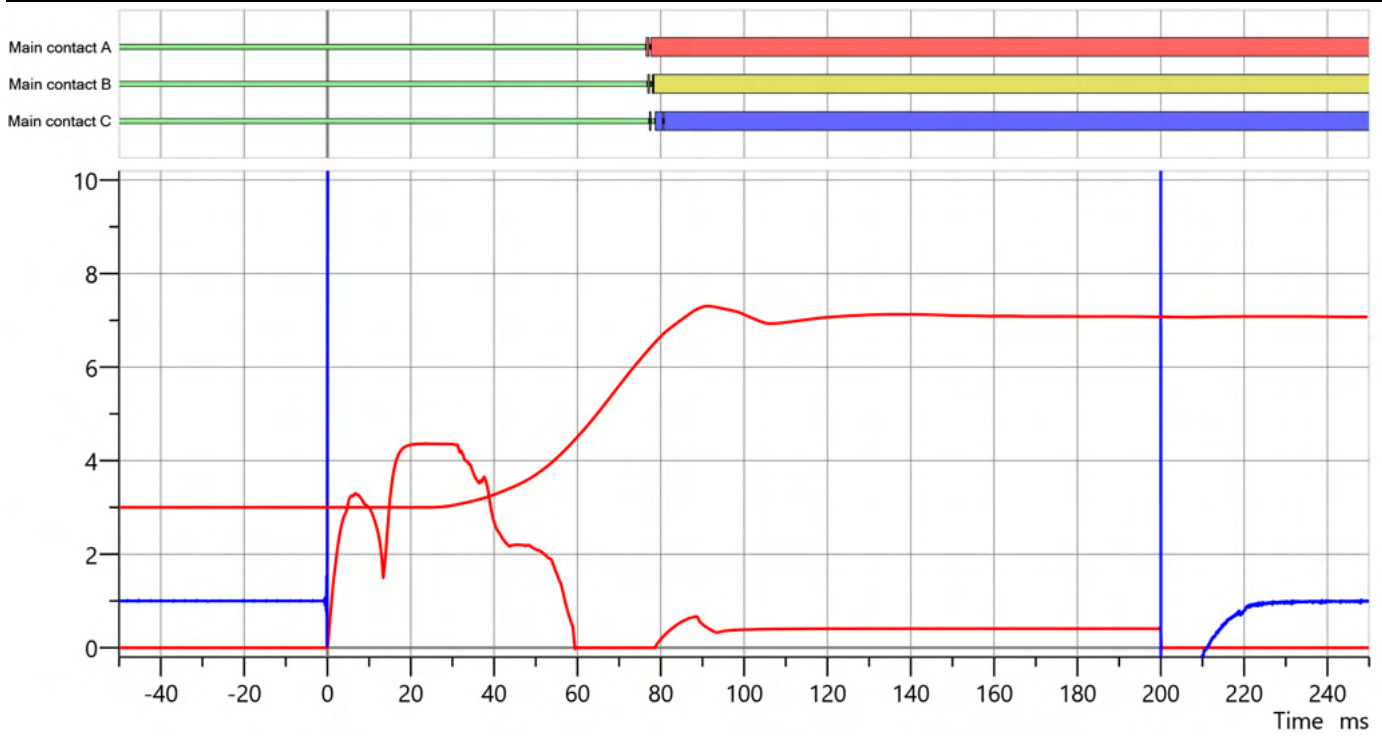

Label	Unit/div.	Y-Axis pos.	Label	Unit/div.	Y-Axis pos.		
Close coil (A)	■	1.00 A	0.00	Channel 1 (travel)	■	7.85 °	3.00
Close coil (V)	■	10.00 V	1.00				

Operating times

Meas.	Closing time (ms)	Closing sync. (ms)	Assessment
Breaker	77.20	0.80	Pass
A	76.40		Pass
Main contact A	76.40		Pass
B	76.80		Pass
Main contact B	76.80		Pass
C	77.20		Pass
Main contact C	77.20		Pass

Assessment Limits	t min	t max
Closing time	70.00 ms	90.00 ms
Closing sync. (contacts within a phase)	ms	ms
Closing sync. (between breaker phases)	ms	ms

Contact travel characteristics

Module	Channel	Total travel	Over-travel	Rebound	Damping dist. BLG	Damping time BLG	Assessment
CB TN3	Channel 1	31.98 °	1.81 °	1.11 °	°	ms	N. rated

Assessment Limits	d min	d max
Total travel, TT	in	in
Over-travel (Close), OT	in	in
Rebound (Close), RB	in	in
Contact wipe (Close), CW	in	in

Assessment Limits	Minimum	Maximum
Damping distance (Close)	in	in
Damping time (Close)	ms	ms

Main contact characteristics

Main contact	Travel data	Contact wipe	Reaction time	PIR close time	Bounce time	Bounce count	Assessment
Main contact A	Channel 1	6.03 °	29.90 ms	ms	1.20 ms	1	N. rated
Main contact B	No data		ms	ms	1.40 ms	2	N. rated
Main contact C	No data		ms	ms	3.40 ms	2	N. rated

Assessment Limits	Minimum	Maximum
Bounce time	ms	ms
Bounce count		
Reaction time	ms	ms

Coil characteristics

	Peak current (A)	Average current (A)	Average voltage (V)	Resistance (Ω)	Assessment
Close	4.37	3.19	132.09	41.39	N. rated

Assessment Limits	Minimum	Maximum
Peak close coil current	A	A
Peak trip coil current	A	A
Average close coil current	A	A
Average trip coil current	A	A
Average close coil voltage	V	V
Average trip coil voltage	V	V
Close coil resistance	Ω	Ω
Trip coil resistance	Ω	Ω

O Timing

Execution date/Time	10/4/2023 11:27:04 AM	
Sequence	O	
Coil supply voltage	135.0 V DC	
Time calculation	According to IEC 62271-100	
Sample rate	10 kHz	

Transducer settings

CB TN3, Channel 1	5.0 V - 0.0125 ° (digital)
-------------------	----------------------------

Main, resistive and auxiliary contacts

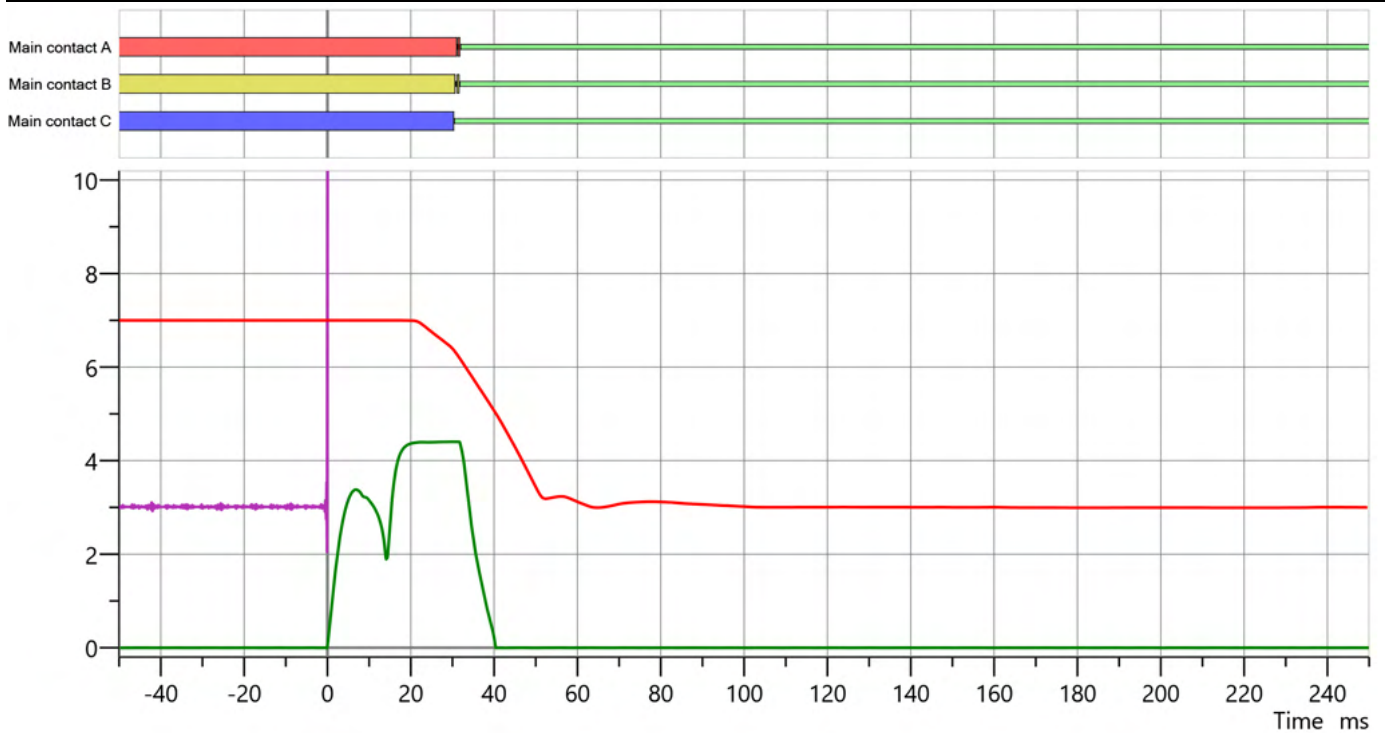

Label	Unit/div.	Y-Axis pos.	Label	Unit/div.	Y-Axis pos.		
Trip coil (A)	■	1.00 A	0.00	Channel 1 (travel)	■	7.87 °	2.99
Trip coil (V)	■	10.00 V	3.00				

Operating times

Meas.	Opening time (ms)	Opening sync. (ms)	Assessment
Breaker	31.90	1.50	Pass
A	31.90		Pass
Main contact A	31.90		Pass
B	31.70		Pass
Main contact B	31.70		Pass
C	30.40		Pass
Main contact C	30.40		Pass

Assessment Limits	t min	t max
Opening time	ms	32.00 ms
Opening sync. (contacts within a phase)	ms	ms
Opening sync. (between breaker phases)	ms	ms

Contact travel characteristics

Module	Channel	Total travel	Over-travel	Rebound	Damping distance	Assessment
CB TN3	Channel 1	31.46 °	0.06 °	0.95 °	°	N. rated

Assessment Limits	d min	d max
Total travel, TT	in	in
Over-travel (Trip), OT	in	in
Rebound (Trip), RB	in	in
Contact wipe (Trip), CW	in	in

Assessment Limits	Minimum	Maximum
Damping distance (Trip)	in	in

Main contact characteristics

Main contact	Travel data	Contact wipe	Reaction time	PIR close time	Bounce time	Bounce count	Assessment
Main contact A	Channel 1	6.55 °	22.00 ms	ms	0.80 ms	1	N. rated
Main contact B	No data		ms	ms	1.00 ms	1	N. rated
Main contact C	No data		ms	ms	0.00 ms	0	N. rated

Assessment Limits	Minimum	Maximum
Bounce time	ms	ms
Bounce count		
Reaction time	ms	ms

Coil characteristics

	Peak current (A)	Average current (A)	Average voltage (V)	Resistance (Ω)	Assessment
Trip A	4.40	3.52	131.98	37.46	N. rated

Assessment Limits	Minimum	Maximum
Peak close coil current	A	A
Peak trip coil current	A	A
Average close coil current	A	A
Average trip coil current	A	A
Average close coil voltage	V	V
Average trip coil voltage	V	V
Close coil resistance	Ω	Ω
Trip coil resistance	Ω	Ω

CO Timing

Execution date/Time	10/4/2023 11:28:07 AM	
Sequence	CO	
Coil supply voltage	135.0 V DC	
Sample rate	10 kHz	

Transducer settings

CB TN3, Channel 1	5.0 V - 0.0125 ° (digital)
-------------------	----------------------------

Main, resistive and auxiliary contacts

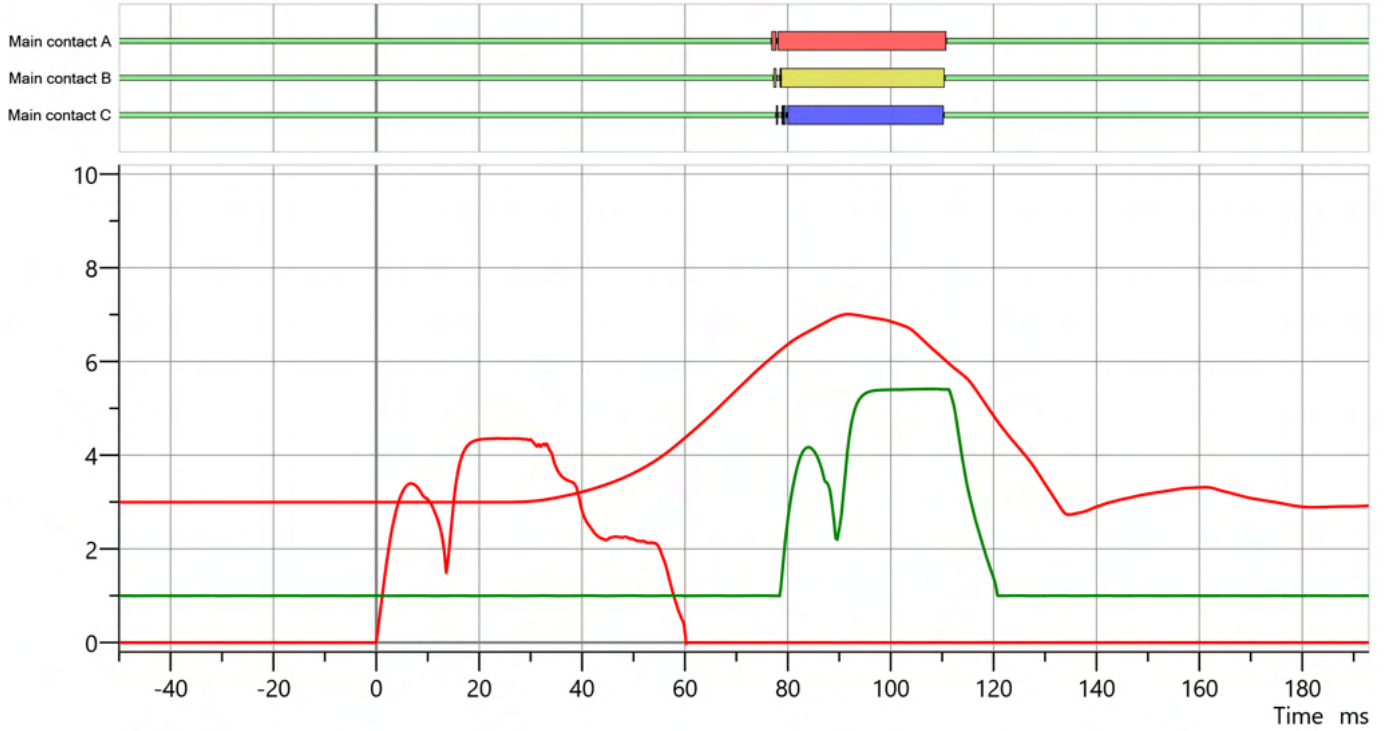

Label	Unit/div.	Y-Axis pos.	Label	Unit/div.	Y-Axis pos.		
Close coil (A)	■	1.00 A	0.00	Channel 1 (travel)	■	8.31 °	2.73
Trip coil (A)	■	1.00 A	1.00				

Operating times

Meas.	Closing time (ms)	Closing sync. (ms)	Close-Open time 1 (ms)	Assessment
Breaker	77.70	0.90	34.00	Pass
A	76.80		34.00	Pass
Main contact A	76.80		34.00	Pass
B	77.20		33.30	Pass
Main contact B	77.20		33.30	Pass
C	77.70		32.60	Pass
Main contact C	77.70		32.60	Pass

Assessment Limits	t min	t max
Closing time	70.00 ms	90.00 ms
Closing sync. (contacts within a phase)	ms	ms
Closing sync. (between breaker phases)	ms	ms
Close-Open time	ms	ms

Coil characteristics

	Peak current (A)	Average current (A)	Average voltage (V)	Resistance (Ω)	Assessment
Close	4.36				N. rated
Trip A	4.41				N. rated

Assessment Limits	Minimum	Maximum
Peak close coil current	A	A
Peak trip coil current	A	A

Comments

OC Timing

Execution date/Time	10/4/2023 11:30:52 AM	
Sequence	OC	
Coil supply voltage	135.0 V DC	
Sample rate	10 kHz	

Transducer settings

CB TN3, Channel 1	5.0 V - 0.0125 ° (digital)
-------------------	----------------------------

Main, resistive and auxiliary contacts

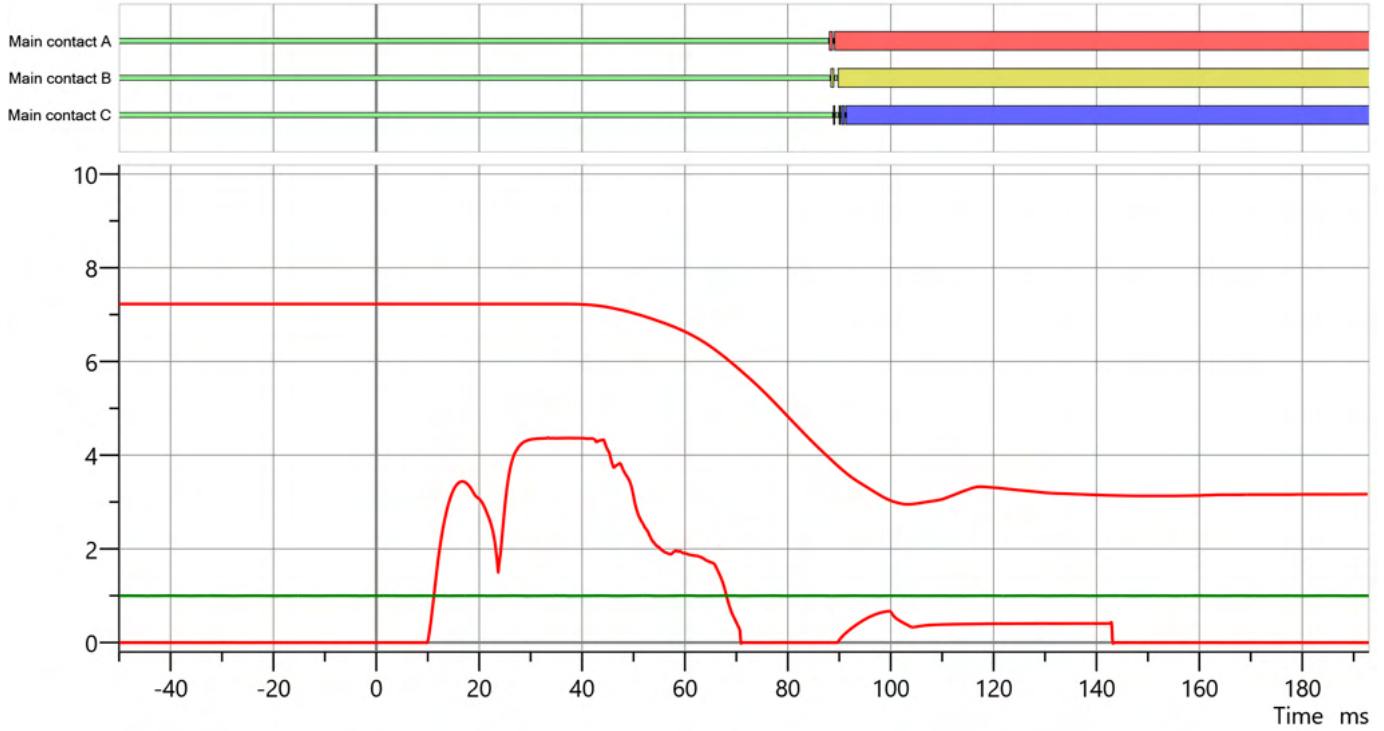

Label	Unit/div.	Y-Axis pos.	Label	Unit/div.	Y-Axis pos.		
Close coil (A)	■	1.00 A	0.00	Channel 1 (travel)	■	7.82 °	2.95
Trip coil (A)	■	1.00 A	1.00				

Operating times

Meas.	Opening time (ms)	Opening sync. (ms)	Reclosing time (ms)	Assessment
Breaker				N. rated
A				N. rated
Main contact A				N. rated
B				N. rated
Main contact B				N. rated
C				N. rated
Main contact C				N. rated

Assessment Limits	t min	t max
Opening time	ms	32.00 ms
Opening sync. (contacts within a phase)	ms	ms
Opening sync. (between breaker phases)	ms	ms
Reclosing time	ms	200.00 ms

Coil characteristics

	Peak current (A)	Average current (A)	Average voltage (V)	Resistance (Ω)	Assessment
Close	4.38				N. rated
Trip A	0.00				N. rated

Assessment Limits	Minimum	Maximum
Peak close coil current	A	A
Peak trip coil current	A	A

Comments

O-CO Timing

Execution date/Time	10/4/2023 11:31:32 AM	
Sequence	O-CO	
Coil supply voltage	135.0 V DC	
Sample rate	10 kHz	

Transducer settings

CB TN3, Channel 1	5.0 V - 0.0125 ° (digital)
-------------------	----------------------------

Main, resistive and auxiliary contacts

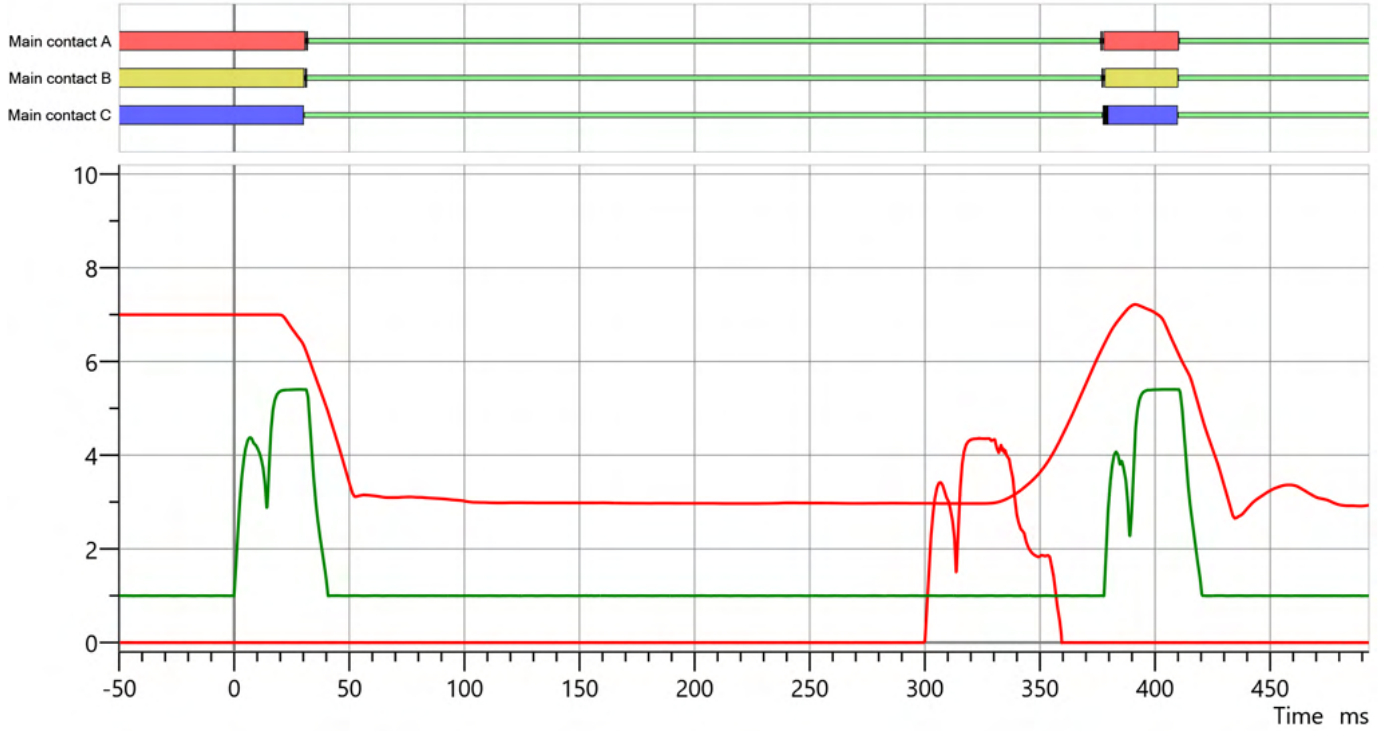

Label	Unit/div.	Y-Axis pos.	Label	Unit/div.	Y-Axis pos.		
Close coil (A)	■	1.00 A	0.00	Channel 1 (travel)	■	7.89 °	2.65
Trip coil (A)	■	1.00 A	1.00				

Operating times

Meas.	Opening time (ms)	Opening sync. (ms)	Closing time (ms)	Closing sync. (ms)	Open-Close time (ms)	Close-Open time 1 (ms)	Assessment
Breaker	32.00	1.80	77.30	1.00	344.30	34.10	Pass
A	32.00		76.30		344.30	34.10	Pass
Main contact A	32.00		76.30		344.30	34.10	Pass
B	31.30		76.80		345.50	33.30	Pass
Main contact B	31.30		76.80		345.50	33.30	Pass
C	30.20		77.30		347.10	32.60	Pass
Main contact C	30.20		77.30		347.10	32.60	Pass

Assessment Limits	t min	t max
Opening time	ms	32.00 ms
Opening sync. (contacts within a phase)	ms	ms
Opening sync. (between breaker phases)	ms	ms
Closing time	70.00 ms	90.00 ms
Closing sync. (contacts within a phase)	ms	ms
Closing sync. (between breaker phases)	ms	ms
Open-Close time	ms	ms
Close-Open time	ms	ms

Coil characteristics

	Peak current (A)	Average current (A)	Average voltage (V)	Resistance (Ω)	Assessment
Close	4.36				N. rated
Trip A	4.40				N. rated

Assessment Limits	Minimum	Maximum
Peak close coil current	A	A
Peak trip coil current	A	A

Comments

Insulation Resistance

Comment

Test object temperature	°C
Reference temperature	20 °C

Ambient temperature	23 °C
Humidity	100 %

PI calculation	
Time 1	60 s
Time 2	600 s

DAR calculation	
Time 1	30 s
Time 2	60 s

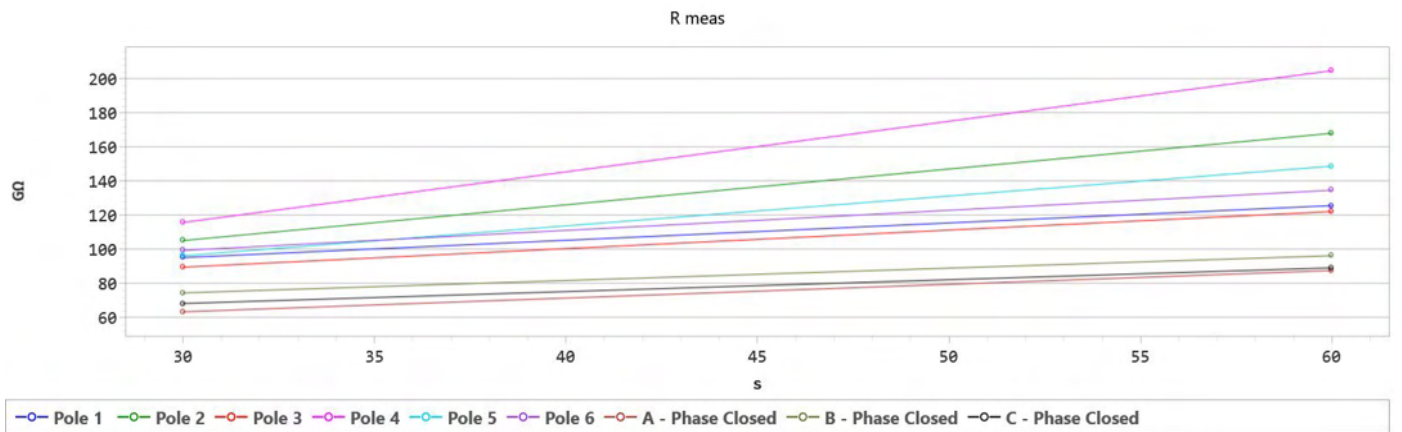

Name Pole 1				
PI		NaN	DAR	1.32

Time	R meas	R corr	V DC	I DC
30 s	95.200 GΩ	95.200 GΩ	5.00 kV	52.521 nA
60 s	125.700 GΩ	125.700 GΩ	5.00 kV	39.777 nA

Name Pole 2				
PI		NaN	DAR	1.60

Time	R meas	R corr	V DC	I DC
30 s	105.200 GΩ	105.200 GΩ	5.00 kV	47.529 nA
60 s	168.100 GΩ	168.100 GΩ	5.00 kV	29.744 nA

Name Pole 3				
PI		NaN	DAR	1.36

Time	R meas	R corr	V DC	I DC
30 s	89.600 GΩ	89.600 GΩ	5.00 kV	55.804 nA
60 s	122.200 GΩ	122.200 GΩ	5.00 kV	40.917 nA

Name Pole 4				
PI		NaN	DAR	1.77

Time	R meas	R corr	V DC	I DC
30 s	115.800 GΩ	115.800 GΩ	5.00 kV	43.178 nA
60 s	204.800 GΩ	204.800 GΩ	5.00 kV	24.414 nA

Name Pole 5				
PI		NaN	DAR	1.55

Time	R meas	R corr	V DC	I DC
30 s	96.300 GΩ	96.300 GΩ	5.00 kV	51.921 nA
60 s	148.800 GΩ	148.800 GΩ	5.00 kV	33.602 nA

Name Pole 6				
PI		NaN	DAR	1.36

Time	R meas	R corr	V DC	I DC
30 s	99.400 GΩ	99.400 GΩ	5.00 kV	50.302 nA
60 s	134.700 GΩ	134.700 GΩ	5.00 kV	37.120 nA

Name A - Phase Closed				
PI		NaN	DAR	1.38

Time	R meas	R corr	V DC	I DC
30 s	63.400 GΩ	63.400 GΩ	5.00 kV	78.864 nA
60 s	87.600 GΩ	87.600 GΩ	5.00 kV	57.078 nA

Name B - Phase Closed				
PI		NaN	DAR	1.29

Time	R meas	R corr	V DC	I DC
30 s	74.500 GΩ	74.500 GΩ	5.00 kV	67.114 nA
60 s	96.300 GΩ	96.300 GΩ	5.00 kV	51.921 nA

Name C - Phase Closed				
PI	NaN		DAR	1.31 

Time	R meas	R corr	V DC	I DC
30 s	68.300 GΩ	68.300 GΩ	5.00 kV	73.206 nA
60 s	89.200 GΩ	89.200 GΩ	5.00 kV	56.054 nA

52 - T1 - SF-6 Breaker



Client		OCFL2310066 - 52 - T1	
Execution date	10/5/2023	Reason of the job	Routine
Tested by	Matthew Falchetti	Location	Orange Cogen
Approved by		Asset	Circuit breaker
Report ID	2	Asset type	Dead tank SF6 breaker
Report issue date	10/13/2023 8:48:28 AM	Asset serial number	48326-2
Work order		Manufacturer	Siemens

Summary
DLRO Readings - Closed Breaker A - phase - 100 micro B - phase - 104 micro C - phase - 99 micro

Performed tests	Assessment
C Timing	Pass
O Timing	Pass
CO Timing	Pass
OC Timing	Pass
O-CO Timing	Pass
Insulation Resistance	Pass

Overall Assessment	No Faults
--------------------	-----------

Tested by:
Andrew Kirk

Approved by:
Matthew Falchetti

Location & company information

Location		Company	
Name	Orange Cogen	Company	HVA – P&C / Field Services
Region		Department	South
Division	South	Address	
Area		City	Lakeland
Plant	Orange Cogen	State/Province	Florida
Address	1901 S. Clear Springs Rd	Postal code	33811
City	Bartow	Country	United States
State/Province	Florida	Phone No.	
Postal code	33830	Fax No.	
Country	United States	E-mail	

Geo coordinates	
-----------------	--

Contact person	
Name	
Phone No. 1	
Phone No. 2	
Fax No.	
E-mail	

Comment

Dead tank SF6 breaker nameplate data

Serial number	48326-2	No. of interrupters p. phase	1
Manufacturer	Siemens	Pole operation	Ganged
Manufacturing year	1994	Pre-insertion resistors	No
Manufacturer type	SPS-72.5-40-1	PIR value	Ω
Asset system code		Grading capacitors	Yes
Apparatus ID	52-T1	Capacitor value	pF
Feeder		Interrupting medium	SF6
No. of phases	3	Tank type	Dead tank

Comment

Ratings

Rated frequency	60.00 Hz
Rated voltage L-L	72.5 kV
Rated current	2000.0 A
Rated SC breaking current	40.0 kA
Short-circuit nominal duration	s
Rated insul. level L-G (BIL)	350.0 kV
Rated interrupting time	ms
Interrupting duty cycle	
Rated power at closing	W
Rated power at opening	W
Rated power at motor charge	W

Contact system

Total travel	in
Damping time	ms
Nozzle length	in

Others

Total weight with gas	4370 lbs
Weight of gas	15 lbs
Volume of gas	gals
Rated gas pressure	80.00 psi @ 21 °C

Spring Operating mechanism nameplate data

Serial No.	48326-2
Manufacturer	Siemens
Manufacturer type	SPS-SE
Manufacturing year	1994
Asset system code	52 -T1

Component	Rated voltage	Rated current	Frequency	
Trip coil 1	135.0 V	A	Hz	DC
Close coil 1	135.0 V	A	Hz	DC
Auxiliary circuits	V	A	Hz	DC
Motor	135.0 V	A	Hz	DC

Bushings nameplate data

Pos.	Serial No.	Manufact.	Man. year	Voltage L-ground	Max. system voltage	Rated current	Insul. level LL
1		LAPP		72.5 kV	72.5 kV	2000.0 A	V
2		LAPP		72.5 kV	72.5 kV	2000.0 A	V
3		LAPP		72.5 kV	72.5 kV	2000.0 A	V
4		LAPP		72.5 kV	72.5 kV	2000.0 A	V
5		LAPP		72.5 kV	72.5 kV	2000.0 A	V
6		LAPP		72.5 kV	72.5 kV	2000.0 A	V

Pos.	Cap. (C1)	PF (C1)	Cap. (C2)	PF (C2)	Insulation type	Tap type
1	pF	%	pF	%	Porcelain dry type	Without tap

Pos.	Cap. (C1)	PF (C1)	Cap. (C2)	PF (C2)	Insulation type	Tap type
2	pF	%	pF	%	Porcelain dry type	Without tap
3	pF	%	pF	%	Porcelain dry type	Without tap
4	pF	%	pF	%	Porcelain dry type	Without tap
5	pF	%	pF	%	Porcelain dry type	Without tap
6	pF	%	pF	%	Porcelain dry type	Without tap

Test set information

Model	Serial number	Calibration date
CIBANO 500	BM271E	2023-07-06
CB TN3	AL015E	2023-07-05

Global test conditions

Weather	Clear	Humidity	94 %
Unit location	Outside	Ambient temperature	23 °C

Operations counter

Counter reading found	32
Counter reading left	

C Timing

Execution date/Time	10/5/2023 9:25:17 AM	
Sequence	C	
Coil supply voltage	135.0 V DC	
Time calculation	According to IEC 62271-100	
Sample rate	10 kHz	

Transducer settings

CB TN3, Channel 1	5.0 V - 0.0125 ° (digital)
-------------------	----------------------------

Main, resistive and auxiliary contacts

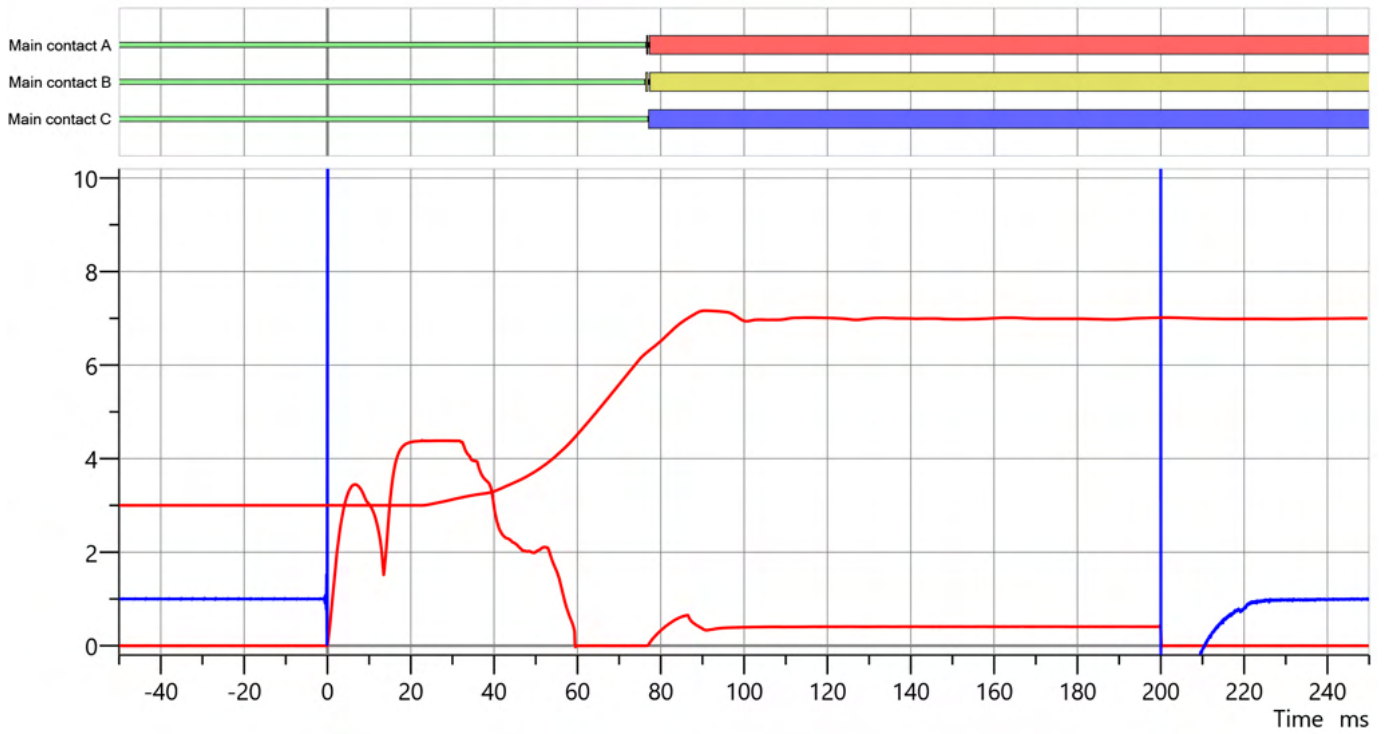

Label	Unit/div.	Y-Axis pos.	Label	Unit/div.	Y-Axis pos.		
Close coil (A)	■	1.00 A	0.00	Channel 1 (travel)	■	7.97 °	3.00
Close coil (V)	■	10.00 V	1.00				

Operating times

Meas.	Closing time (ms)	Closing sync. (ms)	Assessment
Breaker	77.00	0.70	Pass
A	76.50		Pass
Main contact A	76.50		Pass
B	76.30		Pass
Main contact B	76.30		Pass
C	77.00		Pass
Main contact C	77.00		Pass

Assessment Limits	t min	t max
Closing time	70.00 ms	90.00 ms
Closing sync. (contacts within a phase)	ms	ms
Closing sync. (between breaker phases)	ms	ms

Contact travel characteristics

Module	Channel	Total travel	Over-travel	Rebound	Damping dist. BLG	Damping time BLG	Assessment
CB TN3	Channel 1	31.89 °	1.30 °	0.49 °	°	ms	N. rated

Assessment Limits	d min	d max
Total travel, TT	in	in
Over-travel (Close), OT	in	in
Rebound (Close), RB	in	in
Contact wipe (Close), CW	in	in

Assessment Limits	Minimum	Maximum
Damping distance (Close)	in	in
Damping time (Close)	ms	ms

Main contact characteristics

Main contact	Travel data	Contact wipe	Reaction time	PIR close time	Bounce time	Bounce count	Assessment
Main contact A	Channel 1	5.90 °	25.60 ms	ms	0.70 ms	1	N. rated
Main contact B	No data		ms	ms	1.00 ms	1	N. rated
Main contact C	No data		ms	ms	0.00 ms	0	N. rated

Assessment Limits	Minimum	Maximum
Bounce time	ms	ms
Bounce count		
Reaction time	ms	ms

Coil characteristics

	Peak current (A)	Average current (A)	Average voltage (V)	Resistance (Ω)	Assessment
Close	4.39	3.24	132.08	40.72	N. rated

Assessment Limits	Minimum	Maximum
Peak close coil current	A	A
Peak trip coil current	A	A
Average close coil current	A	A
Average trip coil current	A	A
Average close coil voltage	V	V
Average trip coil voltage	V	V
Close coil resistance	Ω	Ω
Trip coil resistance	Ω	Ω

O Timing

Execution date/Time	10/5/2023 9:26:10 AM	
Sequence	O	
Coil supply voltage	135.0 V DC	
Time calculation	According to IEC 62271-100	
Sample rate	10 kHz	

Transducer settings

CB TN3, Channel 1	5.0 V - 0.0125 ° (digital)
-------------------	----------------------------

Main, resistive and auxiliary contacts

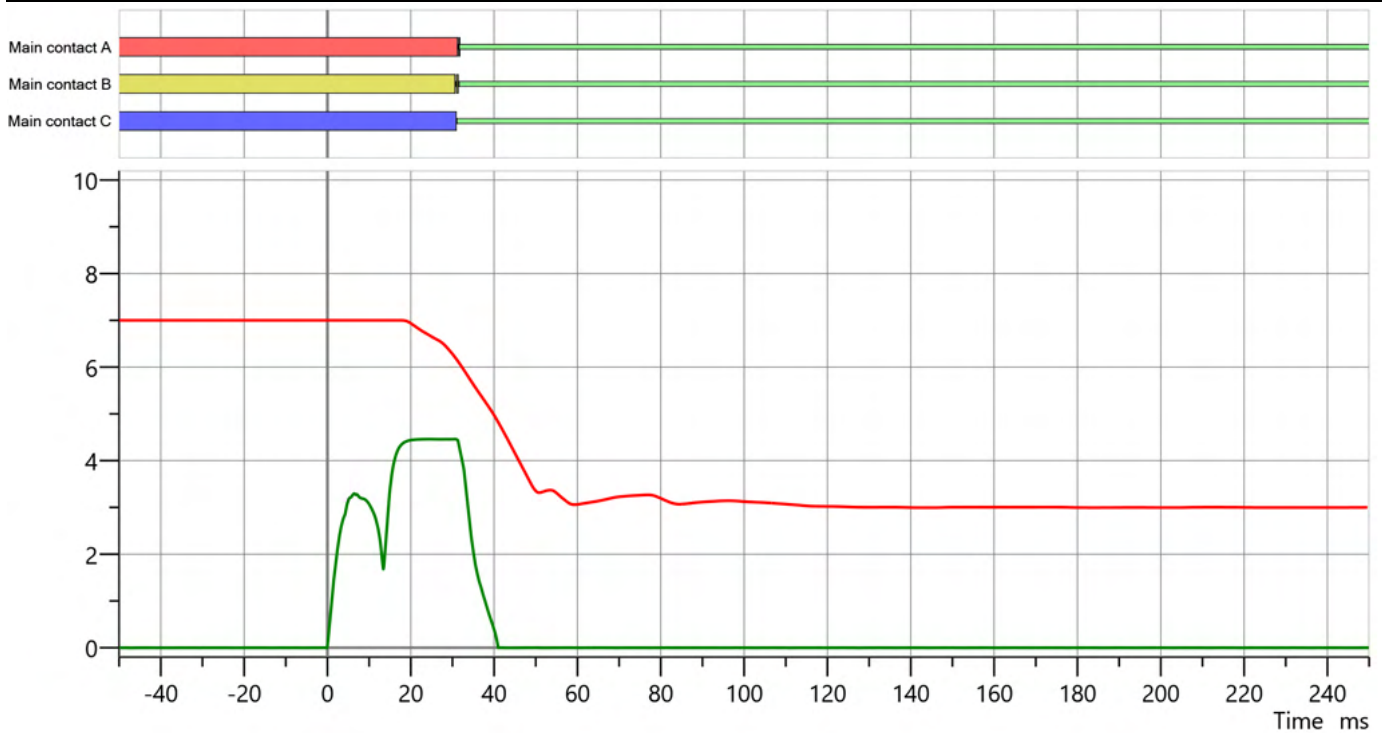

Label	Unit/div.	Y-Axis pos.	Label	Unit/div.	Y-Axis pos.
Trip coil (A)	1.00 A	0.00	Channel 1 (travel)	7.96 °	2.99

Operating times

Meas.	Opening time (ms)	Opening sync. (ms)	Assessment
Breaker	31.50	0.50	Pass
A	31.50		Pass
Main contact A	31.50		Pass
B	31.50		Pass
Main contact B	31.50		Pass
C	31.00		Pass
Main contact C	31.00		Pass

Assessment Limits	t min	t max
Opening time	ms	32.00 ms
Opening sync. (contacts within a phase)	ms	ms
Opening sync. (between breaker phases)	ms	ms

Contact travel characteristics

Module	Channel	Total travel	Over-travel	Rebound	Damping distance	Assessment
CB TN3	Channel 1	31.85 °	0.05 °	0.04 °	°	N. rated

Assessment Limits	d min	d max
Total travel, TT	in	in
Over-travel (Trip), OT	in	in
Rebound (Trip), RB	in	in
Contact wipe (Trip), CW	in	in

Assessment Limits	Minimum	Maximum
Damping distance (Trip)	in	in

Main contact characteristics

Main contact	Travel data	Contact wipe	Reaction time	PIR close time	Bounce time	Bounce count	Assessment
Main contact A	Channel 1	7.15 °	19.60 ms	ms	0.20 ms	1	N. rated
Main contact B	No data		ms	ms	0.80 ms	1	N. rated
Main contact C	No data		ms	ms	0.00 ms	0	N. rated

Assessment Limits	Minimum	Maximum
Bounce time	ms	ms
Bounce count		
Reaction time	ms	ms

Coil characteristics

	Peak current (A)	Average current (A)	Average voltage (V)	Resistance (Ω)	Assessment
Trip A	4.46	3.50	131.98	37.73	N. rated

Assessment Limits	Minimum	Maximum
Peak close coil current	A	A
Peak trip coil current	A	A
Average close coil current	A	A
Average trip coil current	A	A
Average close coil voltage	V	V
Average trip coil voltage	V	V
Close coil resistance	Ω	Ω
Trip coil resistance	Ω	Ω

CO Timing

Execution date/Time	10/5/2023 9:26:36 AM	
Sequence	CO	
Coil supply voltage	135.0 V DC	
Sample rate	10 kHz	

Transducer settings

CB TN3, Channel 1	5.0 V - 0.0125 ° (digital)
CB TN3, Channel 2	5.0 V - 0.0125 ° (digital)
CB TN3, Channel 3	5.0 V - 0.0125 ° (digital)

Main, resistive and auxiliary contacts

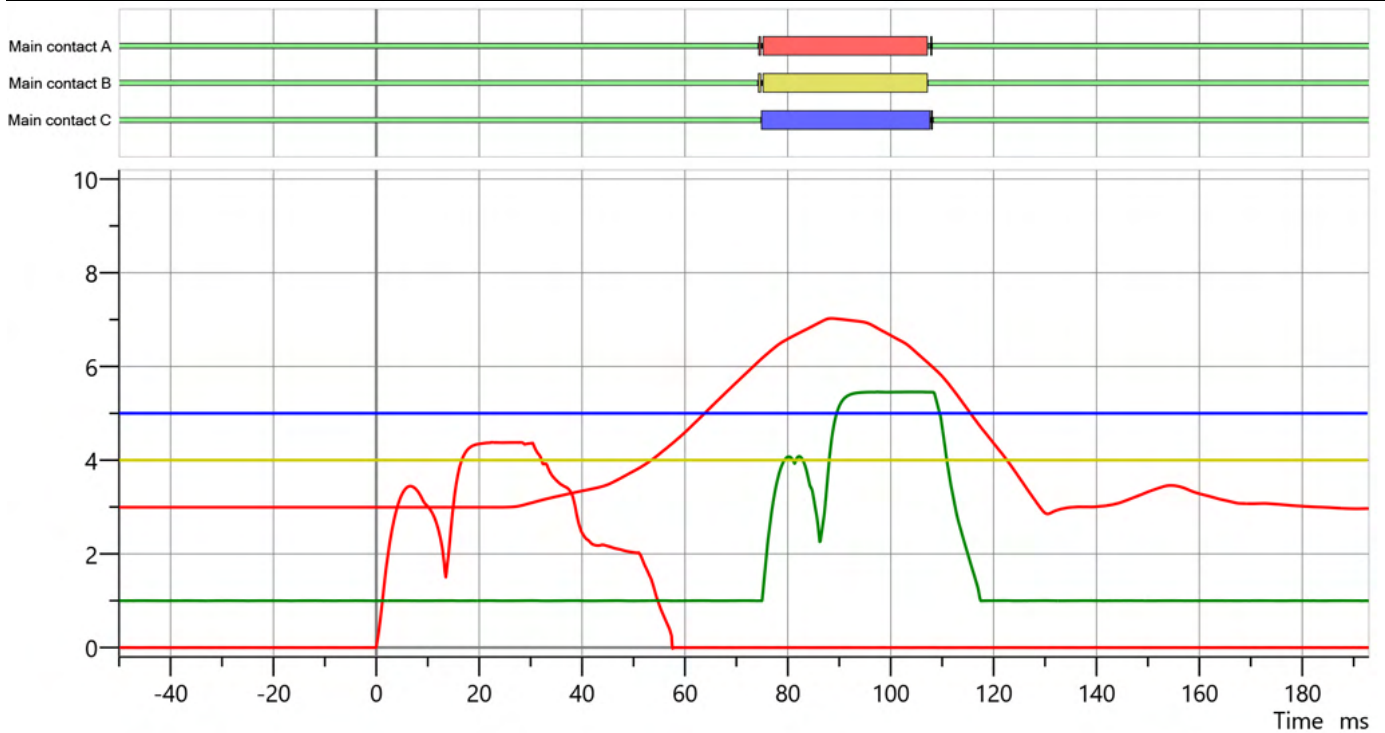

Label	Unit/div.	Y-Axis pos.	Label	Unit/div.	Y-Axis pos.
Close coil (A)	1.00 A	0.00	Channel 2 (travel)	1.00 °	4.00
Trip coil (A)	1.00 A	1.00	Channel 3 (travel)	1.00 °	5.00
Channel 1 (travel)	8.33 °	2.85			

Operating times

Meas.	Closing time (ms)	Closing sync. (ms)	Close-Open time 1 (ms)	Assessment
Breaker	74.80	0.60	34.00	Pass
A	74.30		33.70	Pass
Main contact A	74.30		33.70	Pass
B	74.20		33.00	Pass
Main contact B	74.20		33.00	Pass
C	74.80		33.40	Pass
Main contact C	74.80		33.40	Pass

Assessment Limits	t min	t max
Closing time	70.00 ms	90.00 ms
Closing sync. (contacts within a phase)	ms	ms
Closing sync. (between breaker phases)	ms	ms
Close-Open time	ms	ms

Coil characteristics

	Peak current (A)	Average current (A)	Average voltage (V)	Resistance (Ω)	Assessment
Close	4.38				N. rated
Trip A	4.46				N. rated

Assessment Limits	Minimum	Maximum
Peak close coil current	A	A
Peak trip coil current	A	A

Comments

OC Timing

Execution date/Time	10/5/2023 9:27:27 AM	
Sequence	OC	
Coil supply voltage	135.0 V DC	
Sample rate	10 kHz	

Transducer settings

CB TN3, Channel 1	5.0 V - 0.0125 ° (digital)
CB TN3, Channel 2	5.0 V - 0.0125 ° (digital)
CB TN3, Channel 3	5.0 V - 0.0125 ° (digital)

Main, resistive and auxiliary contacts

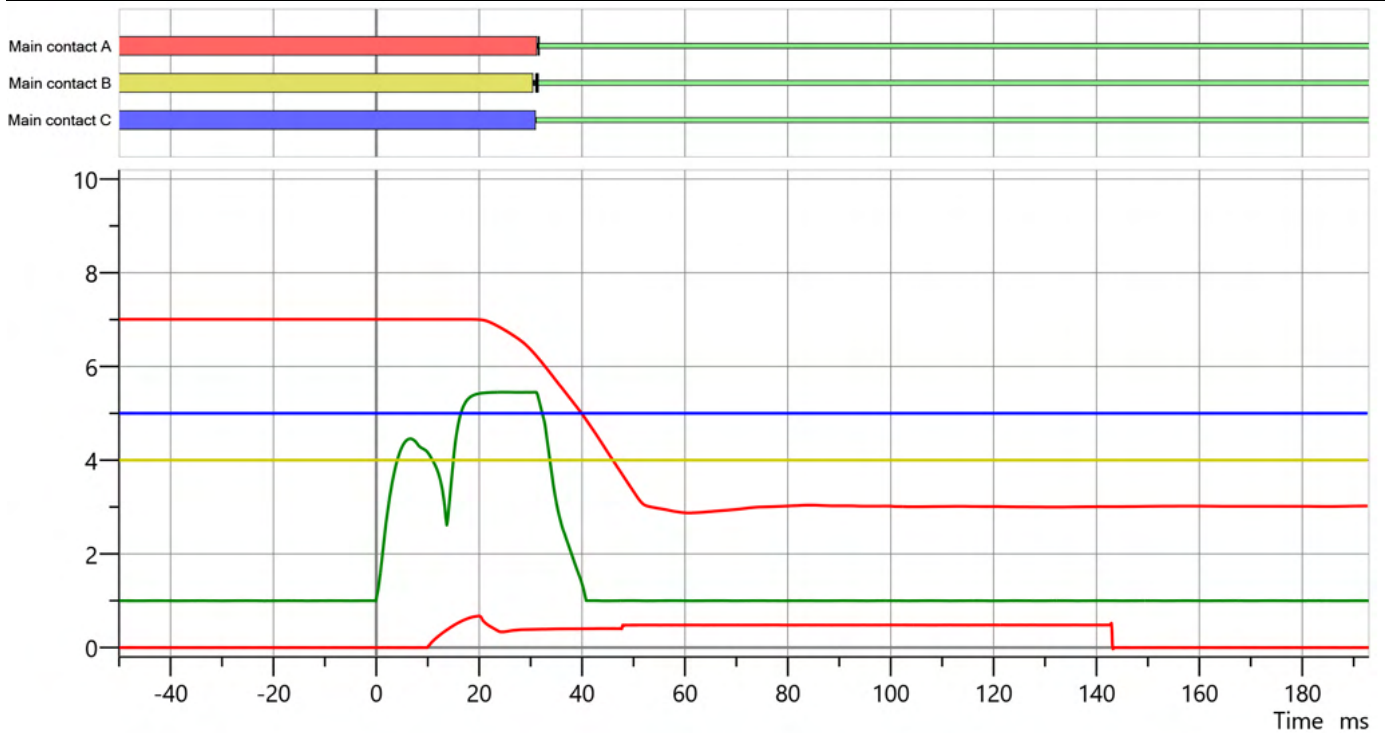

Label	Unit/div.	Y-Axis pos.	Label	Unit/div.	Y-Axis pos.
Close coil (A)	■ 1.00 A	0.00	Channel 2 (travel)	■ 1.00 °	4.00
Trip coil (A)	■ 1.00 A	1.00	Channel 3 (travel)	■ 1.00 °	5.00
Channel 1 (travel)	■ 7.76 °	2.87			

Operating times

Meas.	Opening time (ms)	Opening sync. (ms)	Reclosing time (ms)	Assessment
Breaker	31.50	0.50		Pass
A	31.50			Pass
Main contact A	31.50			Pass
B	31.40			Pass
Main contact B	31.40			Pass
C	31.00			Pass
Main contact C	31.00			Pass

Assessment Limits	t min	t max
Opening time	ms	32.00 ms
Opening sync. (contacts within a phase)	ms	ms
Opening sync. (between breaker phases)	ms	ms
Reclosing time	ms	200.00 ms

Coil characteristics

	Peak current (A)	Average current (A)	Average voltage (V)	Resistance (Ω)	Assessment
Close	0.67				N. rated
Trip A	4.45				N. rated

Assessment Limits	Minimum	Maximum
Peak close coil current	A	A
Peak trip coil current	A	A

Comments

O-CO Timing

Execution date/Time	10/5/2023 9:28:31 AM	
Sequence	O-CO	
Coil supply voltage	135.0 V DC	
Sample rate	10 kHz	

Transducer settings

CB TN3, Channel 1	5.0 V - 0.0125 ° (digital)
CB TN3, Channel 2	5.0 V - 0.0125 ° (digital)
CB TN3, Channel 3	5.0 V - 0.0125 ° (digital)

Main, resistive and auxiliary contacts

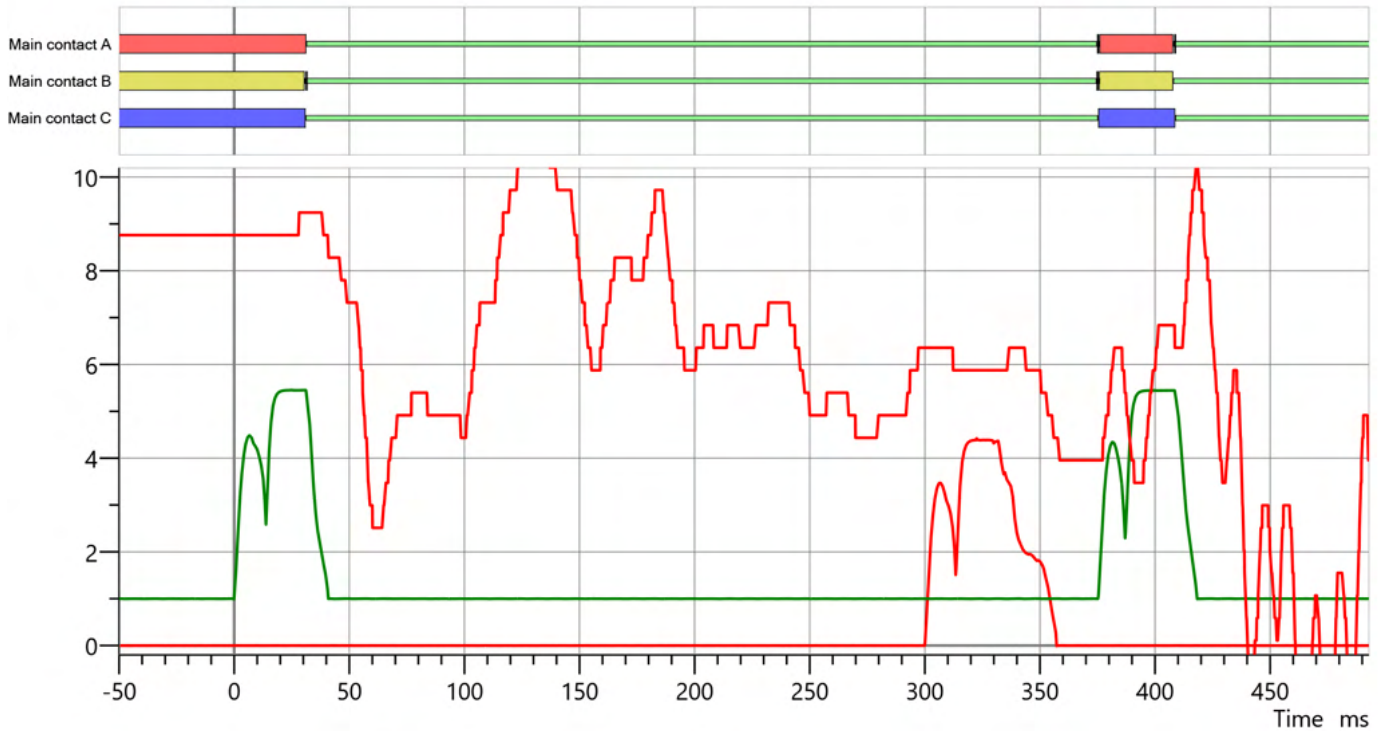

Label	Unit/div.	Y-Axis pos.	Label	Unit/div.	Y-Axis pos.
Close coil (A)	■ 1.00 A	0.00	Channel 2 (travel)	■ 1.00 °	-2.00
Trip coil (A)	■ 1.00 A	1.00	Channel 3 (travel)	■ 1.00 °	-1.00
Channel 1 (travel)	■ 0.03 °	-3.74			

Operating times

Meas.	Opening time (ms)	Opening sync. (ms)	Closing time (ms)	Closing sync. (ms)	Open-Close time (ms)	Close-Open time 1 (ms)	Assessment
Breaker	31.50	0.50	75.30	0.70	343.10	34.20	Pass
A	31.30		74.80		343.50	33.90	Pass
Main contact A	31.30		74.80		343.50	33.90	Pass
B	31.50		74.60		343.10	33.30	Pass
Main contact B	31.50		74.60		343.10	33.30	Pass
C	31.00		75.30		344.30	33.50	Pass
Main contact C	31.00		75.30		344.30	33.50	Pass

Assessment Limits	t min	t max
Opening time	ms	32.00 ms
Opening sync. (contacts within a phase)	ms	ms
Opening sync. (between breaker phases)	ms	ms
Closing time	70.00 ms	90.00 ms
Closing sync. (contacts within a phase)	ms	ms
Closing sync. (between breaker phases)	ms	ms
Open-Close time	ms	ms
Close-Open time	ms	ms

Coil characteristics

	Peak current (A)	Average current (A)	Average voltage (V)	Resistance (Ω)	Assessment
Close	4.42				N. rated
Trip A	4.45				N. rated

Assessment Limits	Minimum	Maximum
Peak close coil current	A	A
Peak trip coil current	A	A

Comments

Insulation Resistance

Comment

Test object temperature	°C
Reference temperature	20 °C

Ambient temperature	23 °C
Humidity	94 %

PI calculation	
Time 1	60 s
Time 2	600 s

DAR calculation	
Time 1	30 s
Time 2	60 s

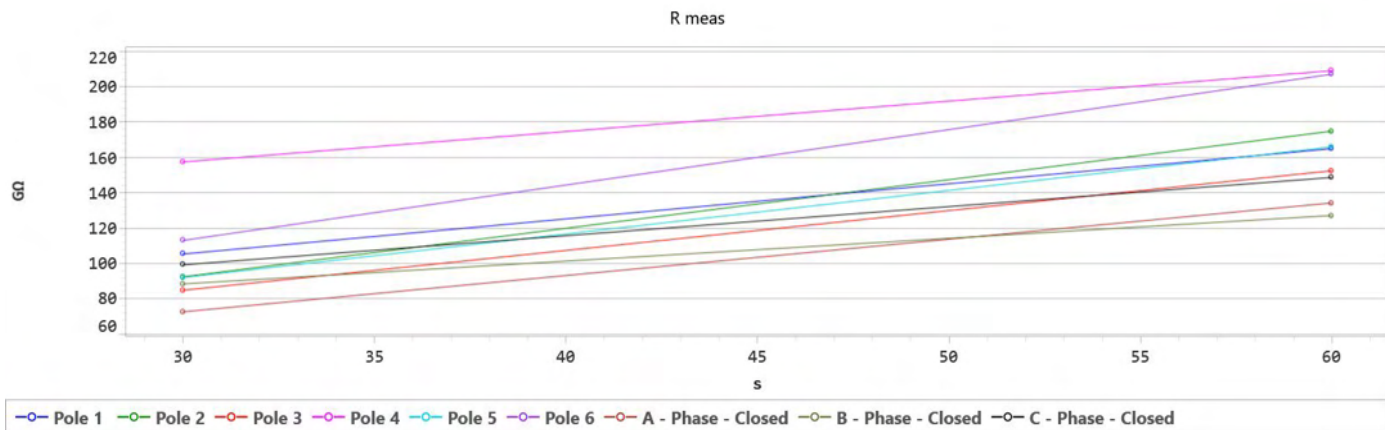

Name Pole 1				
PI	NaN		DAR	1.57

Time	R meas	R corr	V DC	I DC
30 s	105.300 GΩ	105.300 GΩ	5.00 kV	47.483 nA
60 s	164.900 GΩ	164.900 GΩ	5.00 kV	30.321 nA

Name Pole 2				
PI	NaN		DAR	1.89

Time	R meas	R corr	V DC	I DC
30 s	92.400 GΩ	92.400 GΩ	5.00 kV	54.113 nA
60 s	174.800 GΩ	174.800 GΩ	5.00 kV	28.604 nA

Name Pole 3				
PI	NaN		DAR	1.80

Time	R meas	R corr	V DC	I DC
30 s	84.800 GΩ	84.800 GΩ	5.00 kV	58.962 nA
60 s	152.400 GΩ	152.400 GΩ	5.00 kV	32.808 nA

Name Pole 4				
PI	NaN		DAR	1.33

Time	R meas	R corr	V DC	I DC
30 s	157.400 GΩ	157.400 GΩ	5.00 kV	31.766 nA
60 s	209.000 GΩ	209.000 GΩ	5.00 kV	23.923 nA

Name Pole 5				
PI	NaN		DAR	1.80

Time	R meas	R corr	V DC	I DC
30 s	92.000 GΩ	92.000 GΩ	5.00 kV	54.348 nA
60 s	165.900 GΩ	165.900 GΩ	5.00 kV	30.139 nA

Name Pole 6				
PI	NaN		DAR	1.83

Time	R meas	R corr	V DC	I DC
30 s	113.000 GΩ	113.000 GΩ	5.00 kV	44.248 nA
60 s	207.000 GΩ	207.000 GΩ	5.00 kV	24.155 nA

Name A - Phase - Closed				
PI	NaN		DAR	1.85

Time	R meas	R corr	V DC	I DC
30 s	72.600 GΩ	72.600 GΩ	5.00 kV	68.871 nA
60 s	134.200 GΩ	134.200 GΩ	5.00 kV	37.258 nA

Name B - Phase - Closed				
PI	NaN		DAR	1.44

Time	R meas	R corr	V DC	I DC
30 s	88.400 GΩ	88.400 GΩ	5.00 kV	56.561 nA
60 s	127.100 GΩ	127.100 GΩ	5.00 kV	39.339 nA

Name C - Phase - Closed				
PI	NaN		DAR	1.50 

Time	R meas	R corr	V DC	I DC
30 s	99.200 GΩ	99.200 GΩ	5.00 kV	50.403 nA
60 s	148.600 GΩ	148.600 GΩ	5.00 kV	33.647 nA



Orange Cogen

Test Reports

Ground Grid

Job #OCFL2310067



Empowering Electrical Infrastructure
for a Sustainable Future



Testing and Commissioning Services

6625 Network Way, Indianapolis, IN 46278

www.hva-inc.com/pc-field-services/

Equipment Tested: Ground Grid

Scope of Work: Point to Point testing

Observations and Recommendations:

Results: Missing ground tails and some bad

connections that need to be fixed.

GROUND RESISTIVITY TEST



CUSTOMER Orange Cogen PAGE _____
 ADDRESS 1901 S. Clear Springs Rd; Bartow FL 33830 DATE 8/3/2023
 OWNER Orange Cogen; 1901 S. Clear Springs Rd; Bartow FL 33830 JOB # OCFL2310067
 SITE Orange Cogen TEST STATUS _____ Pass
 SUBSTATION Ground Grid ASSET ID 2055 E100
 EQUIPMENT 2055 E100 AMBIENT TEMPERATURE 80 °F HUMIDITY 66 %

SOIL TYPE Normal Ground with grass and pavement SOIL CONDITION: DRY DAMP WET

TEST PLOT ID #	METER READING (OHMS)
RP #1	0.32
2	16.4
3	13.9
4	14.8
5	36.9
6	22.7
7	18.7
8	40.1
9	36.2
10	40.1
11	32.1
12	46.1
13	39.7
14	31.2
15	14.5

TEST PLOT ID #	METER READING (OHMS)
16	2.4
17	41.1
18	40.5
19	40.3
20	47.7
21	46.2
22	0.20
RP #2	0.32
2	0.32
3	0.40
4	0.31
5	0.32
6	0.66
7	0.68
8	0.21

TEST PLOT ID #	METER READING (OHMS)
9	0.32
10	0.32
11	0.93
RP #3	0.60
2	0.50
3	0.81
4	0.42
5	0.41
6	0.32
7	0.32
8	0.61
9	0.62

GROUND RESISTIVITY TEST



PAGE _____

COMMENTS:

DEFICIENCIES:

EQUIPMENT USED:

#	Manufacturer	Model	Serial / ID Number	Type	Calibration Date	Calibration Due
1	FLUKE	FLUKE - 87V	38210208	MULTIMETER	1/14/2023	1/14/2024
2	ETCR	ETCR3000C	30530077	EARTH RES. T	1/13/2023	1/13/2024

GROUND RESISTIVITY TEST



CUSTOMER Orange Cogen PAGE _____
 ADDRESS 1901 S. Clear Springs Rd; Bartow FL 33830 DATE 8/3/2023
 OWNER Orange Cogen; 1901 S. Clear Springs Rd; Bartow FL 33830 JOB # OCFL2310067
 SITE Orange Cogen TEST STATUS _____ Pass _____
 SUBSTATION Ground Grid ASSET ID 2055 E101-1
 EQUIPMENT 2055 E101-1 AMBIENT TEMPERATURE 80 °F HUMIDITY 66 %

SOIL TYPE Normal Ground with grass and pavement SOIL CONDITION: DRY DAMP WET

TEST PLOT ID #	METER READING (OHMS)
RP #4	0.22
2	0.28
3	0.27
4	0.27
5	0.27
6	0.27
7	0.28
8	0.27
9	0.28
10	0.27
11	0.27
12	0.27
13	0.27
14	0.42
15	0.46

TEST PLOT ID #	METER READING (OHMS)
16	0.27
17	0.25
18	0.28
19	0.29
20	0.27
21	0.27
22	0.27
23	0.28
24	0.27
25	0.27
26	0.27
27	0.27
28	0.27
29	0.27
30	0.26

TEST PLOT ID #	METER READING (OHMS)
31	0.27
32	0.27
33	0.27
34	0.28
35	0.27
36	0.27
37	0.49
38	0.28
39	0.27
40	0.28
41	0.28
42	0.27
43	0.29
44	0.28
45	0.28

GROUND RESISTIVITY TEST



PAGE _____

COMMENTS:

DEFICIENCIES:

EQUIPMENT USED

#	Manufacturer	Model	Serial / ID Number	Type	Calibration Date	Calibration Due
1	FLUKE	FLUKE - 87V	38210208	MULTIMETER	1/14/2023	1/14/2024
2	ETCR	ETCR3000C	30530077	EARTH RES. T	1/13/2023	1/13/2024

GROUND RESISTIVITY TEST



CUSTOMER Orange Cogen PAGE _____
 ADDRESS 1901 S. Clear Springs Rd; Bartow FL 33830 DATE 8/3/2023
 OWNER Orange Cogen; 1901 S. Clear Springs Rd; Bartow FL 33830 JOB # OCFL2310067
 SITE Orange Cogen TEST STATUS _____ Pass
 SUBSTATION Ground Grid ASSET ID 2055 E101-1 CONT.
 EQUIPMENT 2055 E101-1 AMBIENT TEMPERATURE 80 °F HUMIDITY 66 %

SOIL TYPE Normal Ground with grass and pavement SOIL CONDITION: DRY DAMP WET

TEST PLOT ID #	METER READING (OHMS)
46	0.27
47	0.28
48	0.28
49	0.28
50	0.27
51	0.27
52	0.27
53	0.27
54	0.28
55	0.28
56	0.27
57	0.28
58	0.27

TEST PLOT ID #	METER READING (OHMS)

TEST PLOT ID #	METER READING (OHMS)

GROUND RESISTIVITY TEST



PAGE _____

COMMENTS:

DEFICIENCIES:

EQUIPMENT USED:

#	Manufacturer	Model	Serial / ID Number	Type	Calibration Date	Calibration Due
1	FLUKE	FLUKE - 87V	38210208	MULTIMETER	1/14/2023	1/14/2024
2	ETCR	ETCR3000C	30530077	EARTH RES. T	1/13/2023	1/13/2024

GROUND RESISTIVITY TEST



CUSTOMER Orange Cogen PAGE _____
 ADDRESS 1901 S. Clear Springs Rd; Bartow FL 33830 DATE 8/3/2023
 OWNER Orange Cogen; 1901 S. Clear Springs Rd; Bartow FL 33830 JOB # OCFL2310067
 SITE Orange Cogen TEST STATUS _____ Pass
 SUBSTATION Ground Grid ASSET ID 2055 E104
 EQUIPMENT 2055 E104 AMBIENT TEMPERATURE 80 °F HUMIDITY 66 %

SOIL TYPE Normal Ground with grass and pavement SOIL CONDITION: DRY DAMP WET

TEST PLOT ID #	METER READING (OHMS)
RP #5	0.30
2	32.5
3	8.9
4	5.1
5	0.78
6	18.1
7	22.4
8	14.1
9	0.80
10	0.50
11	0.20
12	0.20
13	0.30
14	0.20
15	0.28

TEST PLOT ID #	METER READING (OHMS)
16	0.20
17	0.20
18	0.30
19	30.3
20	33.0
RP #6	0.30
2	14.0
3	34.1
4	30.3
5	23.4
6	9.0
7	8.0
8	0.30
9	0.40
10	0.30

TEST PLOT ID #	METER READING (OHMS)
11	0.30
12	0.22
13	0.21
14	0.30
15	0.50
16	0.20
17	0.30
18	31.1
19	34.0

GROUND RESISTIVITY TEST



PAGE _____

COMMENTS:

DEFICIENCIES:

EQUIPMENT USED

#	Manufacturer	Model	Serial / ID Number	Type	Calibration Date	Calibration Due
1	FLUKE	FLUKE - 87V	38210208	MULTIMETER	1/14/2023	1/14/2024
2	ETCR	ETCR3000C	30530077	EARTH RES. T	1/13/2023	1/13/2024

GROUND RESISTIVITY TEST



CUSTOMER Orange Cogen PAGE _____
 ADDRESS 1901 S. Clear Springs Rd; Bartow FL 33830 DATE 8/3/2023
 OWNER Orange Cogen; 1901 S. Clear Springs Rd; Bartow FL 33830 JOB # OCFL2310067
 SITE Orange Cogen TEST STATUS _____ Pass _____
 SUBSTATION Ground Grid ASSET ID _____ 2055 E105 _____
 EQUIPMENT 2055 E105 AMBIENT TEMPERATURE 80 °F HUMIDITY 66 %

SOIL TYPE _____ Normal Ground with grass and pavement _____ SOIL CONDITION: DRY DAMP WET

TEST PLOT ID #	METER READING (OHMS)
RP #7	0.22
1	0.21
2	0.22
3	0.32
4	0.32
5	0.44
6	0.42
7	0.44
8	0.30

TEST PLOT ID #	METER READING (OHMS)

TEST PLOT ID #	METER READING (OHMS)

GROUND RESISTIVITY TEST



PAGE _____

COMMENTS:

DEFICIENCIES:

EQUIPMENT USED:

#	Manufacturer	Model	Serial / ID Number	Type	Calibration Date	Calibration Due
1	FLUKE	FLUKE - 87V	38210208	MULTIMETER	1/14/2023	1/14/2024
2	ETCR	ETCR3000C	30530077	EARTH RES. T	1/13/2023	1/13/2024

GROUND RESISTIVITY TEST



CUSTOMER Orange Cogen PAGE _____
 ADDRESS 1901 S. Clear Springs Rd; Bartow FL 33830 DATE 8/3/2023
 OWNER Orange Cogen; 1901 S. Clear Springs Rd; Bartow FL 33830 JOB # OCFL2310067
 SITE Orange Cogen TEST STATUS _____ Pass _____
 SUBSTATION Ground Grid ASSET ID 2055 E106
 EQUIPMENT 2055 E106 AMBIENT TEMPERATURE 80 °F HUMIDITY 66 %

SOIL TYPE Normal Ground with grass and pavement SOIL CONDITION: DRY DAMP WET

TEST PLOT ID #	METER READING (OHMS)
RP #8	0.32
2	0.32
3	0.30
4	0.31
5	0.33
6	0.32
7	0.32
8	0.32
9	0.32
10	0.32
11	0.32
12	0.32
13	0.32
14	0.30
15	0.30

TEST PLOT ID #	METER READING (OHMS)

TEST PLOT ID #	METER READING (OHMS)

GROUND RESISTIVITY TEST



PAGE _____

COMMENTS:

DEFICIENCIES:

EQUIPMENT USED:

#	Manufacturer	Model	Serial / ID Number	Type	Calibration Date	Calibration Due
1	FLUKE	FLUKE - 87V	38210208	MULTIMETER	1/14/2023	1/14/2024
2	ETCR	ETCR3000C	30530077	EARTH RES. T	1/13/2023	1/13/2024

A B C D E F

CLEAR SPRINGS ROAD

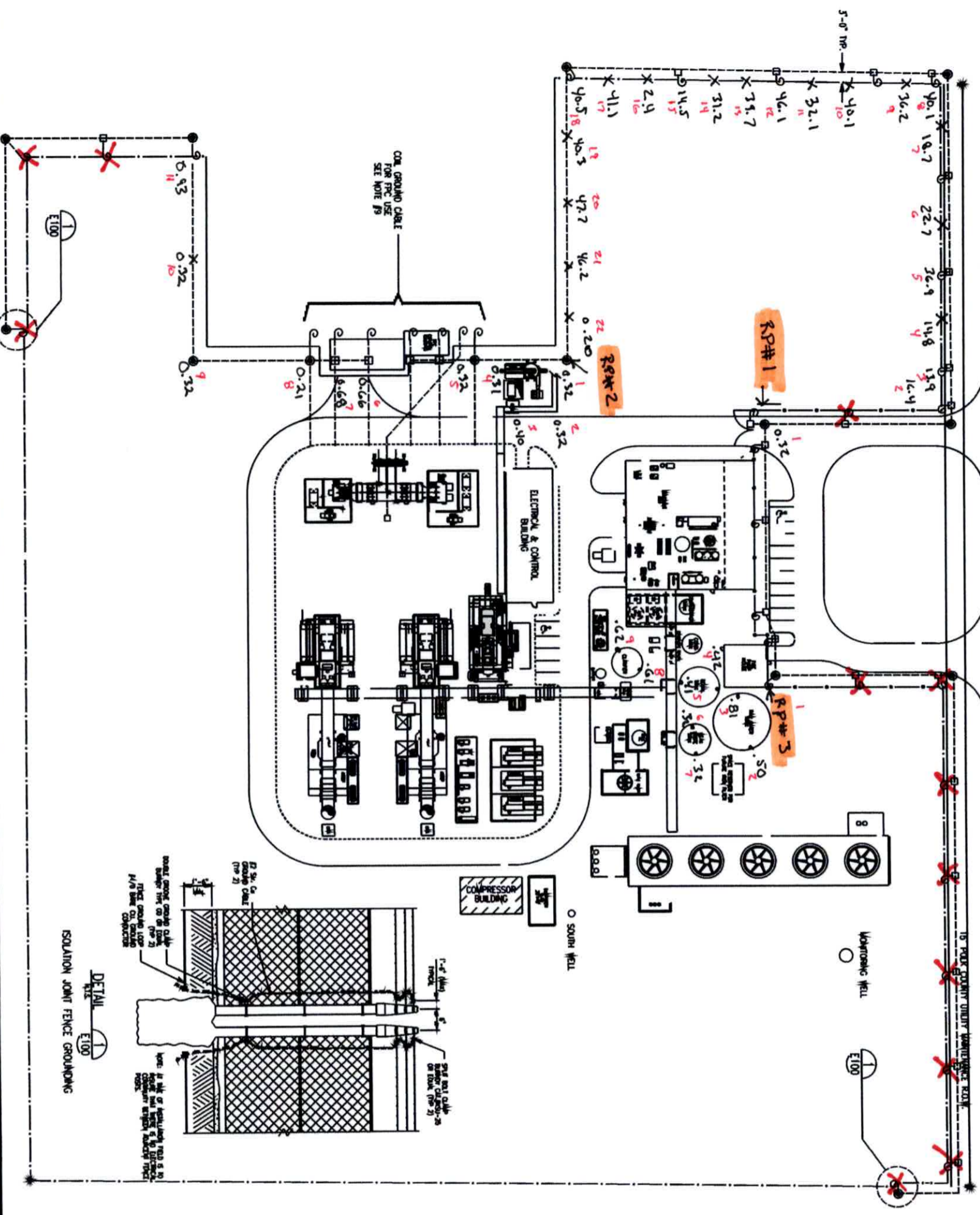

GENERAL LIGHTING NOTES:

1. FOR UNDERGROUND GROUNDING DETAILS SEE SPECIFICATION 2005 206.1 ELECTRICAL INSTALLATION.
2. GROUNDING CONDUCTORS FOR UNDERGROUND INSTALLATION SHALL BE 4/0 AWG SHORT DRAIN COPPER CABLE.
3. UNDERGROUND GROUNDING CONDUCTORS SHALL BE BURIED A MINIMUM 1'-6" BELOW FINISH GRADE. GROUNDING ELECTRODES SHALL BE BURIED A MINIMUM OF 1'-6" BELOW FINISH GRADE.
4. GROUNDING ELECTRODES SHALL BE 3/4" x 10' MINIMUM COPPER CLAD GROUND ROD.
5. A MINIMUM 15' OF CABLE SHALL BE INSTALLED ABOVE FINISH GRADE AT EACH POINT OF EQUIPMENT LOCATION. CABLE SHALL BE CUT TO FIT AT THE TIME OF CONNECTION.
6. GROUNDING CONDUCTORS SHALL NOT PENETRATE CONTAINMENT AREA WALLS OR FLOOR SLABS.
7. GROUNDING CONDUCTORS SHALL BE INSTALLED IN PVC CONDUIT WHERE CABLE PENETRATES FLOOR SLABS, EXPOSED PLUMBING, OR RUN LENGTHS EXCEEDING 5' ABOVEGROUND.
8. GROUNDING CONDUCTORS RUN WITH U/G DUCT BAYS SHALL BE SUBMERGED IN PVC BESIDE CONDUIT AT THE END OF EACH DUCT RUN.
9. GROUNDING CONDUCTORS ENTERING THE ORT TRAPEZOIDAL VARD SHALL BE TERMINATED BY MECHANICAL CONNECTION AS SHOWN ON DWG. 2005 E101-1 FOR TESTING.
10. SEE DWG. 2005 E101-2 FOR FENCE GROUNDING DETAIL.

- DENOTES CABLE TO CHIEF CONNECTION
 ● DENOTES GROUND ROD
 ○ DENOTES CABLE TO GROUND ROD CONNECTION
 ○ DENOTES 15' PERIM. UNDERGROUND 4/0 AWG SHORT DRAIN COPPER CABLE
 ○ DENOTES 4/0 AWG SHORT DRAIN COPPER CABLE
- 2005 E101 TRAPEZOIDAL VARD GROUNDING PLAN
 2005 E102 ELEC. RM. AIR HANDLER GROUNDING PLAN
 2005 E103 SITE GROUNDING PLAN
 2005 E104 WARD'S CRYS. AREA GROUNDING PLAN
 2005 E105 COOLING TOWER GROUNDING PLAN
 2005 E106 CHILLER, GAS COMP. BLDG. GROUNDING PLAN
 2005 E107 PLANT SERVICE BLDG. GROUNDING PLAN
 2005 E108 PLANT SERVICE BLDG. GROUNDING PLAN
 2005 E109 PLANT SERVICE BLDG. GROUNDING PLAN
 2005 E110 PLANT SERVICE BLDG. GROUNDING PLAN
 2005 E111 PLANT SERVICE BLDG. GROUNDING PLAN
 2005 E112 PLANT SERVICE BLDG. GROUNDING PLAN
 2005 E113 PLANT SERVICE BLDG. GROUNDING PLAN
 2005 E114 PLANT SERVICE BLDG. GROUNDING PLAN
 2005 E115 PLANT SERVICE BLDG. GROUNDING PLAN
 2005 E116 PLANT SERVICE BLDG. GROUNDING PLAN
 2005 E117 PLANT SERVICE BLDG. GROUNDING PLAN
 2005 E118 PLANT SERVICE BLDG. GROUNDING PLAN
 2005 E119 PLANT SERVICE BLDG. GROUNDING PLAN
 2005 E120 PLANT SERVICE BLDG. GROUNDING PLAN
 2005 E121 PLANT SERVICE BLDG. GROUNDING PLAN
 2005 E122 PLANT SERVICE BLDG. GROUNDING PLAN
 2005 E123 PLANT SERVICE BLDG. GROUNDING PLAN
 2005 E124 PLANT SERVICE BLDG. GROUNDING PLAN
 2005 E125 PLANT SERVICE BLDG. GROUNDING PLAN
 2005 E126 PLANT SERVICE BLDG. GROUNDING PLAN
 2005 E127 PLANT SERVICE BLDG. GROUNDING PLAN
 2005 E128 PLANT SERVICE BLDG. GROUNDING PLAN
 2005 E129 PLANT SERVICE BLDG. GROUNDING PLAN
 2005 E130 PLANT SERVICE BLDG. GROUNDING PLAN
 2005 E131 PLANT SERVICE BLDG. GROUNDING PLAN
 2005 E132 PLANT SERVICE BLDG. GROUNDING PLAN
 2005 E133 PLANT SERVICE BLDG. GROUNDING PLAN
 2005 E134 PLANT SERVICE BLDG. GROUNDING PLAN
 2005 E135 PLANT SERVICE BLDG. GROUNDING PLAN
 2005 E136 PLANT SERVICE BLDG. GROUNDING PLAN
 2005 E137 PLANT SERVICE BLDG. GROUNDING PLAN
 2005 E138 PLANT SERVICE BLDG. GROUNDING PLAN
 2005 E139 PLANT SERVICE BLDG. GROUNDING PLAN
 2005 E140 PLANT SERVICE BLDG. GROUNDING PLAN
 2005 E141 PLANT SERVICE BLDG. GROUNDING PLAN
 2005 E142 PLANT SERVICE BLDG. GROUNDING PLAN
 2005 E143 PLANT SERVICE BLDG. GROUNDING PLAN
 2005 E144 PLANT SERVICE BLDG. GROUNDING PLAN
 2005 E145 PLANT SERVICE BLDG. GROUNDING PLAN
 2005 E146 PLANT SERVICE BLDG. GROUNDING PLAN
 2005 E147 PLANT SERVICE BLDG. GROUNDING PLAN
 2005 E148 PLANT SERVICE BLDG. GROUNDING PLAN
 2005 E149 PLANT SERVICE BLDG. GROUNDING PLAN
 2005 E150 PLANT SERVICE BLDG. GROUNDING PLAN
 2005 E151 PLANT SERVICE BLDG. GROUNDING PLAN
 2005 E152 PLANT SERVICE BLDG. GROUNDING PLAN
 2005 E153 PLANT SERVICE BLDG. GROUNDING PLAN
 2005 E154 PLANT SERVICE BLDG. GROUNDING PLAN
 2005 E155 PLANT SERVICE BLDG. GROUNDING PLAN
 2005 E156 PLANT SERVICE BLDG. GROUNDING PLAN
 2005 E157 PLANT SERVICE BLDG. GROUNDING PLAN
 2005 E158 PLANT SERVICE BLDG. GROUNDING PLAN
 2005 E159 PLANT SERVICE BLDG. GROUNDING PLAN
 2005 E160 PLANT SERVICE BLDG. GROUNDING PLAN
 2005 E161 PLANT SERVICE BLDG. GROUNDING PLAN
 2005 E162 PLANT SERVICE BLDG. GROUNDING PLAN
 2005 E163 PLANT SERVICE BLDG. GROUNDING PLAN
 2005 E164 PLANT SERVICE BLDG. GROUNDING PLAN
 2005 E165 PLANT SERVICE BLDG. GROUNDING PLAN
 2005 E166 PLANT SERVICE BLDG. GROUNDING PLAN
 2005 E167 PLANT SERVICE BLDG. GROUNDING PLAN
 2005 E168 PLANT SERVICE BLDG. GROUNDING PLAN
 2005 E169 PLANT SERVICE BLDG. GROUNDING PLAN
 2005 E170 PLANT SERVICE BLDG. GROUNDING PLAN
 2005 E171 PLANT SERVICE BLDG. GROUNDING PLAN
 2005 E172 PLANT SERVICE BLDG. GROUNDING PLAN
 2005 E173 PLANT SERVICE BLDG. GROUNDING PLAN
 2005 E174 PLANT SERVICE BLDG. GROUNDING PLAN
 2005 E175 PLANT SERVICE BLDG. GROUNDING PLAN
 2005 E176 PLANT SERVICE BLDG. GROUNDING PLAN
 2005 E177 PLANT SERVICE BLDG. GROUNDING PLAN
 2005 E178 PLANT SERVICE BLDG. GROUNDING PLAN
 2005 E179 PLANT SERVICE BLDG. GROUNDING PLAN
 2005 E180 PLANT SERVICE BLDG. GROUNDING PLAN
 2005 E181 PLANT SERVICE BLDG. GROUNDING PLAN
 2005 E182 PLANT SERVICE BLDG. GROUNDING PLAN
 2005 E183 PLANT SERVICE BLDG. GROUNDING PLAN
 2005 E184 PLANT SERVICE BLDG. GROUNDING PLAN
 2005 E185 PLANT SERVICE BLDG. GROUNDING PLAN
 2005 E186 PLANT SERVICE BLDG. GROUNDING PLAN
 2005 E187 PLANT SERVICE BLDG. GROUNDING PLAN
 2005 E188 PLANT SERVICE BLDG. GROUNDING PLAN
 2005 E189 PLANT SERVICE BLDG. GROUNDING PLAN
 2005 E190 PLANT SERVICE BLDG. GROUNDING PLAN
 2005 E191 PLANT SERVICE BLDG. GROUNDING PLAN
 2005 E192 PLANT SERVICE BLDG. GROUNDING PLAN
 2005 E193 PLANT SERVICE BLDG. GROUNDING PLAN
 2005 E194 PLANT SERVICE BLDG. GROUNDING PLAN
 2005 E195 PLANT SERVICE BLDG. GROUNDING PLAN
 2005 E196 PLANT SERVICE BLDG. GROUNDING PLAN
 2005 E197 PLANT SERVICE BLDG. GROUNDING PLAN
 2005 E198 PLANT SERVICE BLDG. GROUNDING PLAN
 2005 E199 PLANT SERVICE BLDG. GROUNDING PLAN
 2005 E200 PLANT SERVICE BLDG. GROUNDING PLAN

NO.	DATE	DESCRIPTION	BY	CHECKED	APPROVED	DATE
1	7/21	AS-BUILT	OSC			
2	7/25	AS-BUILT	OSC			
3	7/28	AS-BUILT	OSC			
4						
5						

ZURN NATIONAL ENERGY PRODUCTION CORPORATION

NEPCO

ENGINEERED BY: S. WELSH
 SCALE: 1" = 40'
 DATE: 1-11-04
 THIS DRAWING IS THE PROPERTY OF ZURN/NEPCO AND IS NOT TO BE USED IN ANY MANNER WITHOUT THE WRITTEN PERMISSION AND IS TO BE RETURNED UPON REQUEST.

ORANGE COGENERATION FACILITY
 ORANGE COGENERATION UP
 BARTON, FLORIDA

SITE GROUNDING PLAN

DWG. NO. 2055 E100

REV A

LEGEND:

X - Missing ground



MATCH LINE SEE DWG. 2055 E102

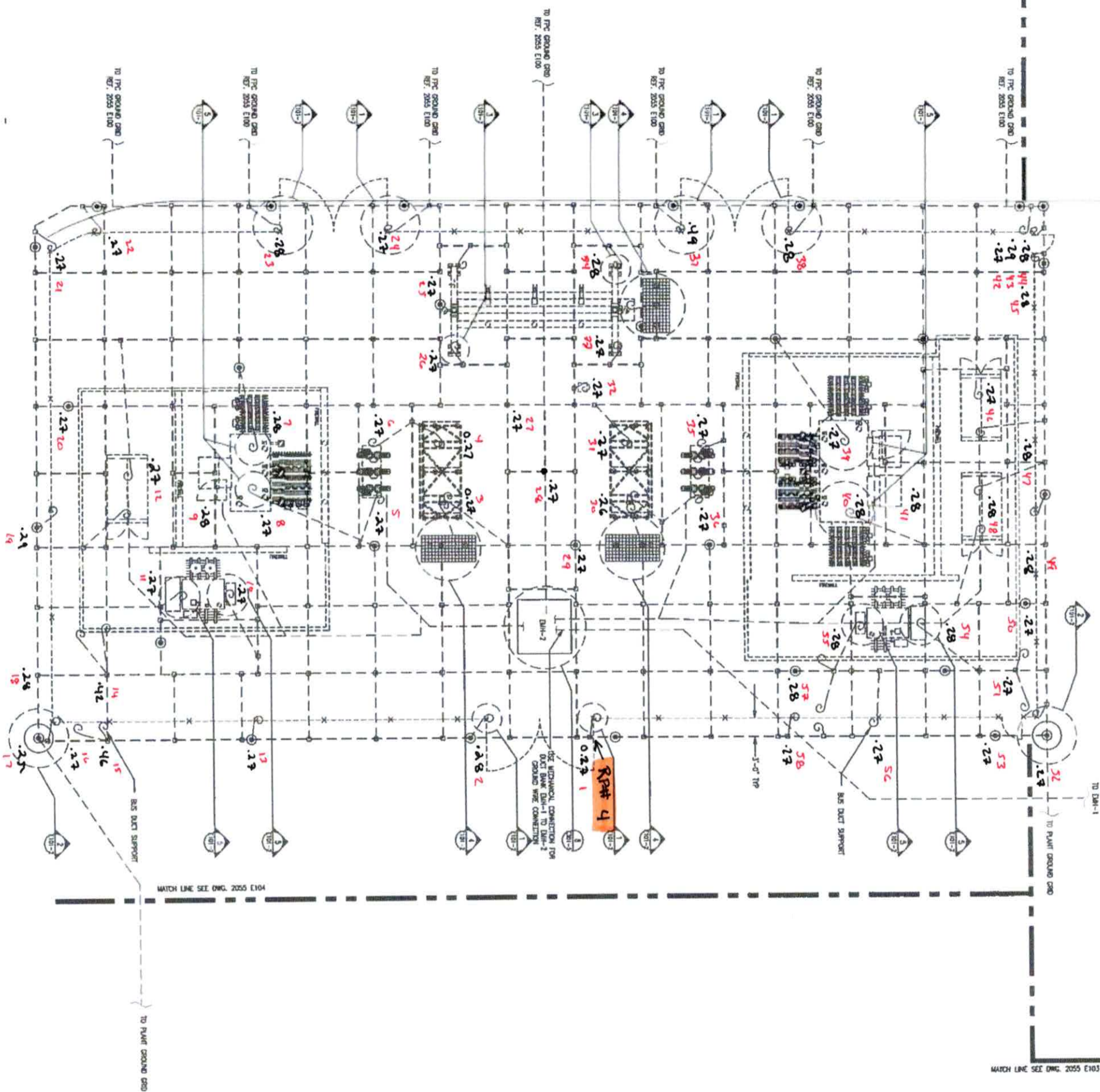

MATCH LINE SEE DWG. 2055 E104

TO PLANT GROUND CABLE

GENERAL NOTES:

1. FOR UNDERGROUND GROUNDING DETAILS SEE SPECIFICATION 2055 206.1 ELECTRICAL INSTALLATION.
 2. GROUNDING CONDUCTORS FOR UNDERGROUND INSTALLATION SHALL BE 4/GAWG SOFT DRAWN COPPER CABLE.
 3. UNDERGROUND GROUNDING CONDUCTORS SHALL BE BURIED A MINIMUM 1'-6" BELOW FINISH GRADE. GROUNDING ELECTRODES SHALL BE DRIVEN A MINIMUM OF 1'-6" BELOW FINISH GRADE.
 4. GROUNDING ELECTRODES FOR TRANSFORMER YARD AREA SHALL BE 3/4" X 100' MINIMUM, COPPER CLAD GROUND ROD.
- | BILL OF MATERIAL (GROUND RODS ONLY) | |
|-------------------------------------|------------------------------------|
| ITEM | DESCRIPTION |
| 1 | 3/4" X 100' COPPER CLAD GROUND ROD |
| 2 | 3/4" X 100' COPPER CLAD GROUND ROD |
| 3 | 3/4" X 100' COPPER CLAD GROUND ROD |
| 4 | 3/4" X 100' COPPER CLAD GROUND ROD |
| 5 | 3/4" X 100' COPPER CLAD GROUND ROD |
5. A MINIMUM 15' OF CABLE SHALL BE INSTALLED ABOVE FINISH GRADE AT EACH PITING OR EQUIPMENT LOCATION. CABLE SHALL BE CUT TO FIT AT THE TIME OF CONNECTION.
 6. GROUNDING CONDUCTORS SHALL NOT PENETRATE CONTAINMENT AREA WALLS OR FLOOR SLABS. SEE DETAIL 5" ON DWG 2055 E101-2.
 7. GROUNDING CONDUCTORS SHALL BE INSTALLED IN PVC CONDUIT WHERE CABLE PENETRATES FLOOR SLABS, EQUIPMENT PADS, OR RUM LENGTHS EXCEEDING 3' ABOVEGROUND.
 8. GROUNDING CONDUCTORS RUN WITH U/G DUCT BANKS SHALL BE STUBBED UP IN PVC BESIDE CONDUIT AT THE END OF EACH DUCT RUN.
 9. FIELD SHALL PROVIDE PERMITS & BUS DUCT SUPPORTS.
- DENOTES CABLE TO CABLE CONNECTION
 - DENOTES 100'-0" GROUND ROD
 - ⊖ DENOTES CABLE TO GROUND ROD CONNECTION
 - ⊕ DENOTES 15' PITING (ABOVEGROUND)
 - ⊗ DENOTES 4/0 SOFT DRAWN COPPER CABLE
 - DENOTES 4/GAWG SOFT DRAWN COPPER CABLE

REFERENCES:

- 2055 E16 UNDERGROUND KEY PLAN
- 2055 E100 SITE GROUNDING PLAN
- 2055 E102 ELECT. BUS, AIR, BOILER GROUNDING PLAN
- 2055 E103 SITE AREA GROUNDING PLAN
- 2055 E104 HRS/S, GTS'S AREA GROUNDING PLAN
- 2055 E301 TRANSFORMER YARD U/G BACKWALK PLAN

REVISION	DATE	DESCRIPTION	BY	CHECKED	APPROVED	PROJ. ENG.	APPROVED	PROJ. MGR./ESTIMATING
Δ	7/21/95	AS-BUILT	DISC					
Δ	4/27/94	ISSUED FOR CONSTRUCTION	DISC	GLF	LAD	WKG	MR	



ORANGE COGENERATION FACILITY

ORANGE COGENERATION LP
 BAYTON, FLORIDA

DWG. NO. 2055 E101-1

REV

000 FILE: C35E101S1.DWG



A B C D E F

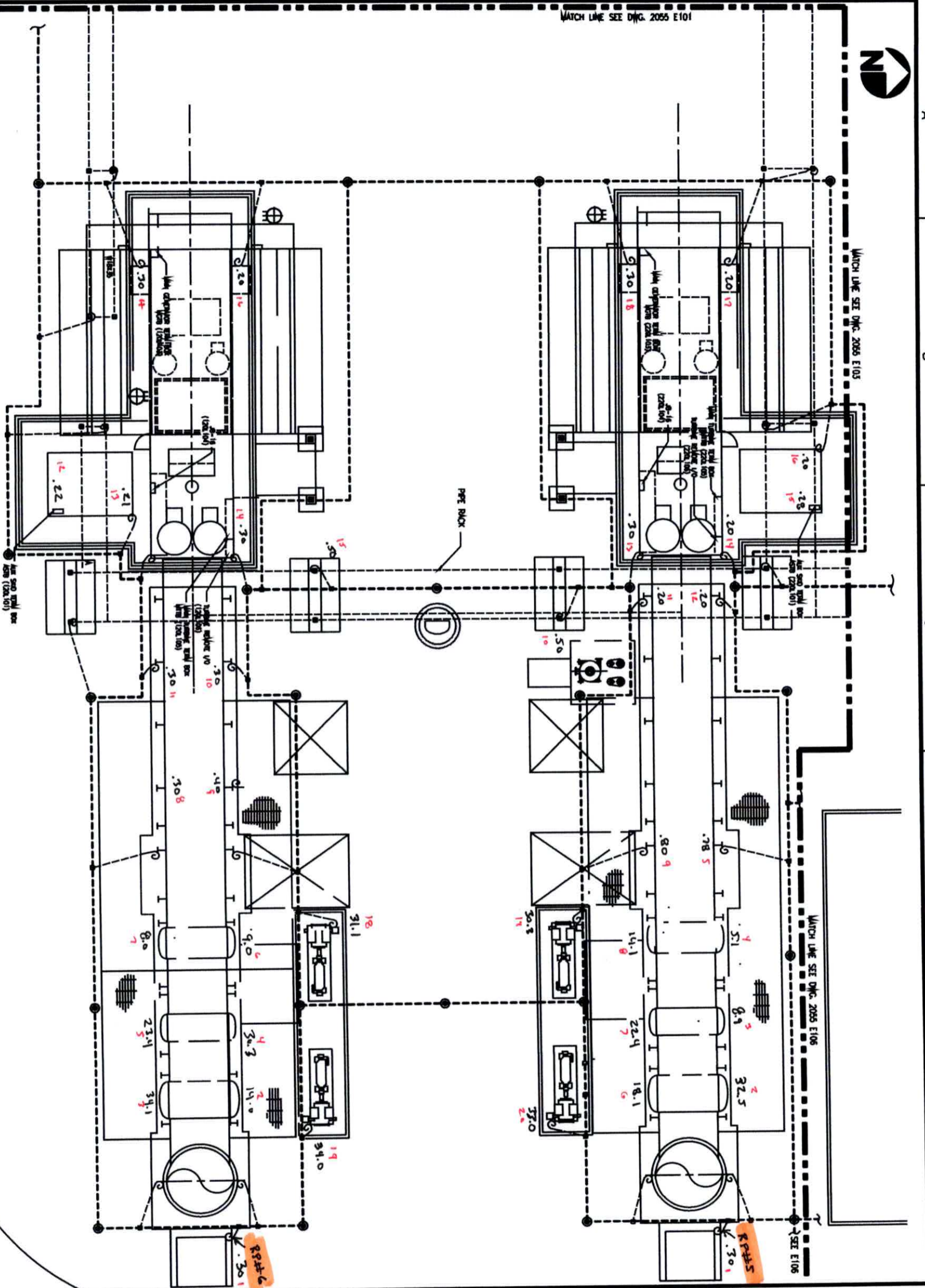

GENERAL NOTES:

1. FOR UNDERGROUND GROUNDING DETAILS SEE SPECIFICATION 2005 206.1 ELECTRICAL INSTALLATION
2. GROUNDING CONDUCTORS FOR UNDERGROUND INSTALLATION SHALL BE 4/0MIL SORT DRAHM COPPER CABLE.
3. UNDERGROUND GROUNDING CONDUCTORS SHALL BE BURIED AT LEAST 18" BELOW FRESH GRADE. GROUNDING ELECTRODES SHALL BE BENTON A MINIMUM OF 18" BELOW FRESH GRADE.
4. GROUNDING ELECTRODES SHALL BE 3/4" x 10' UNPLATED COPPER CLAD GROUND ROD.
5. A MINIMUM 15' OF CABLE SHALL BE INSTALLED ABOVE THE GROUND AT EACH POINT OF EQUIPMENT LOCATION. CABLE SHALL BE CUT TO FIT AT THE TIME OF CONNECTION.
6. GROUNDING CONDUCTORS SHALL NOT PERMEATE CONDUIT-MENT AREA PIPES OR FLOOR SLABS.
7. GROUNDING CONDUCTORS SHALL BE INSTALLED IN PVC CONDUIT WHERE CABLE PENETRATES FLOOR SLABS, EQUIPMENT PANS, OR RUN LENGTHS EXCEEDING 3' ABOVEGROUND.
8. GROUNDING CONDUCTORS RUN WITH U/G DUCT BANKS SHALL BE STUCCOED UP IN PVC BESIDE CONDUIT AT THE END OF EACH DUCT BANK.

- DENOTES CABLE TO CABLE CONNECTION
- DENOTES GROUND ROD
- ◐ DENOTES CABLE TO GROUND ROD CONNECTION
- ◑ DENOTES 18" PFCM (ABSORBER) 4/0MIL SORT DRAHM COPPER CABLE
- DENOTES 4/0MIL SORT DRAHM COPPER CABLE

REFERENCES:

- 2005 E16 ELECTRICAL U/G & LIFTING KEY PLAN
- 2005 E101 TRANSFORMER VARY GROUNDING PLAN
- 2005 E103 SITE AREA GROUNDING PLAN
- 2005 E106 CHILLER GAS COND. BLDG. GROUNDING PLAN

NO.	REVISION	DESCRIPTION	BY	CHECKED	DATE
1					
2					
3					
4					
5					



ORANGE COGENERATION FACILITY
 Orange Cogeneration LP
 Orange, Florida

GROUNDING PLAN
 HRSG/GTG AREA
 2055 E104
 DATE: 1-15-04
 SCALE: 1/8" = 1'-0"



A B C D E F

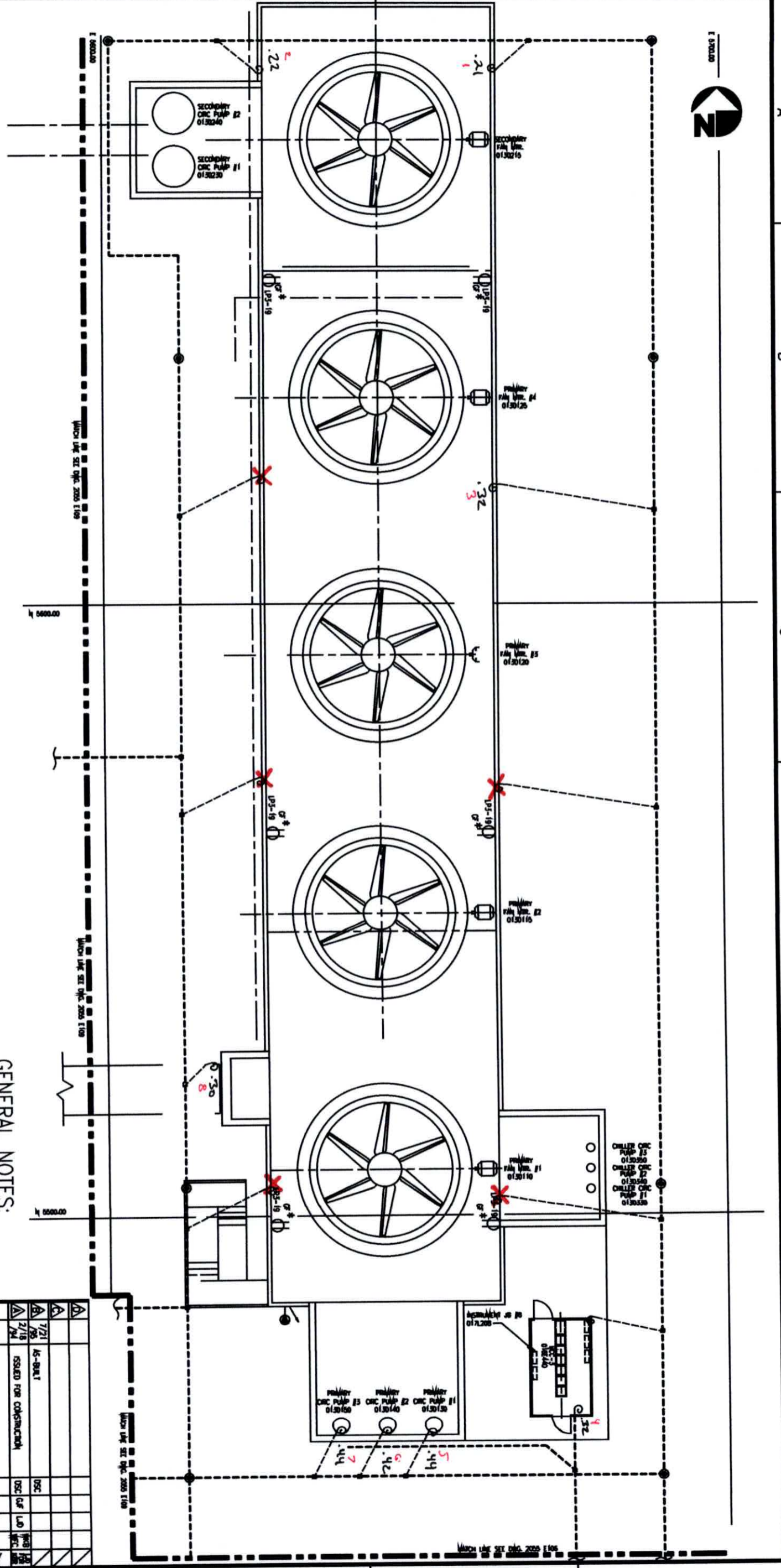

X - missing strands

9. GROUNDING CONDUCTORS AT COOLING TOWER SHALL BE COILED FOR CONNECTION TO LIGHTNING PROTECTION SYSTEM.
7. GROUNDING CONDUCTORS SHALL BE INSTALLED IN PVC CONDUIT WHERE CABLE PENETRATES FLOOR SLABS, EQUIPMENT PADS, OR RUN LENGTHS EXCEEDING 3' ABOVEGROUND.
8. GROUNDING CONDUCTORS RUN WITH U/G DUCT BUNDLES SHALL BE STRAPPED UP IN PVC BESIDE CONDUIT AT THE END OF EACH DUCT BANK.

REFERENCES:

- 2005 E106 ELECTRICAL U/G & LIGHTNING KEY PLAN
- 2005 E106 CHILLER GAS CONDENSING PLAN
- 2005 E109 ZERO WASTE AREA GROUNDING PLAN

- DENOTES CABLE TO CABLE CONNECTION
- DENOTES GROUND ROD
- DENOTES CABLE TO GROUND ROD CONNECTION
- DENOTES 15' PIGTAIL (ABOVEGROUND)
- DENOTES 4/0AWG SOFT DRAWN COPPER CABLE
- DENOTES 4/0AWG SOFT DRAWN COPPER CABLE

GENERAL NOTES:

- FOR UNDERGROUND GROUNDING DETAILS SEE SPECIFICATION 2005 206.1 ELECTRICAL INSTALLATION.
- GROUNDING CONDUCTORS FOR UNDERGROUND INSTALLATION SHALL BE 4/0AWG SOFT DRAWN COPPER CABLE.
- UNDERGROUND GROUNDING CONDUCTORS SHALL BE BURRED A MINIMUM 1'-6" BELOW FINISH GRADE. GROUNDING ELECTRODES SHALL BE BURRED A MINIMUM OF 6" BELOW FINISH GRADE.
- GROUNDING ELECTRODES SHALL BE 3/4" x 10' MINIMUM COPPER CLAD GROUND ROD.
- A MINIMUM 15' OF CABLE SHALL BE INSTALLED ABOVE FINISH GRADE AT EACH PIGTAIL OR EQUIPMENT LOCATION. CABLE SHALL BE CUT TO FIT AT THE TIME OF CONNECTION.
- GROUNDING CONDUCTORS SHALL NOT PENETRATE CONTAINMENT AREA WALLS OR FLOOR SLABS.

DATE	DESCRIPTION	BY	CHECKED	APPROVED
7/21/05	ISSUED FOR CONSTRUCTION	OSG	CAF	LD
7/18/05				
7/14/05				



NATIONAL ENERGY PRODUCTION CORPORATION
ORANGE COGENERATION FACILITY
GROUNDING PLAN
BARTON, FLORIDA
COOLING TOWER AREA

SCALE:	DATE:	DESIGNED BY:	CHECKED BY:
1/8" = 1'-0"	1-12-05	G. HALL	
THIS DRAWING IS THE PROPERTY OF ZURN/NEPCO AND IS NOT TO BE USED IN ANY WAY WITHOUT PERMISSION TO THEIR EMPLOYEES AND IS TO BE RETURNED UPON REQUEST.			
DATE:	DESCRIPTION:	BY:	REV:
2005 E105	GROUNDING PLAN		
2005 E105	COOLING TOWER AREA		

REV 27.9

A B C D E F

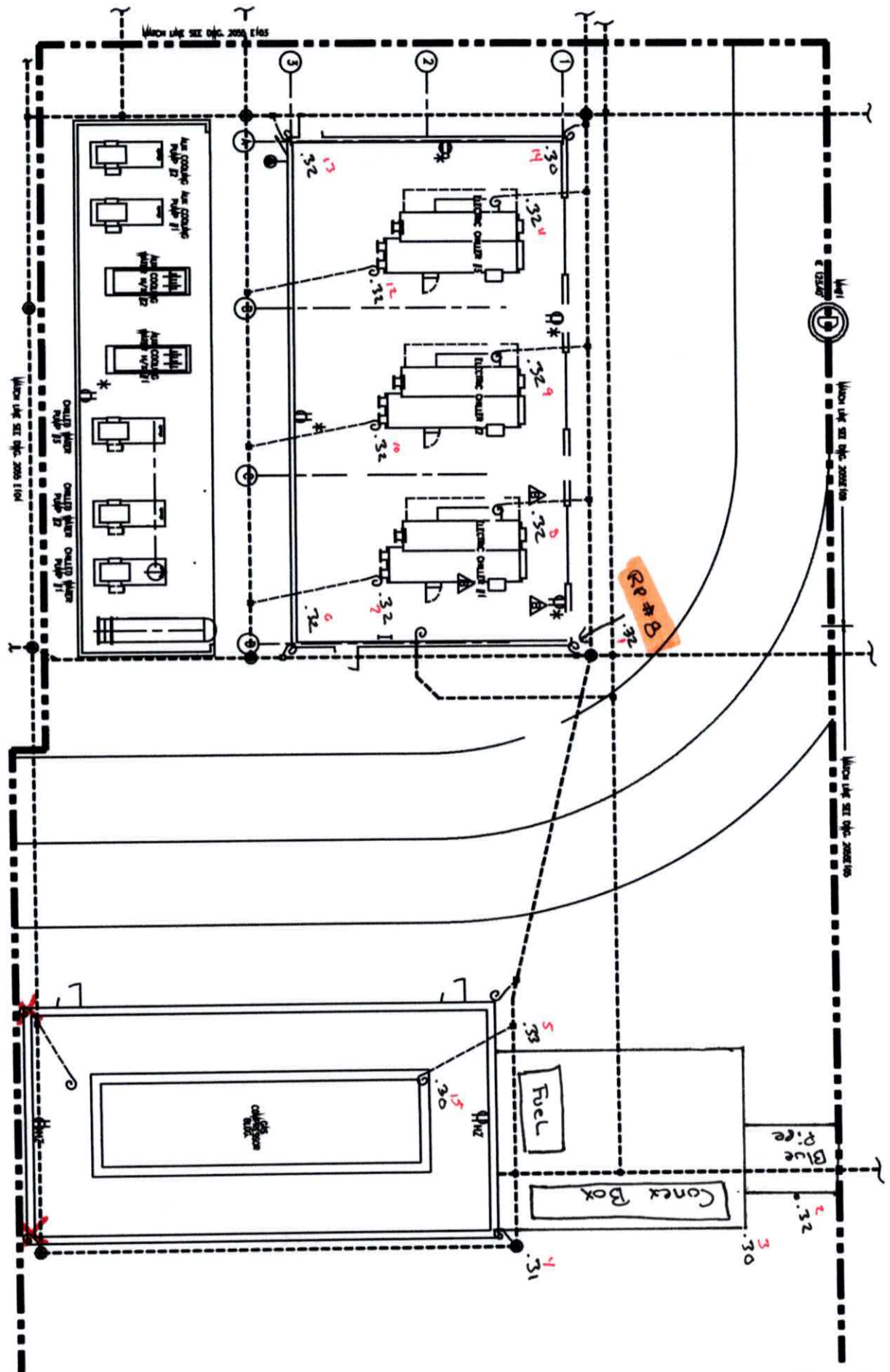

GENERAL NOTES:

1. FOR UNDERGROUND GROUNDING RITLS SEE SPECIFICATION 2005 206.1 ELECTRICAL INSTALLATION.
2. GROUNDING CONDUCTORS FOR UNDERGROUND INSTALLATION SHALL BE 4/0AWG SORT BROWN COPPER CABLE.
3. UNDERGROUND GROUNDING CONDUCTORS SHALL BE BARED 18" MINIMUM AT EACH POINT OF EQUIPMENT LOCATION. ELECTRODES SHALL BE BARED A MINIMUM OF 18" BELOW FRESH GRADE.
4. GROUNDING ELECTRODES SHALL BE 3/4" x 10' MINIMUM COPPER CLAD GROUND ROD.
5. A MINIMUM 15' OF CABLE SHALL BE INSTALLED ABOVE FRESH GRADE AT EACH POINT OF EQUIPMENT LOCATION. CABLE SHALL BE CUT TO FIT AT THE TIME OF CONNECTION.
6. GROUNDING CONDUCTORS SHALL NOT PENETRATE CONCRETE-LEVEL AREA WALLS OR FLOOR SLABS.
7. GROUNDING CONDUCTORS SHALL BE INSTALLED IN PVC CONDUIT WHERE CABLE PENETRATES FLOOR SLABS, ELEVATED PLATS, OR RUN LENGTHS EXCEEDING 3' ABOVEGROUND.
8. GROUNDING CONDUCTORS RUN WITH V/G DUCT BUNDLES SHALL BE STRAPPED UP IN PVC ESSORE CONDUIT AT THE END OF EACH DUCT RUN.

- DEPOINTS CABLE TO CABLE CONNECTION
- DEPOINTS GROUND ROD
- DEPOINTS CABLE TO GROUND ROD CONNECTION
- DEPOINTS 15' PERCH. ABOVEGROUND
- 4/0AWG SORT BROWN COPPER CABLE
- DEPOINTS 4/0AWG SORT BROWN COPPER CABLE

REFERENCE DRAWINGS:

- 2005 E16 ELECTRICAL V/G & LEADING KEY PLAN
- 2005 E104 HESS'S GAS AREA GROUNDING PLAN
- 2005 E106 CHILLER GAS COMP. BLDG. GROUNDING PLAN
- 2005 E107 PAINT SERVICES BLDG. GROUNDING PLAN
- 2005 E109 WASTE AREA GROUNDING PLAN
- 2005 E306 GAS COMP. CHILLER AREA V/G RECEPTOR PLAN

NO.	DATE	DESCRIPTION	BY	CHKD.	APP'D.
1	7/21	AS-BUILT			
2	7/19	ISSUED FOR CONSTRUCTION	OSC	CAF	LAB
3	7/19				
4					
5					

X - missing grounds

ZURN NATIONAL ENERGY PRODUCTION CORPORATION

NEPCO

DATE: 1-27-04
 SCALE: 1/8"=1'-0"
 THIS DRAWING IS THE PROPERTY OF ZURN/NEPCO AND IS NOT TO BE USED BY ANY OTHER PERSONS TO THEIR INTERESTS AND IS TO BE RETURNED UPON REQUEST.

ORANGE COGENERATION FACILITY
 ORANGE COGENERATION LP
 BENTON, FLORIDA

GROUNDING PLAN
 GAS COMPRESSOR BLDG & CHILLER AREA

DWG. NO. 2055 E106

REV. 1

DATE: 02/28/04



Orange Cogen

Test Reports

Ground Grid

Job #OCFL2310067



Empowering Electrical Infrastructure
for a Sustainable Future



Testing and Commissioning Services

6625 Network Way, Indianapolis, IN 46278

www.hva-inc.com/pc-field-services/

Orange Cogen
1901 S. Clear Springs Rd
Bartow, FL 33830

David Courson,

We are pleased to present the field test reports for the ground grid conducted by High Voltage Advanced. This report highlights the comprehensive analysis and results obtained during the field-testing phase, providing valuable insights into the performance and reliability of your electrical system under evaluation.

At HVA, we strive to deliver exceptional products and services, backed by rigorous testing and analysis. We understand the significance of the field test results in evaluating the effectiveness and safety of your electrical system. The information contained in this report is intended to provide you with a detailed overview of the performance characteristics, environmental considerations, and any observed issues during the testing phase.

Key Sections of the Field Test Report:

- **Equipment Tested:** all equipment that was tested during the field-testing phase.
- **Scope of Work:** Detailed explanation of the goals and objectives of the field test.
- **Observations and Recommendations:** Identification of any observed issues or challenges, accompanied by recommendations for improvement or further investigations, if necessary.
- **Results:** In-depth examination of the obtained data, including test data sheets, system behavior, and any deviations from expected outcomes at the time of testing.

We understand that your valuable feedback is crucial in our continuous efforts to enhance our offerings. Therefore, we encourage you to review the field test report thoroughly and reach out to us with any questions or concerns you may have. Our dedicated team of experts is available to provide further clarification or address any questions you may have.

We sincerely appreciate the opportunity to collaborate with you on this project and remain committed to delivering the highest quality solutions to meet your needs. Should you require any additional information or assistance, please do not hesitate to contact us.

Thank you for your trust and continued partnership.

Sincerely,

Matthew Falchetti

Lead Technician

NICET I #153748

Cell: (863)528-4124

HVA - P&C / Field Services

matt.falchetti@hva-inc.com

www.hva-inc.com/pc-field-services/



Chris Roehm

Field Services Manager

NICET III #152740

Cell: (843)818-8847

HVA - P&C / Field Services

chris.roehm@hva-inc.com

www.hva-inc.com/pc-field-services/





Testing and Commissioning Services

6625 Network Way, Indianapolis, IN 46278

www.hva-inc.com/pc-field-services/

Equipment Tested: Ground Grid

Scope of Work: Point to Point testing

Observations and Recommendations:

Results: Missing ground tails and some bad

connections that need to be fixed.

GROUND RESISTIVITY TEST



CUSTOMER Orange Cogen PAGE _____
 ADDRESS 1901 S. Clear Springs Rd; Bartow FL 33830 DATE 8/3/2023
 OWNER Orange Cogen; 1901 S. Clear Springs Rd; Bartow FL 33830 JOB # OCFL2310067
 SITE Orange Cogen TEST STATUS _____ Pass
 SUBSTATION Ground Grid ASSET ID 2055 E100
 EQUIPMENT 2055 E100 AMBIENT TEMPERATURE 80 °F HUMIDITY 66 %

SOIL TYPE Normal Ground with grass and pavement SOIL CONDITION: DRY DAMP WET

TEST PLOT ID #	METER READING (OHMS)
RP #1	0.32
2	16.4
3	13.9
4	14.8
5	36.9
6	22.7
7	18.7
8	40.1
9	36.2
10	40.1
11	32.1
12	46.1
13	39.7
14	31.2
15	14.5

TEST PLOT ID #	METER READING (OHMS)
16	2.4
17	41.1
18	40.5
19	40.3
20	47.7
21	46.2
22	0.20
RP #2	0.32
2	0.32
3	0.40
4	0.31
5	0.32
6	0.66
7	0.68
8	0.21

TEST PLOT ID #	METER READING (OHMS)
9	0.32
10	0.32
11	0.93
RP #3	0.60
2	0.50
3	0.81
4	0.42
5	0.41
6	0.32
7	0.32
8	0.61
9	0.62

GROUND RESISTIVITY TEST



PAGE _____

COMMENTS:

DEFICIENCIES:

EQUIPMENT USED:

#	Manufacturer	Model	Serial / ID Number	Type	Calibration Date	Calibration Due
1	FLUKE	FLUKE - 87V	38210208	MULTIMETER	1/14/2023	1/14/2024
2	ETCR	ETCR3000C	30530077	EARTH RES. T	1/13/2023	1/13/2024

GROUND RESISTIVITY TEST



CUSTOMER Orange Cogen PAGE _____
 ADDRESS 1901 S. Clear Springs Rd; Bartow FL 33830 DATE 8/3/2023
 OWNER Orange Cogen; 1901 S. Clear Springs Rd; Bartow FL 33830 JOB # OCFL2310067
 SITE Orange Cogen TEST STATUS _____ Pass
 SUBSTATION Ground Grid ASSET ID 2055 E101-1
 EQUIPMENT 2055 E101-1 AMBIENT TEMPERATURE 80 °F HUMIDITY 66 %

SOIL TYPE Normal Ground with grass and pavement SOIL CONDITION: DRY DAMP WET

TEST PLOT ID #	METER READING (OHMS)
RP #4	0.22
2	0.28
3	0.27
4	0.27
5	0.27
6	0.27
7	0.28
8	0.27
9	0.28
10	0.27
11	0.27
12	0.27
13	0.27
14	0.42
15	0.46

TEST PLOT ID #	METER READING (OHMS)
16	0.27
17	0.25
18	0.28
19	0.29
20	0.27
21	0.27
22	0.27
23	0.28
24	0.27
25	0.27
26	0.27
27	0.27
28	0.27
29	0.27
30	0.26

TEST PLOT ID #	METER READING (OHMS)
31	0.27
32	0.27
33	0.27
34	0.28
35	0.27
36	0.27
37	0.49
38	0.28
39	0.27
40	0.28
41	0.28
42	0.27
43	0.29
44	0.28
45	0.28

GROUND RESISTIVITY TEST



PAGE _____

COMMENTS:

DEFICIENCIES:

EQUIPMENT USED

#	Manufacturer	Model	Serial / ID Number	Type	Calibration Date	Calibration Due
1	FLUKE	FLUKE - 87V	38210208	MULTIMETER	1/14/2023	1/14/2024
2	ETCR	ETCR3000C	30530077	EARTH RES. T	1/13/2023	1/13/2024

GROUND RESISTIVITY TEST



CUSTOMER Orange Cogen PAGE _____
 ADDRESS 1901 S. Clear Springs Rd; Bartow FL 33830 DATE 8/3/2023
 OWNER Orange Cogen; 1901 S. Clear Springs Rd; Bartow FL 33830 JOB # OCFL2310067
 SITE Orange Cogen TEST STATUS _____ Pass
 SUBSTATION Ground Grid ASSET ID 2055 E101-1 CONT.
 EQUIPMENT 2055 E101-1 AMBIENT TEMPERATURE 80 °F HUMIDITY 66 %

SOIL TYPE Normal Ground with grass and pavement SOIL CONDITION: DRY DAMP WET

TEST PLOT ID #	METER READING (OHMS)
46	0.27
47	0.28
48	0.28
49	0.28
50	0.27
51	0.27
52	0.27
53	0.27
54	0.28
55	0.28
56	0.27
57	0.28
58	0.27

TEST PLOT ID #	METER READING (OHMS)

TEST PLOT ID #	METER READING (OHMS)

GROUND RESISTIVITY TEST



PAGE _____

COMMENTS:

DEFICIENCIES:

EQUIPMENT USED

#	Manufacturer	Model	Serial / ID Number	Type	Calibration Date	Calibration Due
1	FLUKE	FLUKE - 87V	38210208	MULTIMETER	1/14/2023	1/14/2024
2	ETCR	ETCR3000C	30530077	EARTH RES. T	1/13/2023	1/13/2024

GROUND RESISTIVITY TEST



CUSTOMER Orange Cogen PAGE _____
 ADDRESS 1901 S. Clear Springs Rd; Bartow FL 33830 DATE 8/3/2023
 OWNER Orange Cogen; 1901 S. Clear Springs Rd; Bartow FL 33830 JOB # OCFL2310067
 SITE Orange Cogen TEST STATUS _____ Pass
 SUBSTATION Ground Grid ASSET ID 2055 E104
 EQUIPMENT 2055 E104 AMBIENT TEMPERATURE 80 °F HUMIDITY 66 %

SOIL TYPE Normal Ground with grass and pavement SOIL CONDITION: DRY DAMP WET

TEST PLOT ID #	METER READING (OHMS)
RP #5	0.30
2	32.5
3	8.9
4	5.1
5	0.78
6	18.1
7	22.4
8	14.1
9	0.80
10	0.50
11	0.20
12	0.20
13	0.30
14	0.20
15	0.28

TEST PLOT ID #	METER READING (OHMS)
16	0.20
17	0.20
18	0.30
19	30.3
20	33.0
RP #6	0.30
2	14.0
3	34.1
4	30.3
5	23.4
6	9.0
7	8.0
8	0.30
9	0.40
10	0.30

TEST PLOT ID #	METER READING (OHMS)
11	0.30
12	0.22
13	0.21
14	0.30
15	0.50
16	0.20
17	0.30
18	31.1
19	34.0

GROUND RESISTIVITY TEST



PAGE _____

COMMENTS:

DEFICIENCIES:

EQUIPMENT USED:

#	Manufacturer	Model	Serial / ID Number	Type	Calibration Date	Calibration Due
1	FLUKE	FLUKE - 87V	38210208	MULTIMETER	1/14/2023	1/14/2024
2	ETCR	ETCR3000C	30530077	EARTH RES. T	1/13/2023	1/13/2024

GROUND RESISTIVITY TEST



CUSTOMER Orange Cogen PAGE _____
 ADDRESS 1901 S. Clear Springs Rd; Bartow FL 33830 DATE 8/3/2023
 OWNER Orange Cogen; 1901 S. Clear Springs Rd; Bartow FL 33830 JOB # OCFL2310067
 SITE Orange Cogen TEST STATUS _____ Pass
 SUBSTATION Ground Grid ASSET ID _____ 2055 E105
 EQUIPMENT 2055 E105 AMBIENT TEMPERATURE 80 °F HUMIDITY 66 %

SOIL TYPE _____ Normal Ground with grass and pavement SOIL CONDITION: DRY DAMP WET

TEST PLOT ID #	METER READING (OHMS)
RP #7	0.22
1	0.21
2	0.22
3	0.32
4	0.32
5	0.44
6	0.42
7	0.44
8	0.30

TEST PLOT ID #	METER READING (OHMS)

TEST PLOT ID #	METER READING (OHMS)

GROUND RESISTIVITY TEST



PAGE _____

COMMENTS:

DEFICIENCIES:

EQUIPMENT USED:

#	Manufacturer	Model	Serial / ID Number	Type	Calibration Date	Calibration Due
1	FLUKE	FLUKE - 87V	38210208	MULTIMETER	1/14/2023	1/14/2024
2	ETCR	ETCR3000C	30530077	EARTH RES. T	1/13/2023	1/13/2024

GROUND RESISTIVITY TEST



CUSTOMER Orange Cogen PAGE _____

ADDRESS 1901 S. Clear Springs Rd; Bartow FL 33830 DATE 8/3/2023

OWNER Orange Cogen; 1901 S. Clear Springs Rd; Bartow FL 33830 JOB # OCFL2310067

SITE Orange Cogen TEST STATUS _____ Pass _____

SUBSTATION Ground Grid ASSET ID 2055 E106

EQUIPMENT 2055 E106 AMBIENT TEMPERATURE 80 °F HUMIDITY 66 %

SOIL TYPE Normal Ground with grass and pavement SOIL CONDITION: DRY DAMP WET

TEST PLOT ID #	METER READING (OHMS)
RP #8	0.32
2	0.32
3	0.30
4	0.31
5	0.33
6	0.32
7	0.32
8	0.32
9	0.32
10	0.32
11	0.32
12	0.32
13	0.32
14	0.30
15	0.30

TEST PLOT ID #	METER READING (OHMS)

TEST PLOT ID #	METER READING (OHMS)

TESTED BY: Matthew Falchetti / Andrew Kirk / Chris Weedman

GROUND RESISTIVITY TEST



PAGE _____

COMMENTS:

DEFICIENCIES:

EQUIPMENT USED:

#	Manufacturer	Model	Serial / ID Number	Type	Calibration Date	Calibration Due
1	FLUKE	FLUKE - 87V	38210208	MULTIMETER	1/14/2023	1/14/2024
2	ETCR	ETCR3000C	30530077	EARTH RES. T	1/13/2023	1/13/2024

A B C D E F

CLEAR SPRINGS ROAD

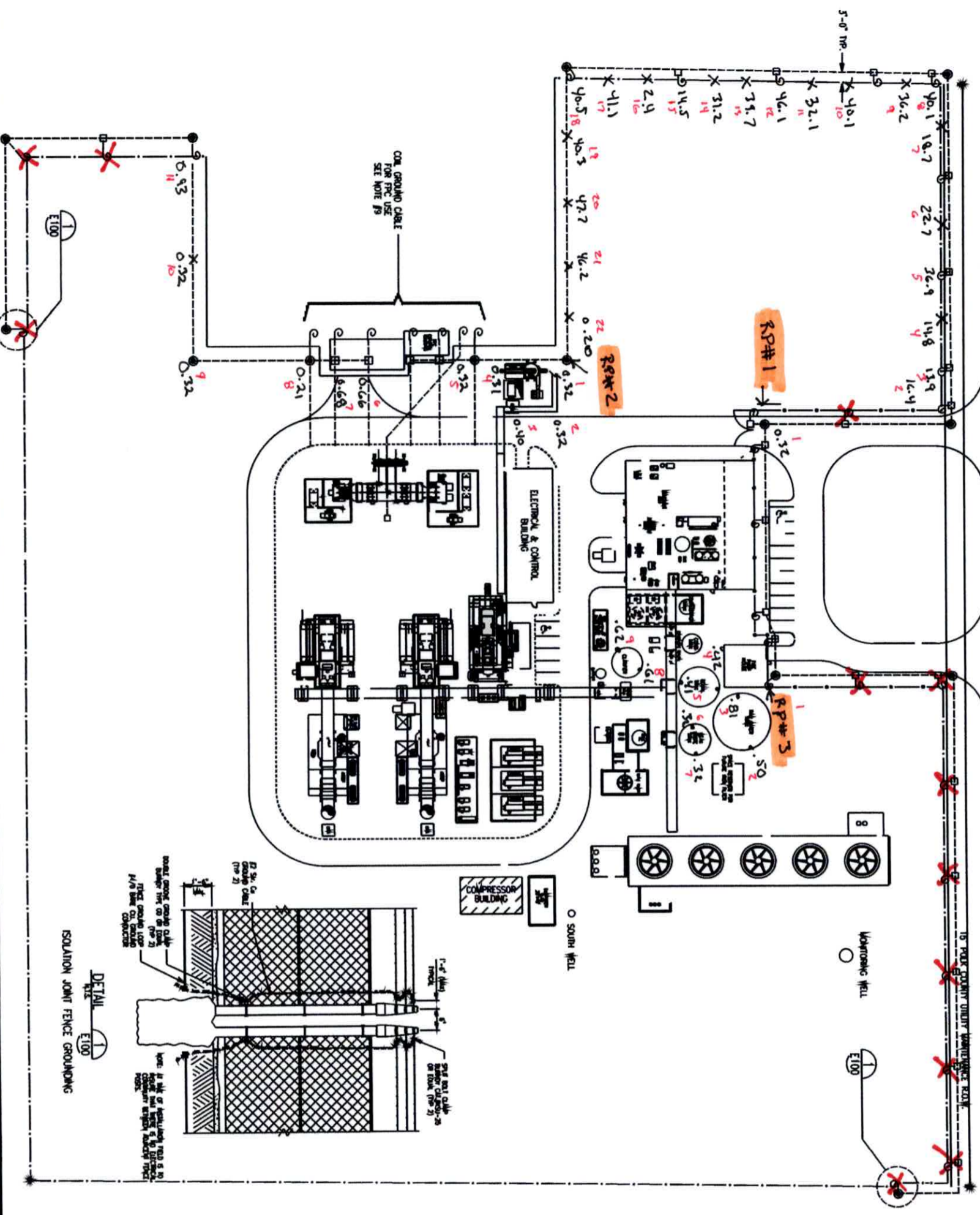

GENERAL LIGHTING NOTES:

1. FOR UNDERGROUND GROUNDING DETAILS SEE SPECIFICATION 2005 206.1 ELECTRICAL INSTALLATION.
2. GROUNDING CONDUCTORS FOR UNDERGROUND INSTALLATION SHALL BE 4/0 AWG SOFT DRAWN COPPER CABLE.
3. UNDERGROUND GROUNDING CONDUCTORS SHALL BE BURIED A MINIMUM 1'-6" BELOW FINISH GRADE. GROUNDING ELECTRODES SHALL BE BURIED A MINIMUM OF 1'-0" BELOW FINISH GRADE.
4. GROUNDING ELECTRODES SHALL BE 3/4" x 10' MINIMUM COPPER CLAD GROUND ROD.
5. A MINIMUM 15' OF CABLE SHALL BE INSTALLED ABOVE FINISH GRADE AT EACH POINT OF EQUIPMENT LOCATION. CABLE SHALL BE CUT TO FIT AT THE TIME OF CONNECTION.
6. GROUNDING CONDUCTORS SHALL NOT PENETRATE CONTAINMENT AREA WALLS OR FLOOR SLABS.
7. GROUNDING CONDUCTORS SHALL BE INSTALLED IN PVC CONDUIT WHERE CABLE PENETRATES FLOOR SLABS, EXPOSED PLUMBING, OR RUN LENGTHS EXCEEDING 5' ABOVEGROUND.
8. GROUNDING CONDUCTORS RUN WITH U/G DUCT BAYS SHALL BE SUBMERGED IN PVC BESIDE CONDUIT AT THE END OF EACH DUCT RUN.
9. GROUNDING CONDUCTORS ENTERING THE ORT TRANSFORMER VARD SHALL BE TERMINATED BY MECHANICAL CONNECTION AS SHOWN ON DWG. 2005 E101-1 FOR TESTING.
10. SEE DWG. 2005 E101-2 FOR FENCE GROUNDING DETAIL.

- DENOTES CABLE TO CABLE CONNECTION
 - DENOTES GROUND ROD
 - DENOTES CABLE TO GROUND ROD CONNECTION
 - DENOTES 15' P.O.L. UNDERGROUND 4/0 AWG SOFT DRAWN COPPER CABLE
 - DENOTES 4/0 AWG SOFT DRAWN COPPER CABLE
- 2005 E101 TRANSFORMER VARD GROUNDING PLAN
 2005 E102 ELECT. RM. AIR BLOWER GROUNDING PLAN
 2005 E103 SITE GROUNDING PLAN
 2005 E104 WARD'S GUY'S AREA GROUNDING PLAN
 2005 E105 COOLING TOWER GROUNDING PLAN
 2005 E106 CHILLER, GAS COMP. BLDG. GROUNDING PLAN
 2005 E107 PLANT SERVICE BLDG. GROUNDING PLAN
 2005 E108 FENCE GROUNDING PLAN
 2005 E109 FENCE GROUNDING PLAN
 2005 E110 FENCE GROUNDING PLAN
 2005 E111 FENCE GROUNDING PLAN
 2005 E112 FENCE GROUNDING PLAN
 2005 E113 FENCE GROUNDING PLAN
 2005 E114 FENCE GROUNDING PLAN
 2005 E115 FENCE GROUNDING PLAN
 2005 E116 FENCE GROUNDING PLAN
 2005 E117 FENCE GROUNDING PLAN
 2005 E118 FENCE GROUNDING PLAN
 2005 E119 FENCE GROUNDING PLAN
 2005 E120 FENCE GROUNDING PLAN

LEGEND:
 X - Missing Ground

NO.	DATE	DESCRIPTION	BY	CHECKED	APPROVED	DATE
1	7/21	AS-BUILT	OSC			
2	7/25	FIELD REV CORRECTIONS	OSC	CAF	LAD	8/11/05
3		DESCRIPTION				

ZURN NATIONAL ENERGY PRODUCTION CORPORATION
NEPCO

DESIGNED BY: S. WEIN
 SCALE: 1" = 40'
 DATE: 1-11-04
 THIS DRAWING IS THE PROPERTY OF ZURN/NEPCO AND IS NOT TO BE USED IN ANY MANNER UNLESS TO THE EXTENT AND TO BE RETURNED UPON REQUEST.

ORANGE COGENERATION FACILITY
 ORANGE COGENERATION LP
 BARTON, FLORIDA

SITE GROUNDING PLAN

DWG. NO. 2055 E100
 REV. A

5



MATCH LINE SEE DWG. 2055 E102

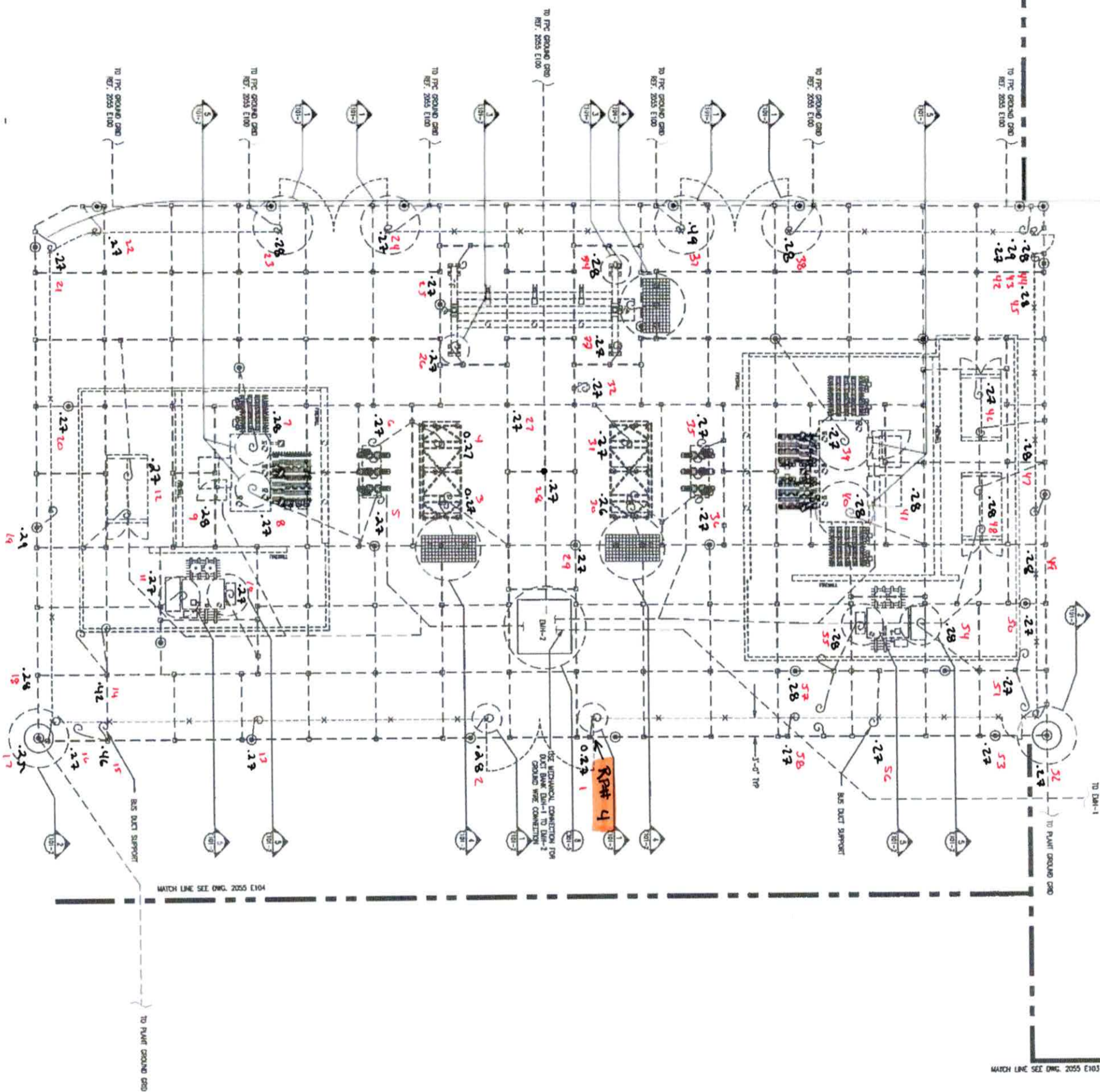

GENERAL NOTES:

1. FOR UNDERGROUND GROUNDING DETAILS SEE SPECIFICATION 2055 206.1 ELECTRICAL INSTALLATION.
 2. GROUNDING CONDUCTORS FOR UNDERGROUND INSTALLATION SHALL BE 4/GAWG SOFT DRAWN COPPER CABLE.
 3. UNDERGROUND GROUNDING CONDUCTORS SHALL BE BURIED A MINIMUM 1'-6" BELOW FINISH GRADE. GROUNDING ELECTRODES SHALL BE DRIVEN A MINIMUM OF 1'-6" BELOW FINISH GRADE.
 4. GROUNDING ELECTRODES FOR TRANSFORMER YARD AREA SHALL BE 3/4" X 100' MINIMUM COPPER CLAD GROUND ROD.
- | BILL OF MATERIAL (GROUND RODS ONLY) | |
|-------------------------------------|------------------------------------|
| ITEM | DESCRIPTION |
| 1 | 3/4" X 100' COPPER CLAD GROUND ROD |
| 2 | 3/4" X 100' COPPER CLAD GROUND ROD |
| 3 | 3/4" X 100' COPPER CLAD GROUND ROD |
| 4 | 3/4" X 100' COPPER CLAD GROUND ROD |
| 5 | 3/4" X 100' COPPER CLAD GROUND ROD |
5. A MINIMUM 15' OF CABLE SHALL BE INSTALLED ABOVE FINISH GRADE AT EACH PITING OR EQUIPMENT LOCATION. CABLE SHALL BE CUT TO FIT AT THE TIME OF CONNECTION.
 6. GROUNDING CONDUCTORS SHALL NOT PENETRATE CONTAINMENT AREA WALLS OR FLOOR SLABS. SEE DETAIL 5" ON DWG 2055 E101-2.
 7. GROUNDING CONDUCTORS SHALL BE INSTALLED IN PVC CONDUIT WHERE CABLE PENETRATES FLOOR SLABS, EQUIPMENT PADS, OR RUM LENGTHS EXCEEDING 3' ABOVEGROUND.
 8. GROUNDING CONDUCTORS RUN WITH U/G DUCT BANKS SHALL BE STUBBED UP IN PVC BESIDE CONDUIT AT THE END OF EACH DUCT RUN.
 9. FIELD SHALL PROVIDE PERMITS & BUS DUCT SUPPORTS.
- DENOTES CABLE TO CABLE CONNECTION
 - DENOTES 100'-0" GROUND ROD
 - ⊙ DENOTES CABLE TO GROUND ROD CONNECTION
 - ⊕ DENOTES 15' PITING (ABOVEGROUND)
 - ⊖ DENOTES 4/GAWG SOFT DRAWN COPPER CABLE
 - ⊗ DENOTES 4/GAWG SOFT DRAWN COPPER CABLE

REFERENCES:

- 2055 E16 UNDERGROUND KEY PLAN
- 2055 E100 SITE GROUNDING PLAN
- 2055 E102 ELECT. BUS DUCT GROUNDING PLAN
- 2055 E103 SITE AREA GROUNDING PLAN
- 2055 E104 HRS/SG'S GTS'S AREA GROUNDING PLAN
- 2055 E301 TRANSFORMER YARD U/G BACKWALK PLAN

REVISION	DATE	DESCRIPTION	BY	CHECKED	APPROVED	PROJ. ENG.	APPROVED	PROJ. MGR./ESTIMATING
Δ	7/21/95	AS-BUILT	DISC					
Δ	4/27/94	ISSUED FOR CONSTRUCTION	DISC	GLF	LAD	WKG	MR	



NATIONAL ENERGY PRODUCTION CORPORATION
 ENGINEERED BY: C. FARVA
 DATE: 1-11-94
 SCALE: 1/8"=1'
 THIS DRAWING IS THE PROPERTY OF ZURN/NEPCO AND IS NOT TO BE USED IN ANY WAY INJURIOUS TO THEIR INTERESTS AND IS TO BE RETURNED UPON REQUEST.

ORANGE COGENERATION FACILITY

ORANGE COGENERATION LP
 BAYTON, FLORIDA

GROUNDING PLAN
 TRANSFORMER YARD
 DWG. NO. 2055 E101-1

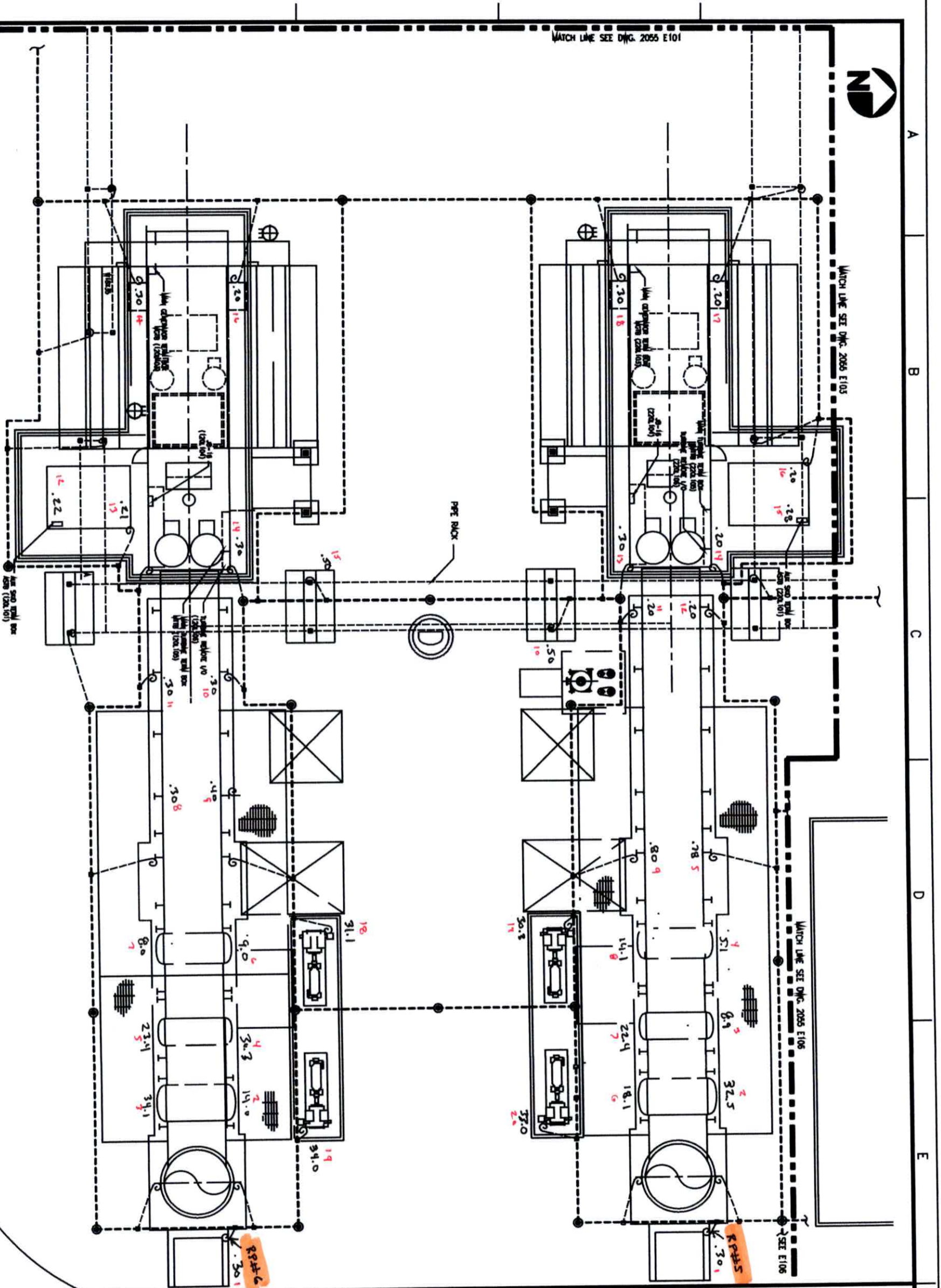

GENERAL NOTES:

1. FOR UNDERGROUND GROUNDING DETAILS SEE SPECIFICATION 2055 206.1 ELECTRICAL INSTALLATION.
2. GROUNDING CONDUCTORS FOR UNDERGROUND INSTALLATION SHALL BE 4/0MIL SORT DRAIN COPPER CABLE.
3. UNDERGROUND GROUNDING CONDUCTORS SHALL BE BURIED A MINIMUM 18" BELOW FRESH GRADE. GROUNDING ELECTRODES SHALL BE BENTON A MINIMUM OF 18" BELOW FRESH GRADE.
4. GROUNDING ELECTRODES SHALL BE 3/4" x 10" UNPLATED COPPER CLAD GROUND ROD.
5. A MINIMUM 15' OF CABLE SHALL BE INSTALLED ABOVE UNDERGROUND AT EACH POINT OR EQUIPMENT LOCATION. CABLE SHALL BE CUT TO FIT AT THE TIME OF CONNECTION.
6. GROUNDING CONDUCTORS SHALL NOT PERMEATE CONDUIT-MENT AREA PIPES OR FLOOR SLABS.
7. GROUNDING CONDUCTORS SHALL BE INSTALLED IN PVC CONDUIT WHERE CABLE PENETRATES FLOOR SLABS, EQUIPMENT PANS, OR RUN LENGTHS EXCEEDING 3' ABOVEGROUND.
8. GROUNDING CONDUCTORS RUN WITH U/G DUCT BANKS SHALL BE STUCCOED UP IN PVC BESIDE CONDUIT AT THE END OF EACH DUCT BANK.

- DENOTES CABLE TO CABLE CONNECTION
- DENOTES GROUND ROD
- ◐ DENOTES CABLE TO GROUND ROD CONNECTION
- ◑ DENOTES 18" PPE (ABSORBER) 4/0MIL SORT DRAIN COPPER CABLE
- DENOTES 4/0MIL SORT DRAIN COPPER CABLE

REFERENCES:

- 2055 E16 ELECTRICAL U/G & LAMPING KEY PLAN
- 2055 E101 TRANSFORMER VARY GROUNDING PLAN
- 2055 E103 SITE AREA GROUNDING PLAN
- 2055 E106 CHILLER GAS COND. BLDG. GROUNDING PLAN

NO.	REVISION	DESCRIPTION	BY	CHECKED	DATE
1					
2					
3					
4					
5					



DATE: 1-15-11
 SCALE: 1/8" = 1'-0"
 DRAWN BY: J. H. HARRIS
 CHECKED BY: J. H. HARRIS
 APPROVED BY: J. H. HARRIS

ORANGE COGENERATION FACILITY
 BATTERY FLOOR

GROUNDING PLAN
 HRSG/GTG AREA

DWG. NO. 2055 E104

CAD FILE: ORANGE104



A B C D E F

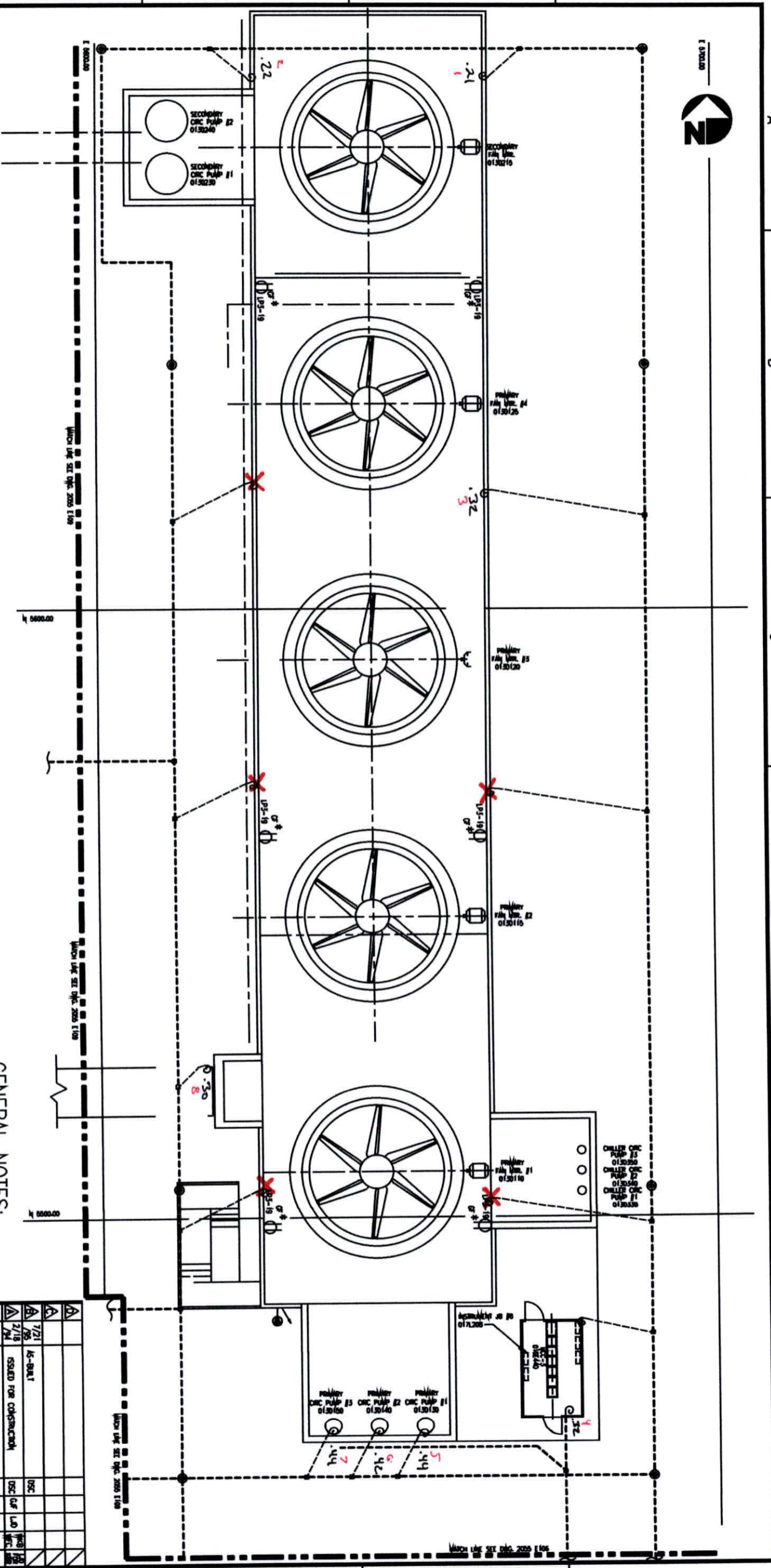

X - missing grounds

9. GROUNDING CONDUCTORS AT COOLING TOWER SHALL BE COILED FOR CONNECTION TO LIGHTNING PROTECTION SYSTEM.
7. GROUNDING CONDUCTORS SHALL BE INSTALLED IN PVC CONDUIT WHERE CABLE PENETRATES FLOOR SLABS, EQUIPMENT PADS, OR ROOF LENGTHS EXCEEDING 3' ABOVEGROUND.
8. GROUNDING CONDUCTORS RUN WITH U/G DUCT BUNDLES SHALL BE STUBBED UP IN PVC BESIDE CONDUIT AT THE END OF EACH DUCT BANK.

REFERENCES:

- 2005 E106 ELECTRICAL U/G & LIGHTNING KEY PLAN
- 2005 E106 CHILLER GAS CONDENSING PLAN
- 2005 E109 ZERO WASTE AREA GROUNDING PLAN

GENERAL NOTES:

- FOR UNDERGROUND GROUNDING DETAILS SEE SPECIFICATION 2005 206.1 ELECTRICAL INSTALLATION.
- GROUNDING CONDUCTORS FOR UNDERGROUND INSTALLATION SHALL BE 4/0MCM SOFT DRAWN COPPER CABLE.
- UNDERGROUND GROUNDING CONDUCTORS SHALL BE BURIED A MINIMUM 1'-6" BELOW FINISH GRADE. GROUNDING ELECTRODES SHALL BE BENTON A MINIMUM OF 3'-6" BELOW FINISH GRADE.
- GROUNDING ELECTRODES SHALL BE 3/4" x 10' MINIMUM COPPER CLAD GROUND ROD.
- A MINIMUM 15' OF CABLE SHALL BE INSTALLED ABOVE FINISH GRADE AT EACH PAD/M, OR EQUIPMENT LOCATION. CABLE SHALL BE CUT TO FIT AT THE TIME OF CONNECTION.
- GROUNDING CONDUCTORS SHALL NOT PENETRATE CONTAINMENT AREA WALLS OR FLOOR SLABS.

- DENOTES CABLE TO CABLE CONNECTION
- DENOTES GROUND ROD
- DENOTES CABLE TO GROUND ROD CONNECTION
- DENOTES 15' PIGTAIL (ABOVEGROUND 4/0MCM SOFT DRAWN COPPER CABLE)
- DENOTES 4/0MCM SOFT DRAWN COPPER CABLE

NO.	DATE	DESCRIPTION	BY	CHECKED	PROVED	APPROVED
1	7/21/05	AS-BUILT	OSG	CAF	LJD	REV
2	7/18/05	ISSUED FOR CONSTRUCTION	OSG	CAF	LJD	REV



NATIONAL ENERGY PRODUCTION CORPORATION
ORANGE COGENERATION FACILITY
ORANGE COGENERATION LP
BARTON, FLORIDA
COOLING TOWER AREA

SCALE:	1/8" = 1'-0"	DATE:	1-12-05
THIS DRAWING IS THE PROPERTY OF ZURN/NEPCO AND IS NOT TO BE USED IN ANY WAY WITHOUT PERMISSION TO THEIR EMPLOYEES AND IS TO BE RETURNED UPON REQUEST.			
DWG. NO.	2055 E105	REV	A

2
REV
27.9

A B C D E F

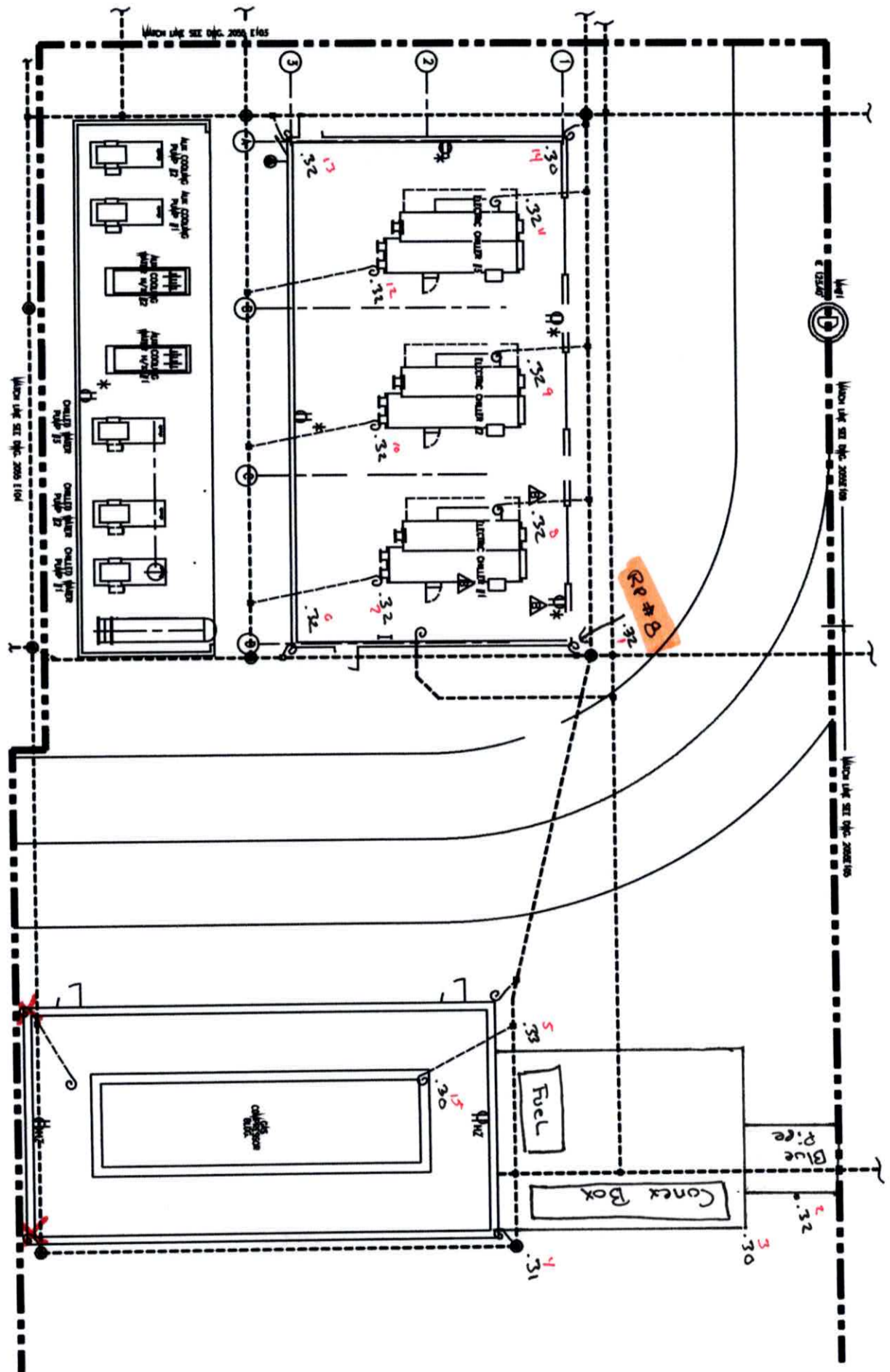

GENERAL NOTES:

1. FOR UNDERGROUND GROUNDING RITHS SEE SPECIFICATION 2005 206.1 ELECTRICAL INSTALLATION.
2. GROUNDING CONDUCTORS FOR UNDERGROUND INSTALLATION SHALL BE 4/0AWG SOFT DRAWN COPPER CABLE.
3. UNDERGROUND GROUNDING CONDUCTORS SHALL BE BARED 18" MINIMUM AT EACH POINT OF EQUIPMENT LOCATION. ELECTRODES SHALL BE BARED 18" MINIMUM AT EACH POINT OF EQUIPMENT LOCATION.
4. GROUNDING ELECTRODES SHALL BE 3/4" x 10' MINIMUM COPPER CLAD GROUND ROD.
5. A MINIMUM 15' OF CABLE SHALL BE INSTALLED ABOVE FINISH GRADE AT EACH POINT OF EQUIPMENT LOCATION. CABLE SHALL BE CUT TO FIT AT THE TIME OF CONNECTION.
6. GROUNDING CONDUCTORS SHALL NOT PENETRATE CONDUIT-VENT AREA WALLS OR FLOOR SLABS.
7. GROUNDING CONDUCTORS SHALL BE INSTALLED IN PVC CONDUIT WHERE CABLE PENETRATES FLOOR SLABS, EQUIPMENT PANS, OR RUN LENGTHS EXCEEDING 3' ABOVEGROUND.
8. GROUNDING CONDUCTORS RUN WITH V/G DUCT BUNDLES SHALL BE STRAPPED UP IN PVC ESSOR CONDUIT AT THE END OF EACH DUCT RUN.

- DEPOINTS CABLE TO CABLE CONNECTION
- DEPOINTS GROUND ROD
- DEPOINTS CABLE TO GROUND ROD CONNECTION
- DEPOINTS 15' PER IN. ABOVEGROUND 4/0AWG SOFT DRAWN COPPER CABLE
- DEPOINTS 4/0AWG SOFT DRAWN COPPER CABLE

REFERENCE DRAWINGS:

- 2005 E16 ELECTRICAL V/G & LEADING KEY PLAN
- 2005 E104 HESS'S GAS AREA GROUNDING PLAN
- 2005 E106 CHILLER GAS COMP. BLDG. GROUNDING PLAN
- 2005 E107 PAINT SERVICES BLDG. GROUNDING PLAN
- 2005 E109 WASTE AREA GROUNDING PLAN
- 2005 E306 GAS COMP. CHILLER AREA V/G RECEPTOR PLAN

NO.	DATE	DESCRIPTION	BY	CHKD.	APP'D.
1	7/21	AS-BUILT			
2	7/19	ISSUED FOR CONSTRUCTION			
3	7/19				
4					
5					

X - missing grounds

ZURN NATIONAL ENERGY PRODUCTION CORPORATION

NEPCO

ENGINEERED BY: G. HALL

SCALE: 1/8"=1'

DATE: 1-27-04

THIS DRAWING IS THE PROPERTY OF ZURN/NEPCO AND IS NOT TO BE USED BY ANY OTHER PERSONS TO THEIR INTERESTS AND IS TO BE RETURNED UPON REQUEST.

ORANGE COGENERATION FACILITY

GAS COMPRESSOR BLDG & CHILLER AREA

BRITTON, FLORIDA

GROUNDING PLAN

2055 E106

REV

DWG. NO. 2055 E106

DATE: 02/20/04



Orange Cogen
Test Reports
Post-Outage - IR Scanning
Job #OCFL2310067



Empowering Electrical Infrastructure
for a Sustainable Future



Testing and Commissioning Services

6625 Network Way, Indianapolis, IN 46278

www.hva-inc.com/pc-field-services/

Equipment Tested: Switch-yard and buss duct

Scope of Work: IR scan Post-outage

Observations and Recommendations:

Results: Good - no hot spots

Thermography Report

Client	Orange Cogen
Address	Bartow, Florida
Date	10/13/2023
Inspector	Andrew Kirk



T2 - GSU - H0 BUSHING

Measurements		Image Parameters	
Image:Max. Temp.	114.1°F	Distance	1.5m
Image:Min. Temp.	50.0°F	Humidity	60%
P1	96.1°F	Emissivity	0.97
		Reflected Temp.	77.0°F
		Atmospheric Temp.	85.2°F

Measurement Parameters		Device Information	
P1:Emissivity	0.97	Device Model	SP60
P1:Reflected Temp.	77.0°F	Device Serial No.	L26310272
P1:Distance	1.5m	Captured At	2023-10-13 12:57:54

Text Annotation



T2 - GSU - HIGH SIDE BUSHINGS

Measurements		Image Parameters	
Image:Max. Temp.	113.4°F	Distance	1.5m
Image:Min. Temp.	50.9°F	Humidity	60%
P1	95.0°F	Emissivity	0.97
P2	88.2°F	Reflected Temp.	77.0°F
P3	103.1°F	Atmospheric Temp.	85.2°F

Measurement Parameters		Device Information	
P1:Emissivity	0.97	Device Model	SP60
P1:Reflected Temp.	77.0°F	Device Serial No.	L26310272
P1:Distance	1.5m	Captured At	2023-10-13 12:57:35
P2:Emissivity	0.97		
P2:Reflected Temp.	77.0°F		
P2:Distance	1.5m		
P3:Emissivity	0.97		



T2 - GSU - HIGH SIDE BUSHINGS

Measurements		Image Parameters	
Image:Max. Temp.	114.1°F	Distance	1.5m
Image:Min. Temp.	57.9°F	Humidity	60%
P1	92.7°F	Emissivity	0.97
		Reflected Temp.	77.0°F
		Atmospheric Temp.	85.2°F

Measurement Parameters		Device Information	
P1:Emissivity	0.97	Device Model	SP60
P1:Reflected Temp.	77.0°F	Device Serial No.	L26310272
P1:Distance	1.5m	Captured At	2023-10-13 12:57:09

Text Annotation



T2 - GSU - HIGH SIDE BUSHINGS

Measurements		Image Parameters	
Image:Max. Temp.	118.0°F	Distance	1.5m
Image:Min. Temp.	51.6°F	Humidity	60%
P1	96.4°F	Emissivity	0.97
P2	99.3°F	Reflected Temp.	77.0°F
		Atmospheric Temp.	85.3°F

Measurement Parameters		Device Information	
P1:Emissivity	0.97	Device Model	SP60
P1:Reflected Temp.	77.0°F	Device Serial No.	L26310272
P1:Distance	1.5m	Captured At	2023-10-13 12:56:25
P2:Emissivity	0.97		
P2:Reflected Temp.	77.0°F		
P2:Distance	1.5m		

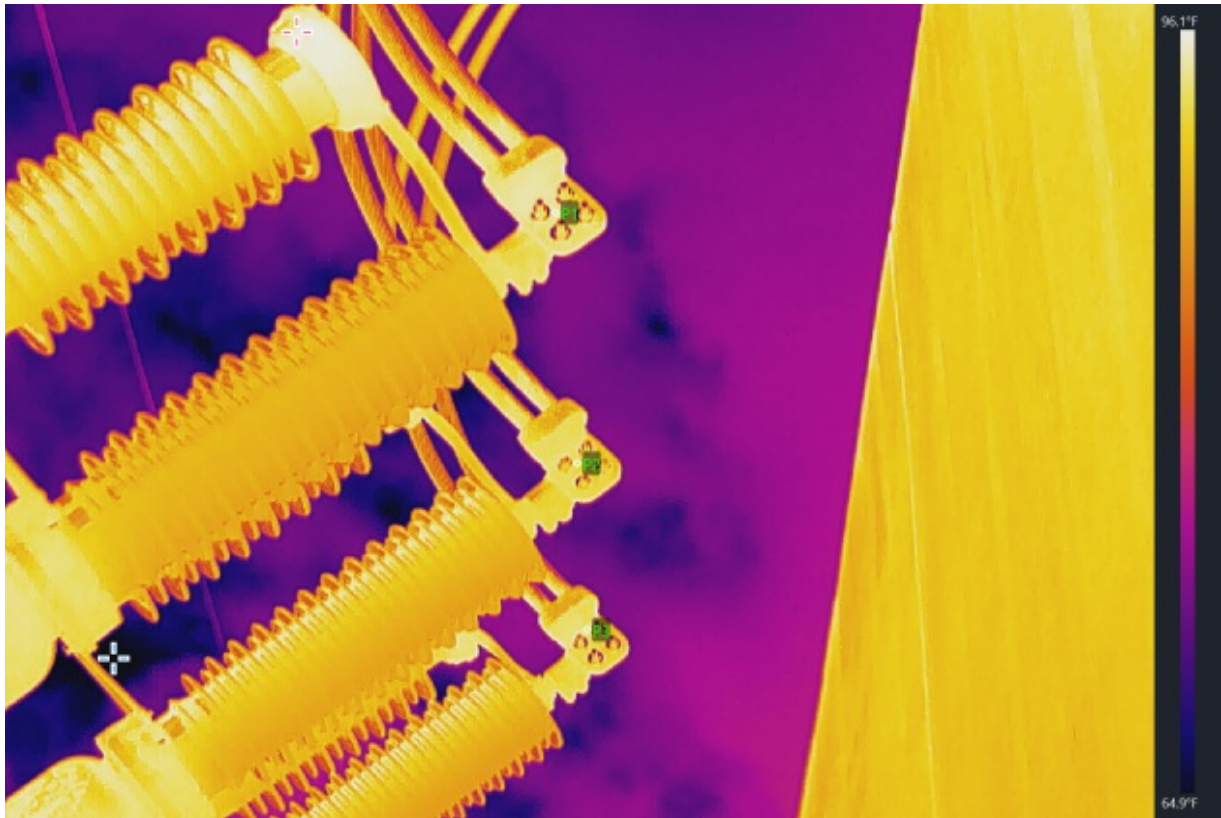

52-L2 - SF6 BREAKER

Measurements		Image Parameters	
Image:Max. Temp.	96.1°F	Distance	1.5m
Image:Min. Temp.	64.9°F	Humidity	60%
P1	94.1°F	Emissivity	0.97
P2	93.0°F	Reflected Temp.	77.0°F
P3	93.2°F	Atmospheric Temp.	85.2°F

Measurement Parameters		Device Information	
P1:Emissivity	0.97	Device Model	SP60
P1:Reflected Temp.	77.0°F	Device Serial No.	L26310272
P1:Distance	1.5m	Captured At	2023-10-13 12:55:43
P2:Emissivity	0.97		
P2:Reflected Temp.	77.0°F		
P2:Distance	1.5m		
P3:Emissivity	0.97		

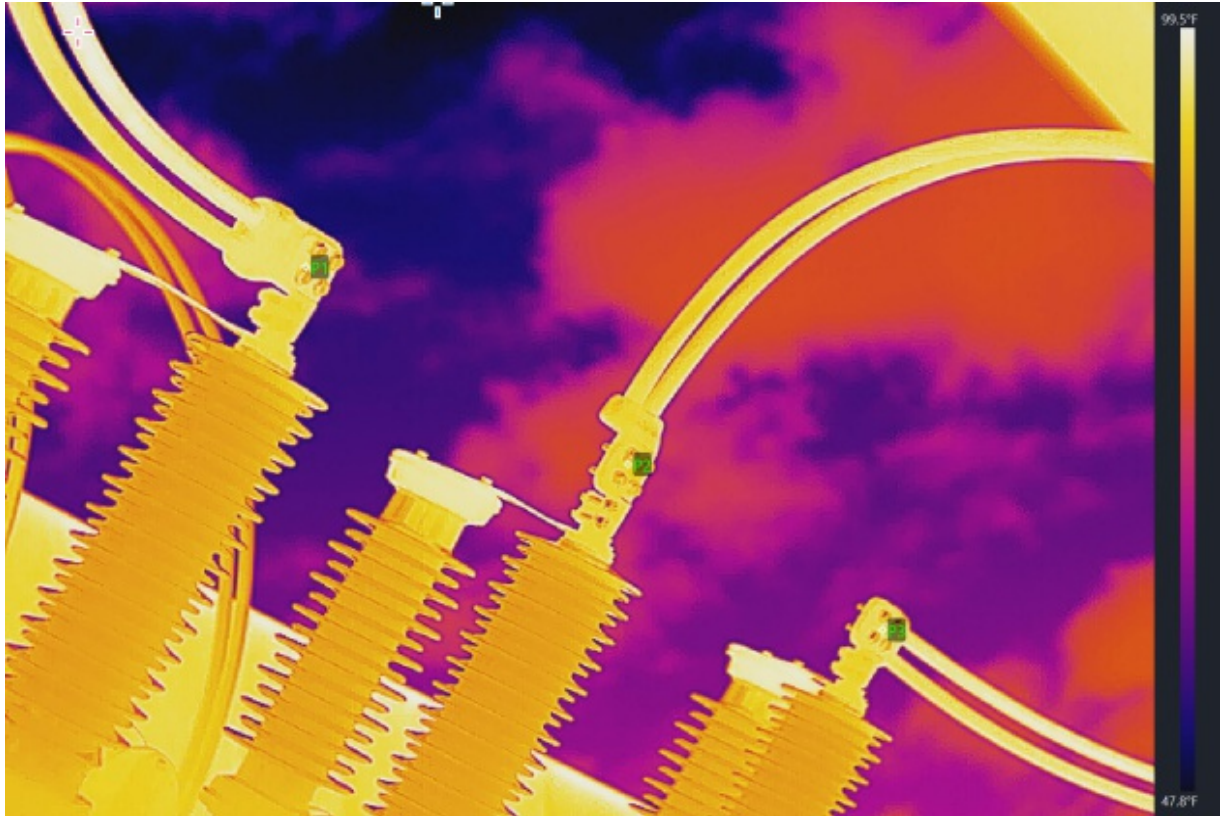

52-L2 - SF6 BREAKER

Measurements		Image Parameters	
Image:Max. Temp.	99.5°F	Distance	1.5m
Image:Min. Temp.	47.8°F	Humidity	60%
P1	92.3°F	Emissivity	0.97
P2	93.4°F	Reflected Temp.	77.0°F
P3	95.0°F	Atmospheric Temp.	85.3°F

Measurement Parameters		Device Information	
P1:Emissivity	0.97	Device Model	SP60
P1:Reflected Temp.	77.0°F	Device Serial No.	L26310272
P1:Distance	1.5m	Captured At	2023-10-13 12:55:16
P2:Emissivity	0.97		
P2:Reflected Temp.	77.0°F		
P2:Distance	1.5m		
P3:Emissivity	0.97		

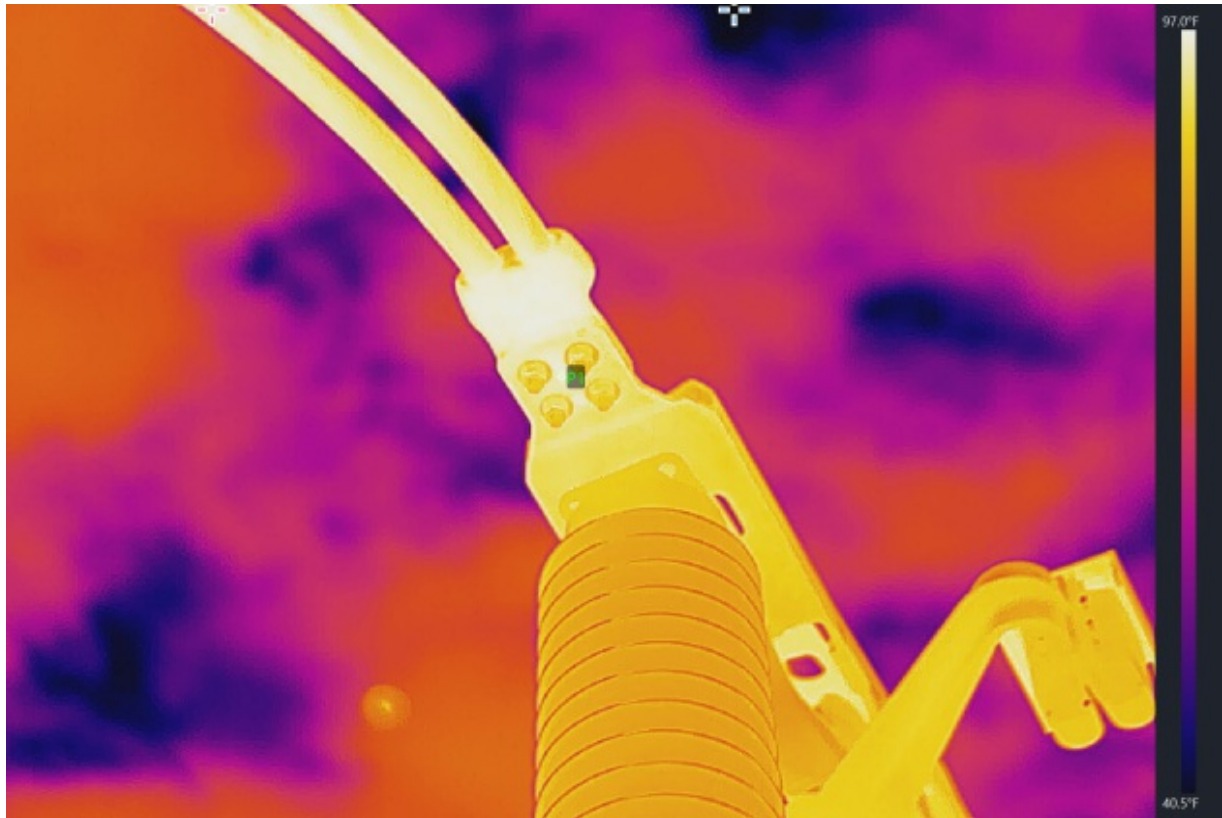

T2- MAIN AIR SWITCH

Measurements		Image Parameters	
Image:Max. Temp.	97.0°F	Distance	1.5m
Image:Min. Temp.	40.5°F	Humidity	60%
P1	95.5°F	Emissivity	0.97
		Reflected Temp.	77.0°F
		Atmospheric Temp.	85.2°F

Measurement Parameters		Device Information	
P1:Emissivity	0.97	Device Model	SP60
P1:Reflected Temp.	77.0°F	Device Serial No.	L26310272
P1:Distance	1.5m	Captured At	2023-10-13 12:55:02

Text Annotation



T2 - MAIN AIR SWITCH

Measurements		Image Parameters	
Image:Max. Temp.	107.8°F	Distance	1.5m
Image:Min. Temp.	57.2°F	Humidity	60%
P1	98.6°F	Emissivity	0.97
P2	100.6°F	Reflected Temp.	77.0°F
		Atmospheric Temp.	85.2°F

Measurement Parameters		Device Information	
P1:Emissivity	0.97	Device Model	SP60
P1:Reflected Temp.	77.0°F	Device Serial No.	L26310272
P1:Distance	1.5m	Captured At	2023-10-13 12:54:39
P2:Emissivity	0.97		
P2:Reflected Temp.	77.0°F		
P2:Distance	1.5m		



T2 - MAIN AIR SWITCH

Measurements		Image Parameters	
Image:Max. Temp.	100.9°F	Distance	1.5m
Image:Min. Temp.	50.2°F	Humidity	60%
P1	97.7°F	Emissivity	0.97
		Reflected Temp.	77.0°F
		Atmospheric Temp.	85.3°F

Measurement Parameters		Device Information	
P1:Emissivity	0.97	Device Model	SP60
P1:Reflected Temp.	77.0°F	Device Serial No.	L26310272
P1:Distance	1.5m	Captured At	2023-10-13 12:53:55

Text Annotation

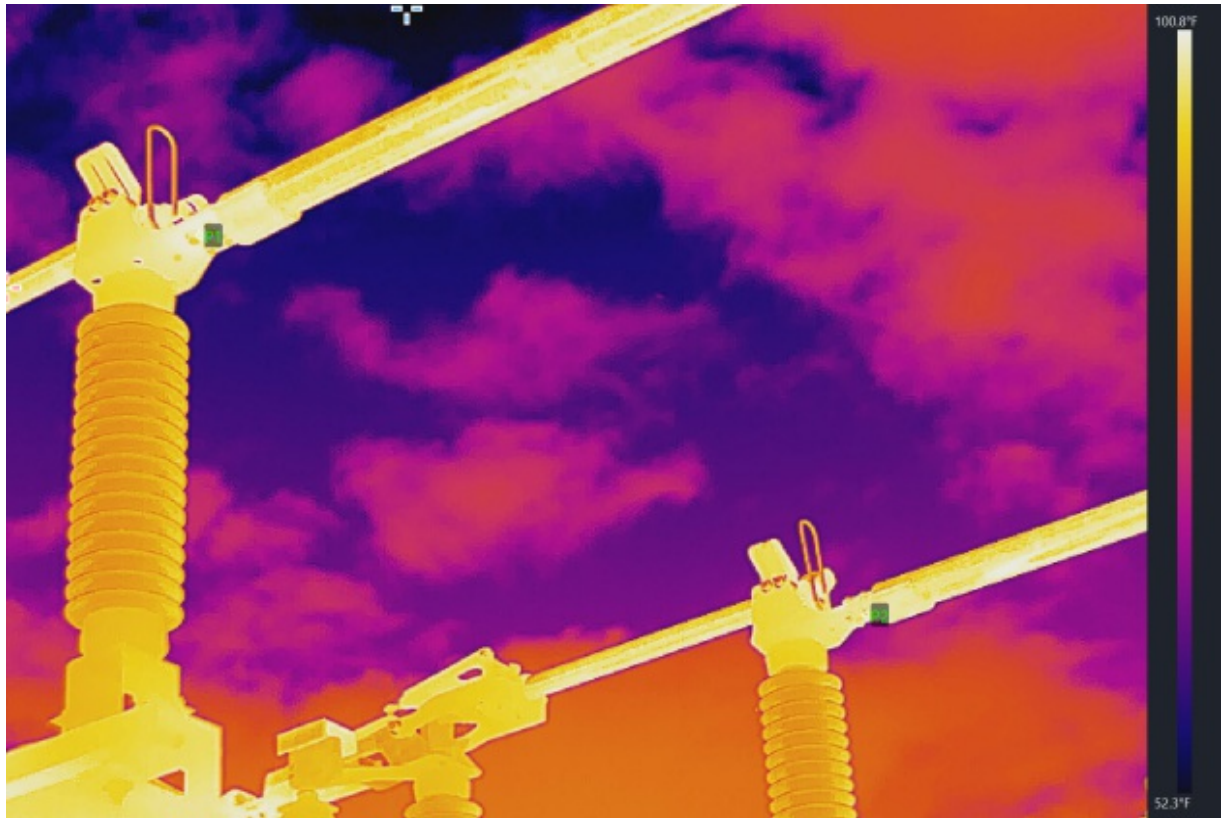

T2 - MAIN AIR SWITCH

Measurements		Image Parameters	
Image:Max. Temp.	100.8°F	Distance	1.5m
Image:Min. Temp.	52.3°F	Humidity	60%
P1	98.4°F	Emissivity	0.97
P2	95.4°F	Reflected Temp.	77.0°F
		Atmospheric Temp.	85.2°F

Measurement Parameters		Device Information	
P1:Emissivity	0.97	Device Model	SP60
P1:Reflected Temp.	77.0°F	Device Serial No.	L26310272
P1:Distance	1.5m	Captured At	2023-10-13 12:53:35
P2:Emissivity	0.97		
P2:Reflected Temp.	77.0°F		
P2:Distance	1.5m		



T1 - MAIN AIR SWITCH

Measurements		Image Parameters	
Image:Max. Temp.	99.5°F	Distance	1.5m
Image:Min. Temp.	51.6°F	Humidity	60%
P1	94.3°F	Emissivity	0.97
		Reflected Temp.	77.0°F
		Atmospheric Temp.	85.2°F

Measurement Parameters		Device Information	
P1:Emissivity	0.97	Device Model	SP60
P1:Reflected Temp.	77.0°F	Device Serial No.	L26310272
P1:Distance	1.5m	Captured At	2023-10-13 12:52:59

Text Annotation



T1 - MAIN AIR SWITCH

Measurements		Image Parameters	
Image:Max. Temp.	100.4°F	Distance	1.5m
Image:Min. Temp.	62.2°F	Humidity	60%
P1	94.8°F	Emissivity	0.97
P2	90.1°F	Reflected Temp.	77.0°F
P3	80.4°F	Atmospheric Temp.	85.2°F
P4	93.0°F		
P5	87.8°F		

Measurement Parameters		Device Information	
P1:Emissivity	0.97	Device Model	SP60
P1:Reflected Temp.	77.0°F	Device Serial No.	L26310272
P1:Distance	1.5m	Captured At	2023-10-13 12:52:41
P2:Emissivity	0.97		
P2:Reflected Temp.	77.0°F		

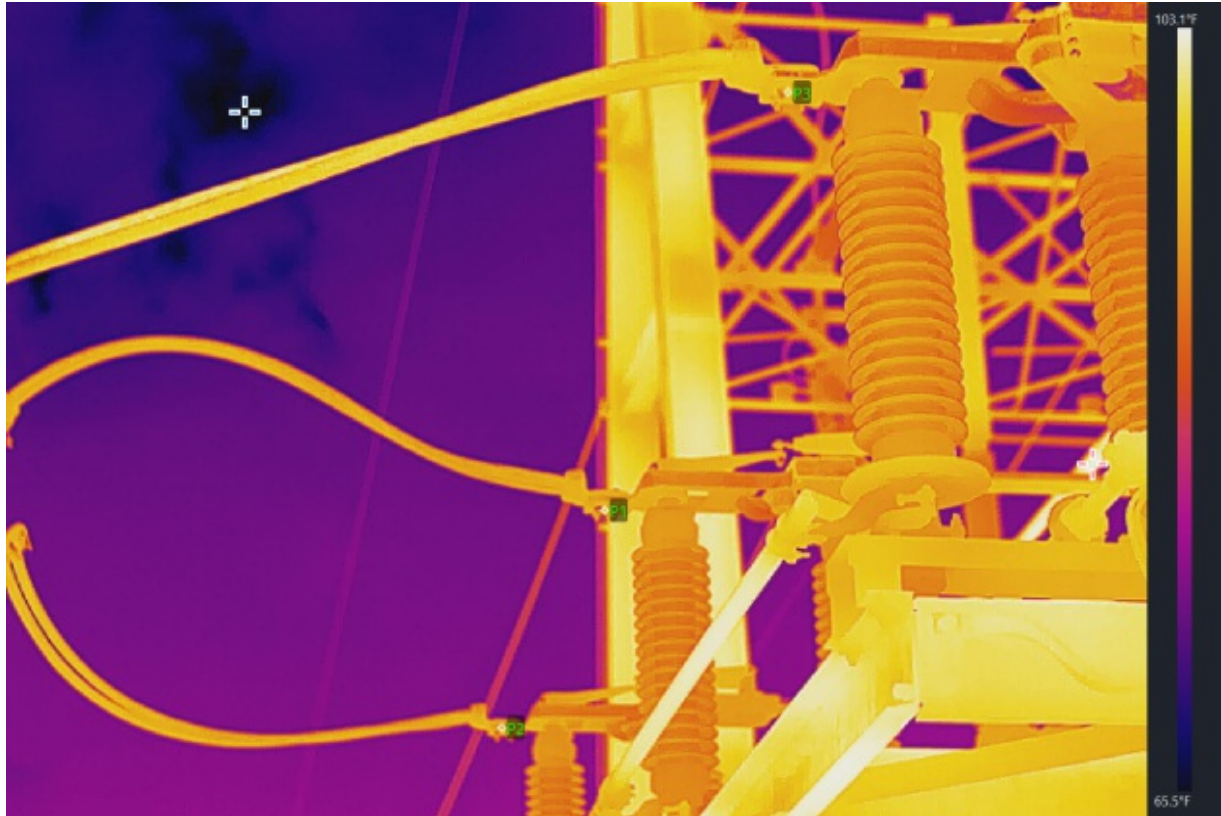

T1 - MAIN AIR SWITCH

Measurements		Image Parameters	
Image:Max. Temp.	103.1°F	Distance	1.5m
Image:Min. Temp.	65.5°F	Humidity	60%
P1	95.0°F	Emissivity	0.97
P2	93.6°F	Reflected Temp.	77.0°F
P3	95.5°F	Atmospheric Temp.	85.3°F

Measurement Parameters		Device Information	
P1:Emissivity	0.97	Device Model	SP60
P1:Reflected Temp.	77.0°F	Device Serial No.	L26310272
P1:Distance	1.5m	Captured At	2023-10-13 12:51:52
P2:Emissivity	0.97		
P2:Reflected Temp.	77.0°F		
P2:Distance	1.5m		
P3:Emissivity	0.97		

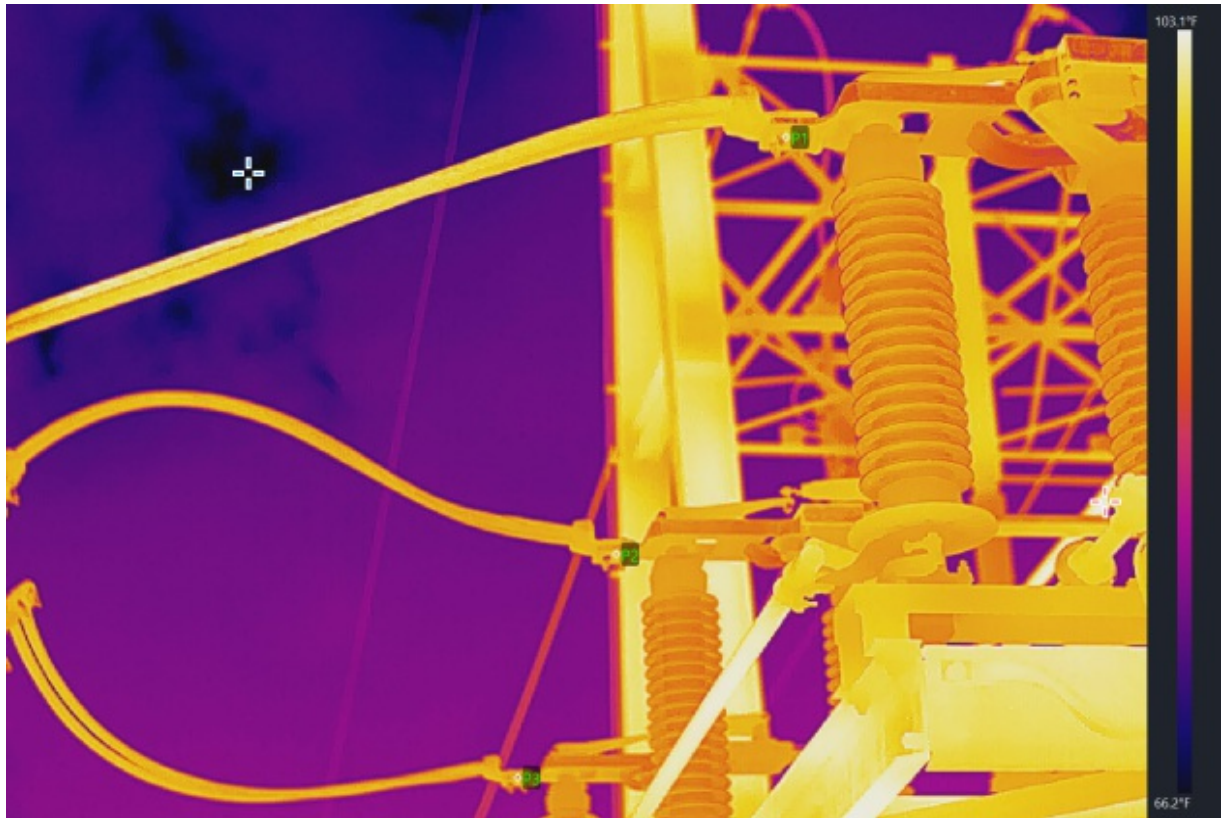

T1 - MAIN AIR SWITCH

Measurements		Image Parameters	
Image:Max. Temp.	103.1°F	Distance	1.5m
Image:Min. Temp.	66.2°F	Humidity	60%
P1	94.8°F	Emissivity	0.97
P2	94.8°F	Reflected Temp.	77.0°F
P3	92.3°F	Atmospheric Temp.	85.3°F

Measurement Parameters		Device Information	
P1:Emissivity	0.97	Device Model	SP60
P1:Reflected Temp.	77.0°F	Device Serial No.	L26310272
P1:Distance	1.5m	Captured At	2023-10-13 12:51:49
P2:Emissivity	0.97		
P2:Reflected Temp.	77.0°F		
P2:Distance	1.5m		
P3:Emissivity	0.97		

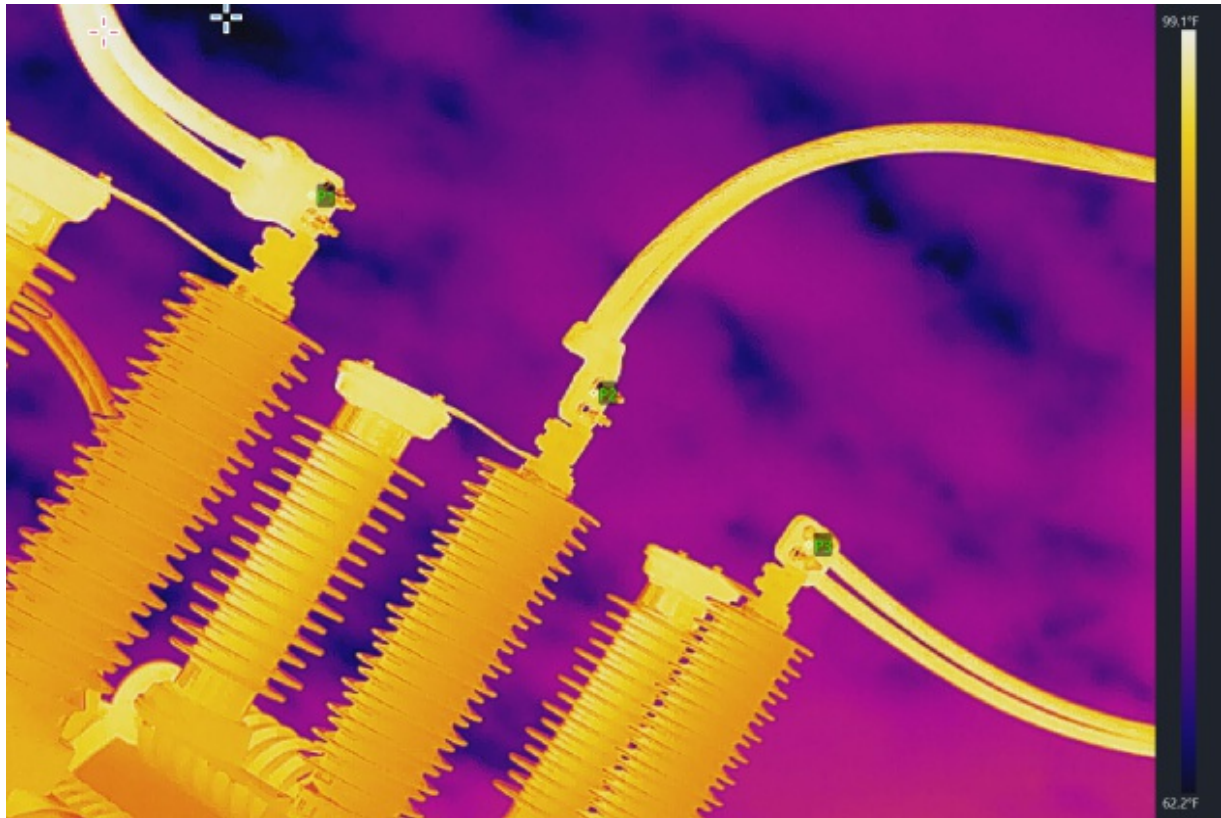

52-L1 - SF6 BREAKER

Measurements		Image Parameters	
Image:Max. Temp.	99.1°F	Distance	1.5m
Image:Min. Temp.	62.2°F	Humidity	60%
P1	95.7°F	Emissivity	0.97
P2	93.6°F	Reflected Temp.	77.0°F
P3	94.6°F	Atmospheric Temp.	85.2°F

Measurement Parameters		Device Information	
P1:Emissivity	0.97	Device Model	SP60
P1:Reflected Temp.	77.0°F	Device Serial No.	L26310272
P1:Distance	1.5m	Captured At	2023-10-13 12:51:05
P2:Emissivity	0.97		
P2:Reflected Temp.	77.0°F		
P2:Distance	1.5m		
P3:Emissivity	0.97		

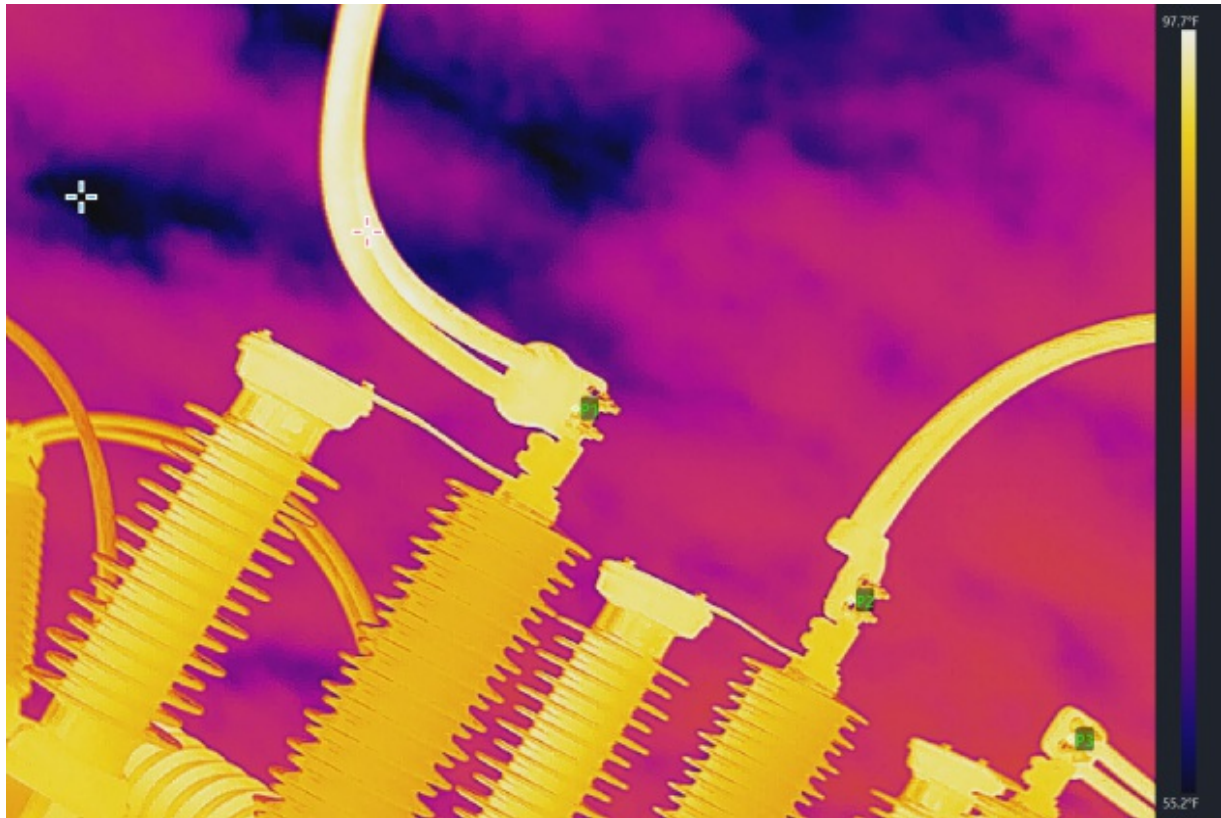

52-L1 - SF6 BREAKER

Measurements		Image Parameters	
Image:Max. Temp.	97.7°F	Distance	1.5m
Image:Min. Temp.	55.2°F	Humidity	60%
P1	94.5°F	Emissivity	0.97
P2	93.0°F	Reflected Temp.	77.0°F
P3	93.9°F	Atmospheric Temp.	85.2°F

Measurement Parameters		Device Information	
P1:Emissivity	0.97	Device Model	SP60
P1:Reflected Temp.	77.0°F	Device Serial No.	L26310272
P1:Distance	1.5m	Captured At	2023-10-13 12:50:34
P2:Emissivity	0.97		
P2:Reflected Temp.	77.0°F		
P2:Distance	1.5m		
P3:Emissivity	0.97		

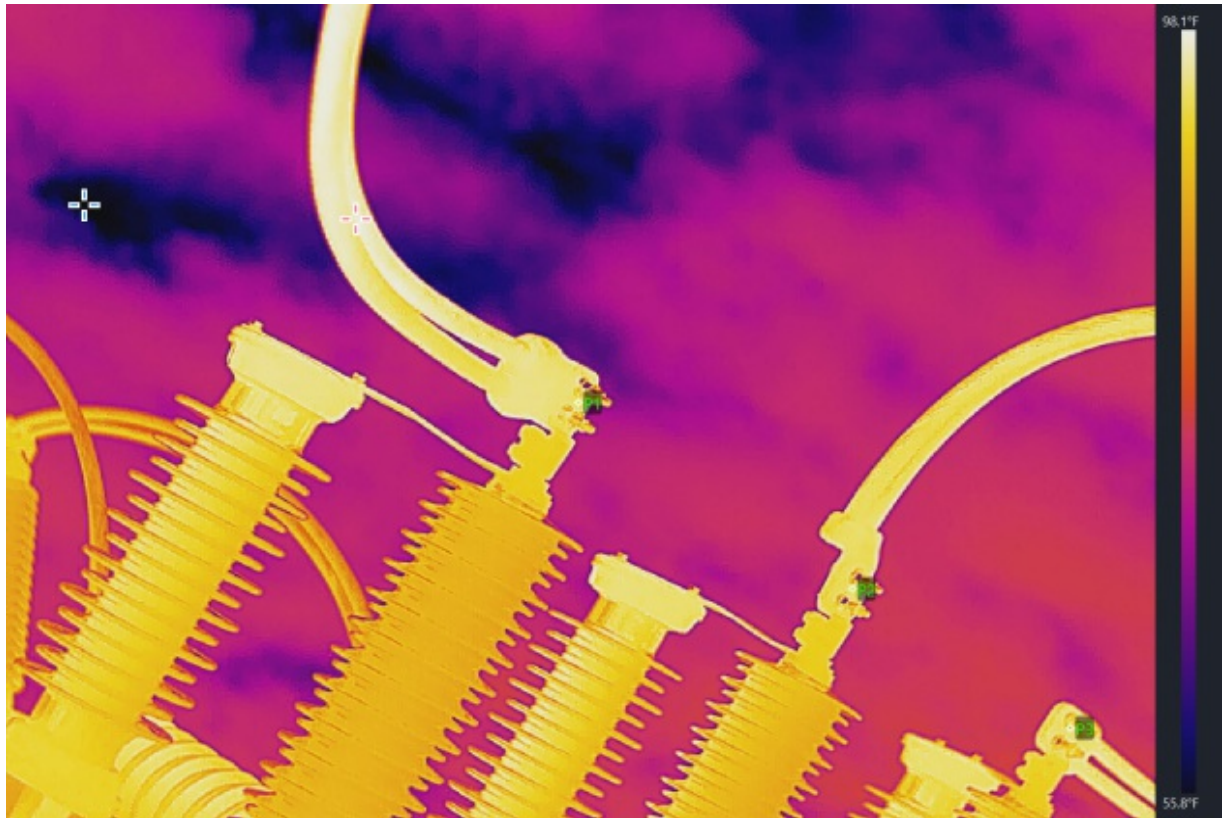

52-L1 - SF6 BREAKER

Measurements		Image Parameters	
Image:Max. Temp.	98.1°F	Distance	1.5m
Image:Min. Temp.	55.8°F	Humidity	60%
P1	94.5°F	Emissivity	0.97
P2	94.6°F	Reflected Temp.	77.0°F
P3	93.2°F	Atmospheric Temp.	85.2°F

Measurement Parameters		Device Information	
P1:Emissivity	0.97	Device Model	SP60
P1:Reflected Temp.	77.0°F	Device Serial No.	L26310272
P1:Distance	1.5m	Captured At	2023-10-13 12:50:32
P2:Emissivity	0.97		
P2:Reflected Temp.	77.0°F		
P2:Distance	1.5m		
P3:Emissivity	0.97		

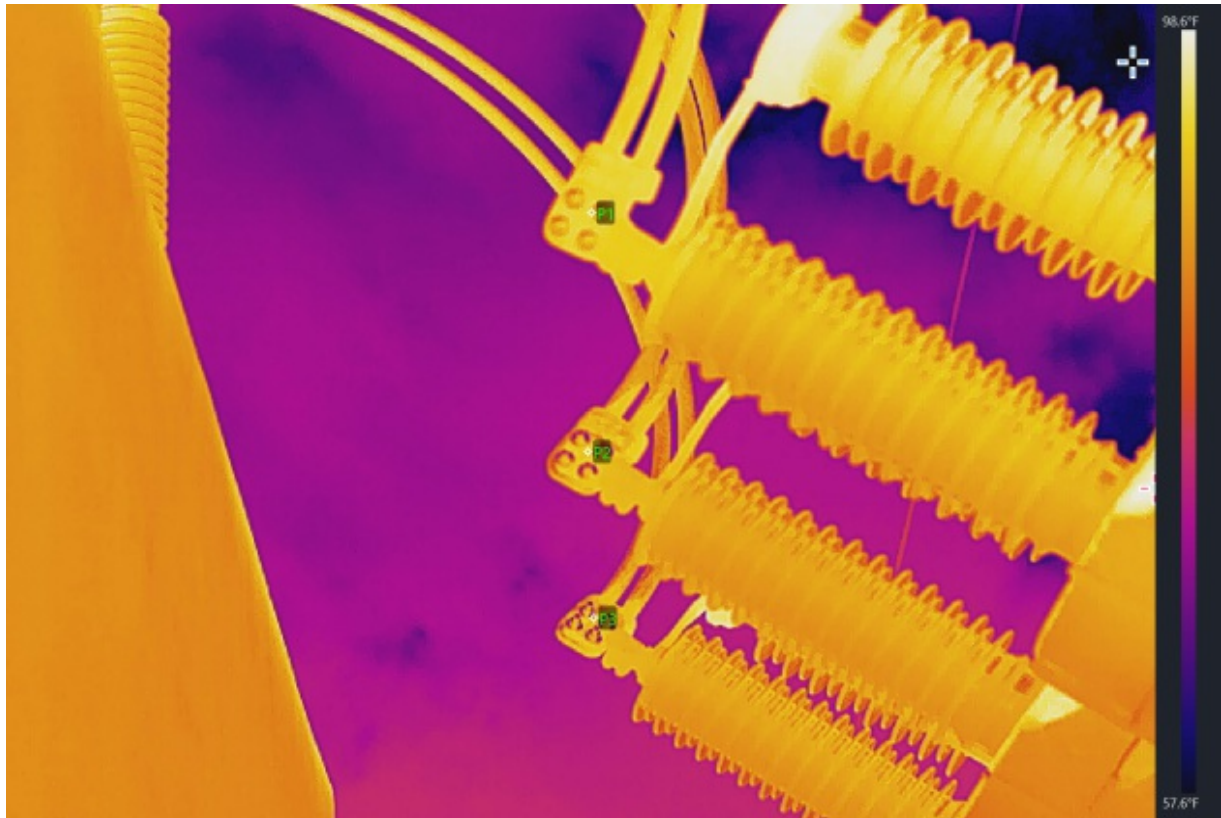

52-L1 - SF6 BREAKER

Measurements		Image Parameters	
Image:Max. Temp.	98.6°F	Distance	1.5m
Image:Min. Temp.	57.6°F	Humidity	60%
P1	91.2°F	Emissivity	0.97
P2	91.9°F	Reflected Temp.	77.0°F
P3	88.2°F	Atmospheric Temp.	86.2°F

Measurement Parameters		Device Information	
P1:Emissivity	0.97	Device Model	SP60
P1:Reflected Temp.	77.0°F	Device Serial No.	L26310272
P1:Distance	1.5m	Captured At	2023-10-13 12:50:21
P2:Emissivity	0.97		
P2:Reflected Temp.	77.0°F		
P2:Distance	1.5m		
P3:Emissivity	0.97		

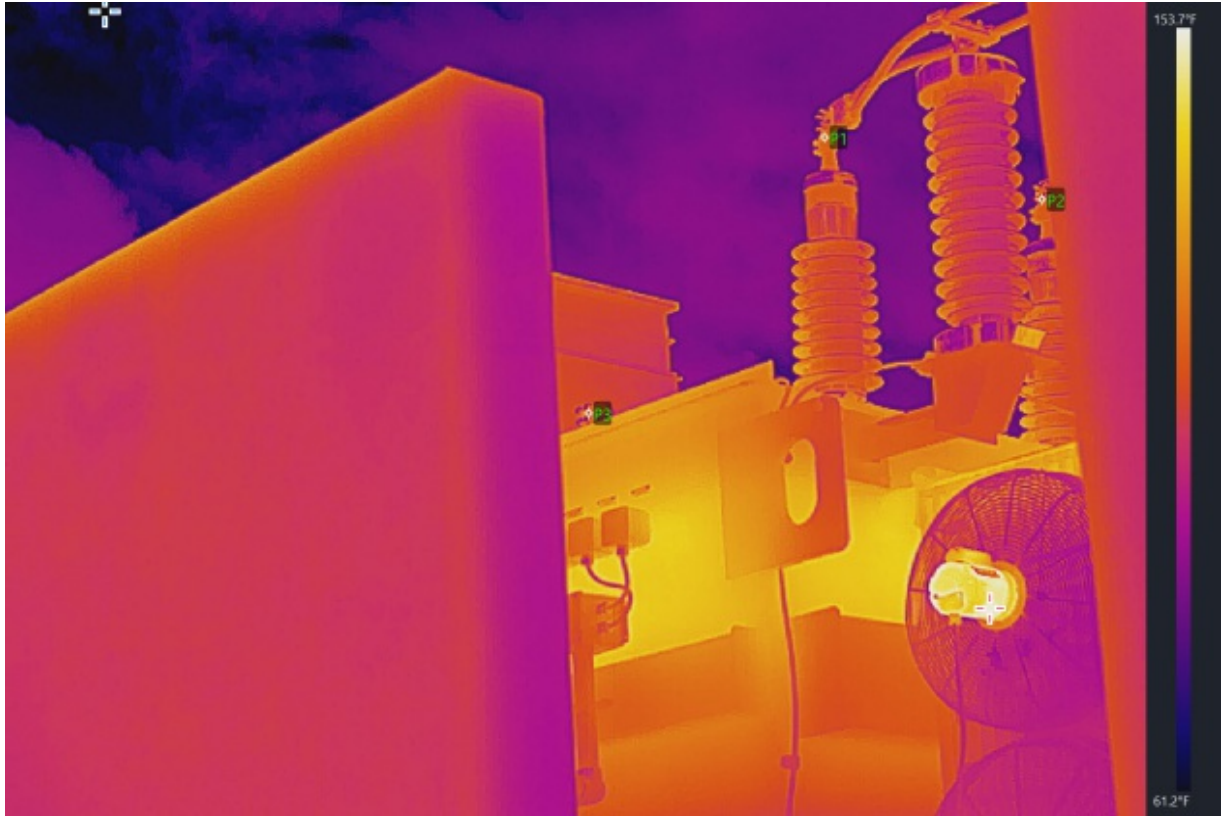

T1 - GSU - H0 BUSHING

Measurements		Image Parameters	
Image:Max. Temp.	153.7°F	Distance	1.5m
Image:Min. Temp.	61.2°F	Humidity	60%
P1	97.2°F	Emissivity	0.97
P2	94.6°F	Reflected Temp.	77.0°F
P3	95.7°F	Atmospheric Temp.	85.9°F

Measurement Parameters		Device Information	
P1:Emissivity	0.97	Device Model	SP60
P1:Reflected Temp.	77.0°F	Device Serial No.	L26310272
P1:Distance	1.5m	Captured At	2023-10-13 12:49:48
P2:Emissivity	0.97		
P2:Reflected Temp.	77.0°F		
P2:Distance	1.5m		
P3:Emissivity	0.97		



T1 - GSU - HIGH SIDE BUSHINGS

Measurements		Image Parameters	
Image:Max. Temp.	104.4°F	Distance	1.5m
Image:Min. Temp.	46.8°F	Humidity	60%
P1	96.8°F	Emissivity	0.97
P2	91.8°F	Reflected Temp.	77.0°F
P3	89.8°F	Atmospheric Temp.	87.3°F

Measurement Parameters		Device Information	
P1:Emissivity	0.97	Device Model	SP60
P1:Reflected Temp.	77.0°F	Device Serial No.	L26310272
P1:Distance	1.5m	Captured At	2023-10-13 12:48:52
P2:Emissivity	0.97		
P2:Reflected Temp.	77.0°F		
P2:Distance	1.5m		
P3:Emissivity	0.97		



T1 - GSU - HIGH SIDE BUSHINGS

Measurements		Image Parameters	
Image:Max. Temp.	109.4°F	Distance	1.5m
Image:Min. Temp.	64.2°F	Humidity	60%
P1	95.9°F	Emissivity	0.97
P2	97.2°F	Reflected Temp.	77.0°F
		Atmospheric Temp.	86.9°F

Measurement Parameters		Device Information	
P1:Emissivity	0.97	Device Model	SP60
P1:Reflected Temp.	77.0°F	Device Serial No.	L26310272
P1:Distance	1.5m	Captured At	2023-10-13 12:48:21
P2:Emissivity	0.97		
P2:Reflected Temp.	77.0°F		
P2:Distance	1.5m		



Orange Cogen
Test Reports
Post-Outage - IR Scanning
Job #OCFL2310067



Empowering Electrical Infrastructure
for a Sustainable Future



Testing and Commissioning Services

6625 Network Way, Indianapolis, IN 46278

www.hva-inc.com/pc-field-services/

Orange Cogen
1901 S. Clear Springs Rd
Bartow, FL 33830

David Courson,

We are pleased to present the field test reports for the IR scanning post-outage conducted by High Voltage Advanced. This report highlights the comprehensive analysis and results obtained during the field-testing phase, providing valuable insights into the performance and reliability of your electrical system under evaluation.

At HVA, we strive to deliver exceptional products and services, backed by rigorous testing and analysis. We understand the significance of the field test results in evaluating the effectiveness and safety of your electrical system. The information contained in this report is intended to provide you with a detailed overview of the performance characteristics, environmental considerations, and any observed issues during the testing phase.

Key Sections of the Field Test Report:

- **Equipment Tested:** all equipment that was tested during the field-testing phase.
- **Scope of Work:** Detailed explanation of the goals and objectives of the field test.
- **Observations and Recommendations:** Identification of any observed issues or challenges, accompanied by recommendations for improvement or further investigations, if necessary.
- **Results:** In-depth examination of the obtained data, including test data sheets, system behavior, and any deviations from expected outcomes at the time of testing.

We understand that your valuable feedback is crucial in our continuous efforts to enhance our offerings. Therefore, we encourage you to review the field test report thoroughly and reach out to us with any questions or concerns you may have. Our dedicated team of experts is available to provide further clarification or address any questions you may have.

We sincerely appreciate the opportunity to collaborate with you on this project and remain committed to delivering the highest quality solutions to meet your needs. Should you require any additional information or assistance, please do not hesitate to contact us.

Thank you for your trust and continued partnership.

Sincerely,

Matthew Falchetti

Lead Technician

NICET I #153748

Cell: (863)528-4124

HVA - P&C / Field Services

matt.falchetti@hva-inc.com

www.hva-inc.com/pc-field-services/



Chris Roehm

Field Services Manager

NICET III #152740

Cell: (843)818-8847

HVA - P&C / Field Services

chris.roehm@hva-inc.com

www.hva-inc.com/pc-field-services/





Testing and Commissioning Services

6625 Network Way, Indianapolis, IN 46278

www.hva-inc.com/pc-field-services/

Equipment Tested: Switch-yard and buss duct

Scope of Work: IR scan Post-outage

Observations and Recommendations:

Results: Good - no hot spots

Thermography Report

Client	Orange Cogen
Address	Bartow, Florida
Date	10/13/2023
Inspector	Andrew Kirk



T2 - GSU - H0 BUSHING

Measurements		Image Parameters	
Image:Max. Temp.	114.1°F	Distance	1.5m
Image:Min. Temp.	50.0°F	Humidity	60%
P1	96.1°F	Emissivity	0.97
		Reflected Temp.	77.0°F
		Atmospheric Temp.	85.2°F

Measurement Parameters		Device Information	
P1:Emissivity	0.97	Device Model	SP60
P1:Reflected Temp.	77.0°F	Device Serial No.	L26310272
P1:Distance	1.5m	Captured At	2023-10-13 12:57:54

Text Annotation



T2 - GSU - HIGH SIDE BUSHINGS

Measurements		Image Parameters	
Image:Max. Temp.	113.4°F	Distance	1.5m
Image:Min. Temp.	50.9°F	Humidity	60%
P1	95.0°F	Emissivity	0.97
P2	88.2°F	Reflected Temp.	77.0°F
P3	103.1°F	Atmospheric Temp.	85.2°F

Measurement Parameters		Device Information	
P1:Emissivity	0.97	Device Model	SP60
P1:Reflected Temp.	77.0°F	Device Serial No.	L26310272
P1:Distance	1.5m	Captured At	2023-10-13 12:57:35
P2:Emissivity	0.97		
P2:Reflected Temp.	77.0°F		
P2:Distance	1.5m		
P3:Emissivity	0.97		



T2 - GSU - HIGH SIDE BUSHINGS

Measurements		Image Parameters	
Image:Max. Temp.	114.1°F	Distance	1.5m
Image:Min. Temp.	57.9°F	Humidity	60%
P1	92.7°F	Emissivity	0.97
		Reflected Temp.	77.0°F
		Atmospheric Temp.	85.2°F

Measurement Parameters		Device Information	
P1:Emissivity	0.97	Device Model	SP60
P1:Reflected Temp.	77.0°F	Device Serial No.	L26310272
P1:Distance	1.5m	Captured At	2023-10-13 12:57:09

Text Annotation



T2 - GSU - HIGH SIDE BUSHINGS

Measurements		Image Parameters	
Image:Max. Temp.	118.0°F	Distance	1.5m
Image:Min. Temp.	51.6°F	Humidity	60%
P1	96.4°F	Emissivity	0.97
P2	99.3°F	Reflected Temp.	77.0°F
		Atmospheric Temp.	85.3°F

Measurement Parameters		Device Information	
P1:Emissivity	0.97	Device Model	SP60
P1:Reflected Temp.	77.0°F	Device Serial No.	L26310272
P1:Distance	1.5m	Captured At	2023-10-13 12:56:25
P2:Emissivity	0.97		
P2:Reflected Temp.	77.0°F		
P2:Distance	1.5m		

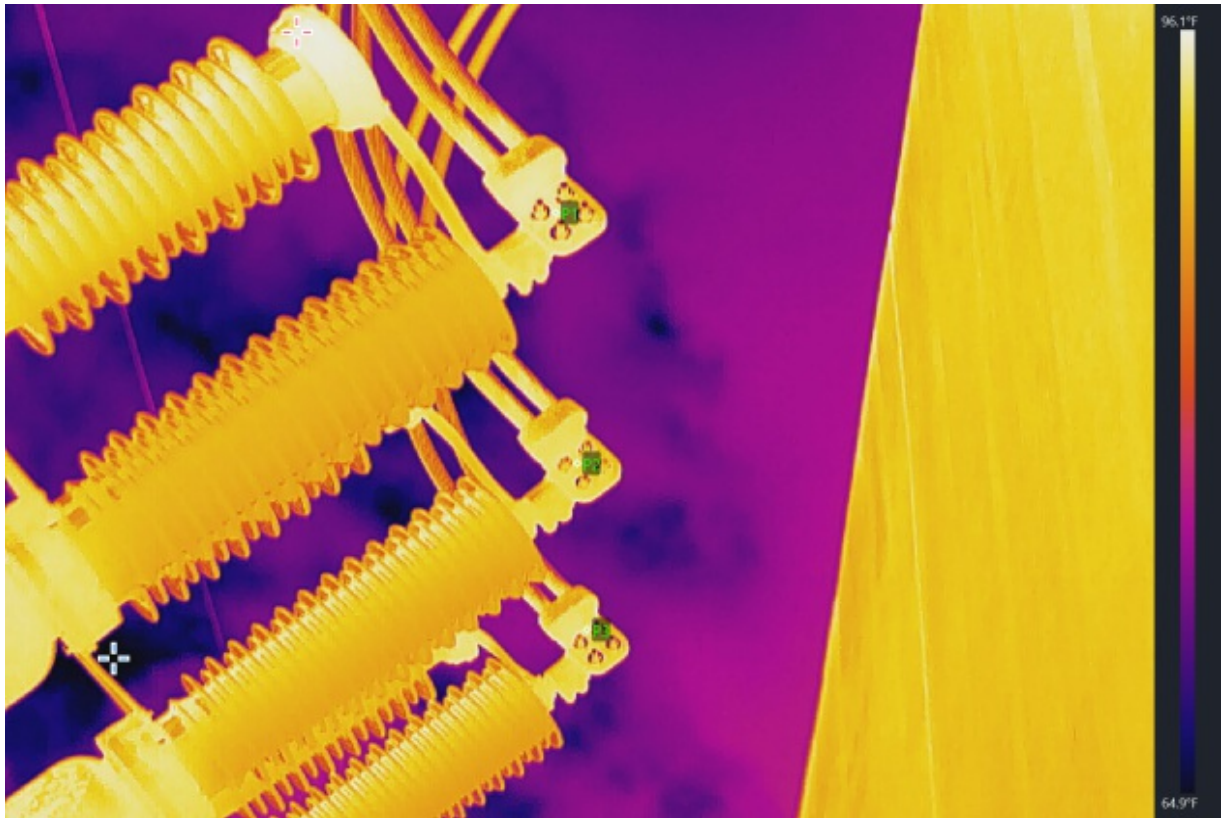

52-L2 - SF6 BREAKER

Measurements		Image Parameters	
Image:Max. Temp.	96.1°F	Distance	1.5m
Image:Min. Temp.	64.9°F	Humidity	60%
P1	94.1°F	Emissivity	0.97
P2	93.0°F	Reflected Temp.	77.0°F
P3	93.2°F	Atmospheric Temp.	85.2°F

Measurement Parameters		Device Information	
P1:Emissivity	0.97	Device Model	SP60
P1:Reflected Temp.	77.0°F	Device Serial No.	L26310272
P1:Distance	1.5m	Captured At	2023-10-13 12:55:43
P2:Emissivity	0.97		
P2:Reflected Temp.	77.0°F		
P2:Distance	1.5m		
P3:Emissivity	0.97		

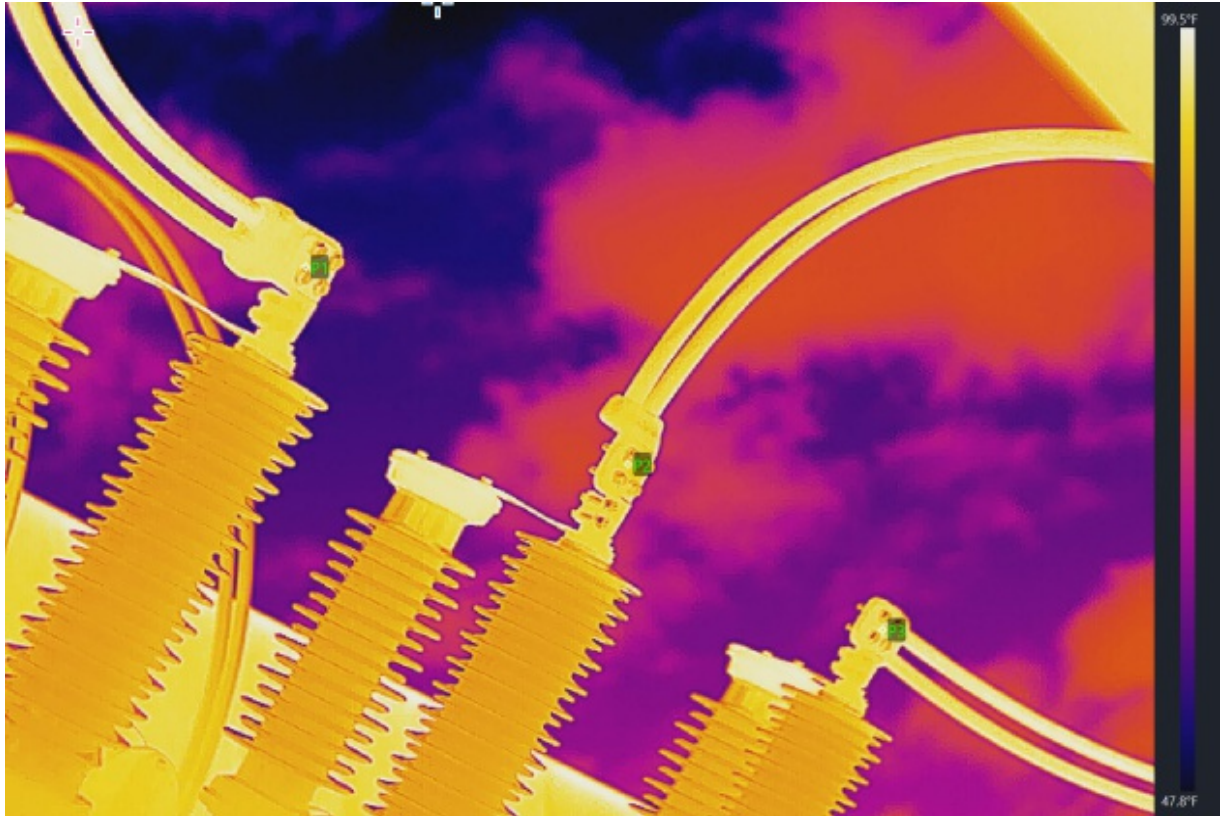

52-L2 - SF6 BREAKER

Measurements		Image Parameters	
Image:Max. Temp.	99.5°F	Distance	1.5m
Image:Min. Temp.	47.8°F	Humidity	60%
P1	92.3°F	Emissivity	0.97
P2	93.4°F	Reflected Temp.	77.0°F
P3	95.0°F	Atmospheric Temp.	85.3°F

Measurement Parameters		Device Information	
P1:Emissivity	0.97	Device Model	SP60
P1:Reflected Temp.	77.0°F	Device Serial No.	L26310272
P1:Distance	1.5m	Captured At	2023-10-13 12:55:16
P2:Emissivity	0.97		
P2:Reflected Temp.	77.0°F		
P2:Distance	1.5m		
P3:Emissivity	0.97		

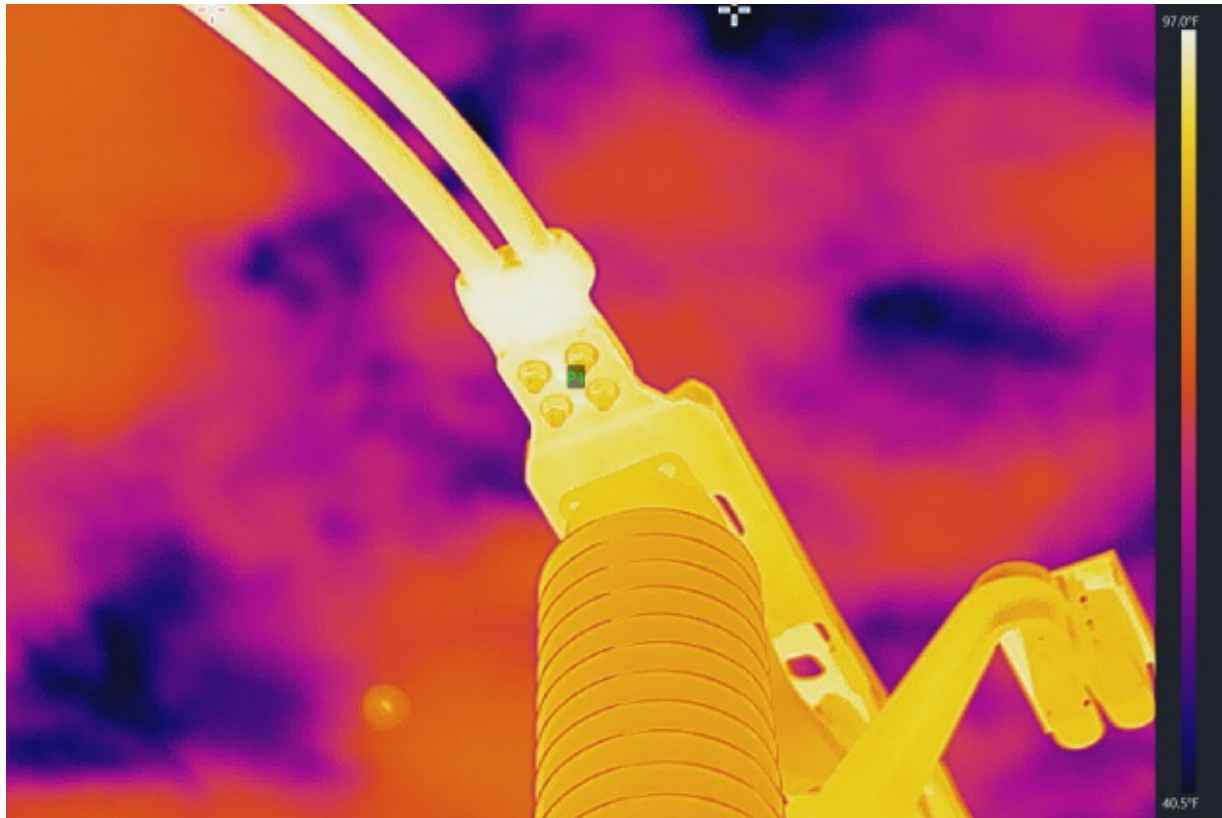

T2- MAIN AIR SWITCH

Measurements		Image Parameters	
Image:Max. Temp.	97.0°F	Distance	1.5m
Image:Min. Temp.	40.5°F	Humidity	60%
P1	95.5°F	Emissivity	0.97
		Reflected Temp.	77.0°F
		Atmospheric Temp.	85.2°F

Measurement Parameters		Device Information	
P1:Emissivity	0.97	Device Model	SP60
P1:Reflected Temp.	77.0°F	Device Serial No.	L26310272
P1:Distance	1.5m	Captured At	2023-10-13 12:55:02

Text Annotation



T2 - MAIN AIR SWITCH

Measurements		Image Parameters	
Image:Max. Temp.	107.8°F	Distance	1.5m
Image:Min. Temp.	57.2°F	Humidity	60%
P1	98.6°F	Emissivity	0.97
P2	100.6°F	Reflected Temp.	77.0°F
		Atmospheric Temp.	85.2°F

Measurement Parameters		Device Information	
P1:Emissivity	0.97	Device Model	SP60
P1:Reflected Temp.	77.0°F	Device Serial No.	L26310272
P1:Distance	1.5m	Captured At	2023-10-13 12:54:39
P2:Emissivity	0.97		
P2:Reflected Temp.	77.0°F		
P2:Distance	1.5m		



T2 - MAIN AIR SWITCH

Measurements		Image Parameters	
Image:Max. Temp.	100.9°F	Distance	1.5m
Image:Min. Temp.	50.2°F	Humidity	60%
P1	97.7°F	Emissivity	0.97
		Reflected Temp.	77.0°F
		Atmospheric Temp.	85.3°F

Measurement Parameters		Device Information	
P1:Emissivity	0.97	Device Model	SP60
P1:Reflected Temp.	77.0°F	Device Serial No.	L26310272
P1:Distance	1.5m	Captured At	2023-10-13 12:53:55

Text Annotation



T2 - MAIN AIR SWITCH

Measurements		Image Parameters	
Image:Max. Temp.	100.8°F	Distance	1.5m
Image:Min. Temp.	52.3°F	Humidity	60%
P1	98.4°F	Emissivity	0.97
P2	95.4°F	Reflected Temp.	77.0°F
		Atmospheric Temp.	85.2°F

Measurement Parameters		Device Information	
P1:Emissivity	0.97	Device Model	SP60
P1:Reflected Temp.	77.0°F	Device Serial No.	L26310272
P1:Distance	1.5m	Captured At	2023-10-13 12:53:35
P2:Emissivity	0.97		
P2:Reflected Temp.	77.0°F		
P2:Distance	1.5m		



T1 - MAIN AIR SWITCH

Measurements		Image Parameters	
Image:Max. Temp.	99.5°F	Distance	1.5m
Image:Min. Temp.	51.6°F	Humidity	60%
P1	94.3°F	Emissivity	0.97
		Reflected Temp.	77.0°F
		Atmospheric Temp.	85.2°F

Measurement Parameters		Device Information	
P1:Emissivity	0.97	Device Model	SP60
P1:Reflected Temp.	77.0°F	Device Serial No.	L26310272
P1:Distance	1.5m	Captured At	2023-10-13 12:52:59

Text Annotation

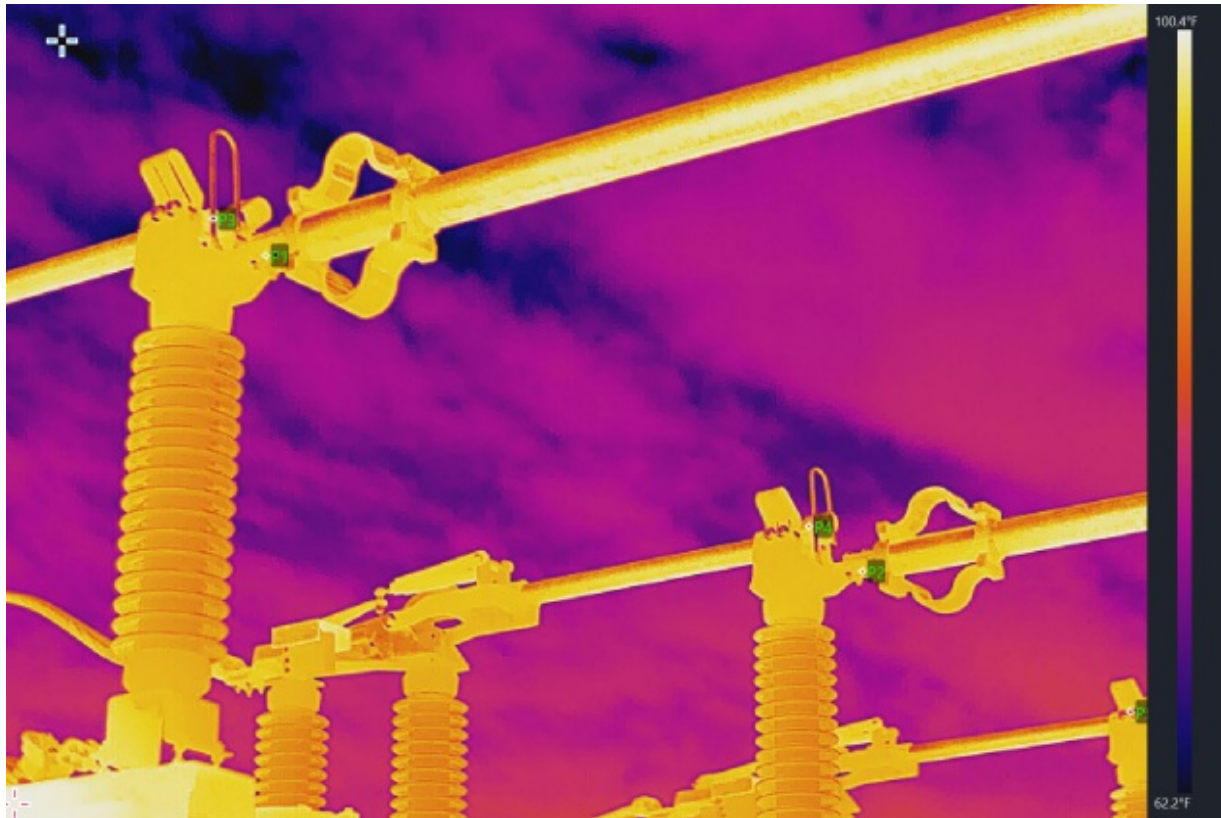

T1 - MAIN AIR SWITCH

Measurements		Image Parameters	
Image:Max. Temp.	100.4°F	Distance	1.5m
Image:Min. Temp.	62.2°F	Humidity	60%
P1	94.8°F	Emissivity	0.97
P2	90.1°F	Reflected Temp.	77.0°F
P3	80.4°F	Atmospheric Temp.	85.2°F
P4	93.0°F		
P5	87.8°F		

Measurement Parameters		Device Information	
P1:Emissivity	0.97	Device Model	SP60
P1:Reflected Temp.	77.0°F	Device Serial No.	L26310272
P1:Distance	1.5m	Captured At	2023-10-13 12:52:41
P2:Emissivity	0.97		
P2:Reflected Temp.	77.0°F		

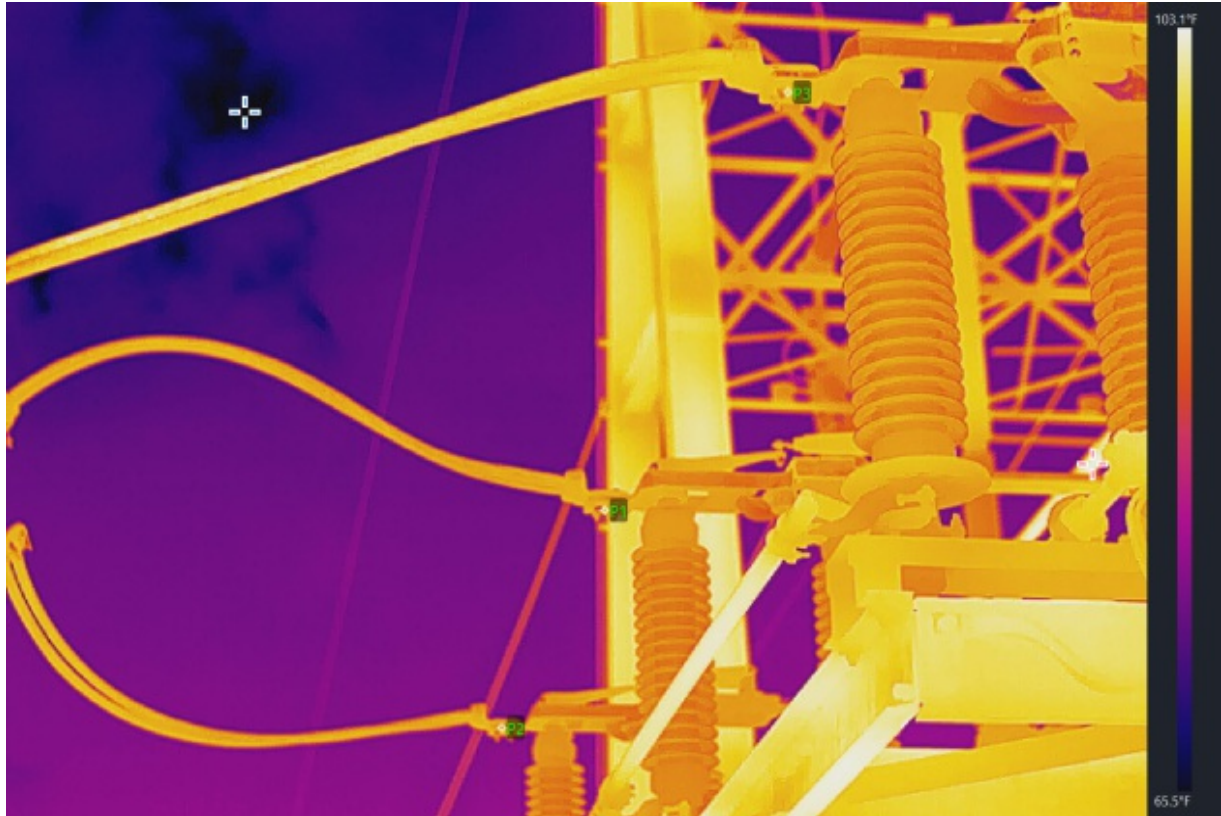

T1 - MAIN AIR SWITCH

Measurements		Image Parameters	
Image:Max. Temp.	103.1°F	Distance	1.5m
Image:Min. Temp.	65.5°F	Humidity	60%
P1	95.0°F	Emissivity	0.97
P2	93.6°F	Reflected Temp.	77.0°F
P3	95.5°F	Atmospheric Temp.	85.3°F

Measurement Parameters		Device Information	
P1:Emissivity	0.97	Device Model	SP60
P1:Reflected Temp.	77.0°F	Device Serial No.	L26310272
P1:Distance	1.5m	Captured At	2023-10-13 12:51:52
P2:Emissivity	0.97		
P2:Reflected Temp.	77.0°F		
P2:Distance	1.5m		
P3:Emissivity	0.97		

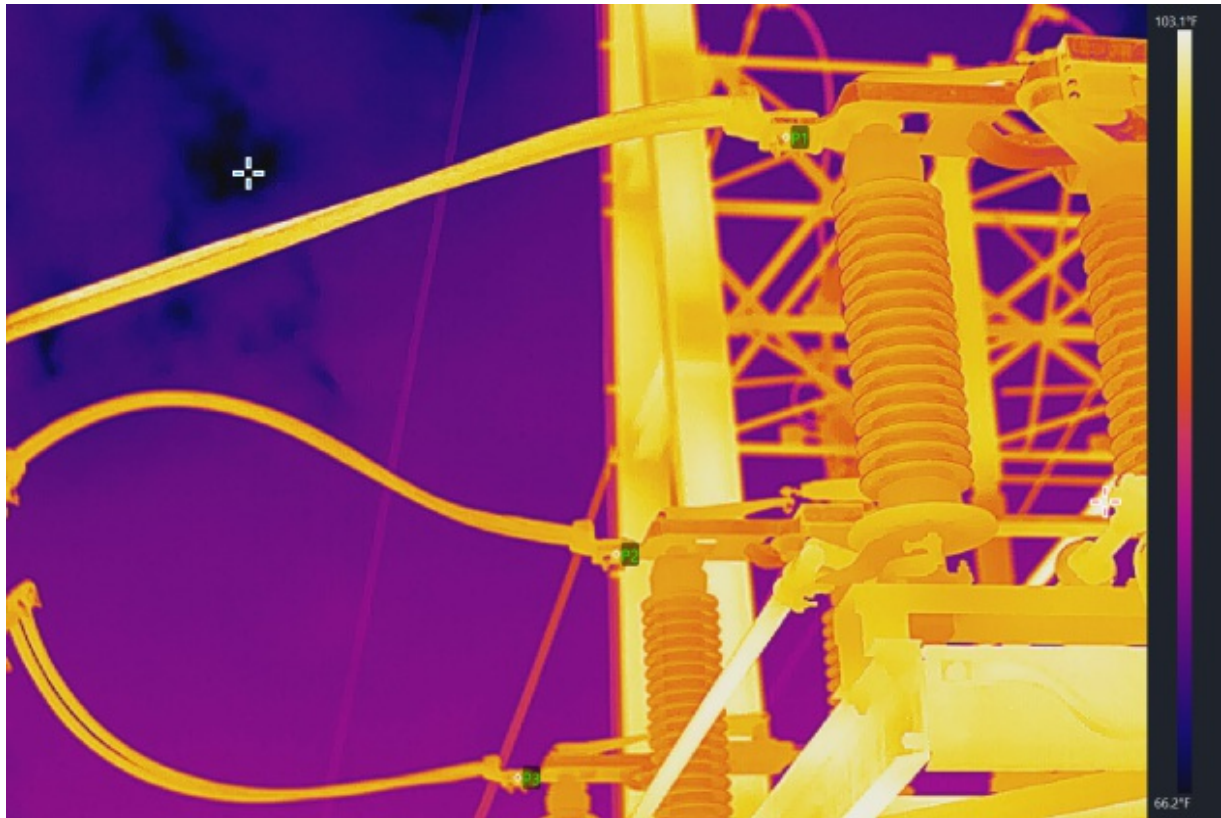

T1 - MAIN AIR SWITCH

Measurements		Image Parameters	
Image:Max. Temp.	103.1°F	Distance	1.5m
Image:Min. Temp.	66.2°F	Humidity	60%
P1	94.8°F	Emissivity	0.97
P2	94.8°F	Reflected Temp.	77.0°F
P3	92.3°F	Atmospheric Temp.	85.3°F

Measurement Parameters		Device Information	
P1:Emissivity	0.97	Device Model	SP60
P1:Reflected Temp.	77.0°F	Device Serial No.	L26310272
P1:Distance	1.5m	Captured At	2023-10-13 12:51:49
P2:Emissivity	0.97		
P2:Reflected Temp.	77.0°F		
P2:Distance	1.5m		
P3:Emissivity	0.97		

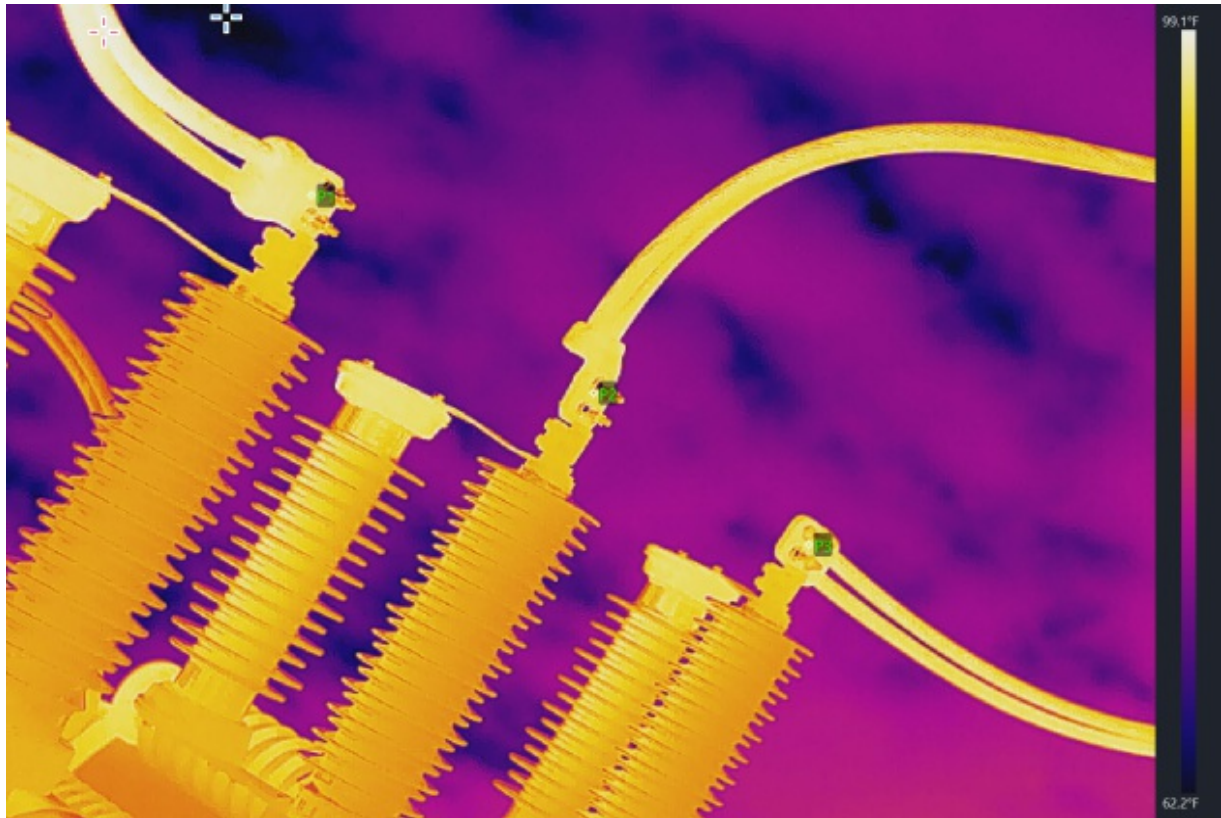

52-L1 - SF6 BREAKER

Measurements		Image Parameters	
Image:Max. Temp.	99.1°F	Distance	1.5m
Image:Min. Temp.	62.2°F	Humidity	60%
P1	95.7°F	Emissivity	0.97
P2	93.6°F	Reflected Temp.	77.0°F
P3	94.6°F	Atmospheric Temp.	85.2°F

Measurement Parameters		Device Information	
P1:Emissivity	0.97	Device Model	SP60
P1:Reflected Temp.	77.0°F	Device Serial No.	L26310272
P1:Distance	1.5m	Captured At	2023-10-13 12:51:05
P2:Emissivity	0.97		
P2:Reflected Temp.	77.0°F		
P2:Distance	1.5m		
P3:Emissivity	0.97		

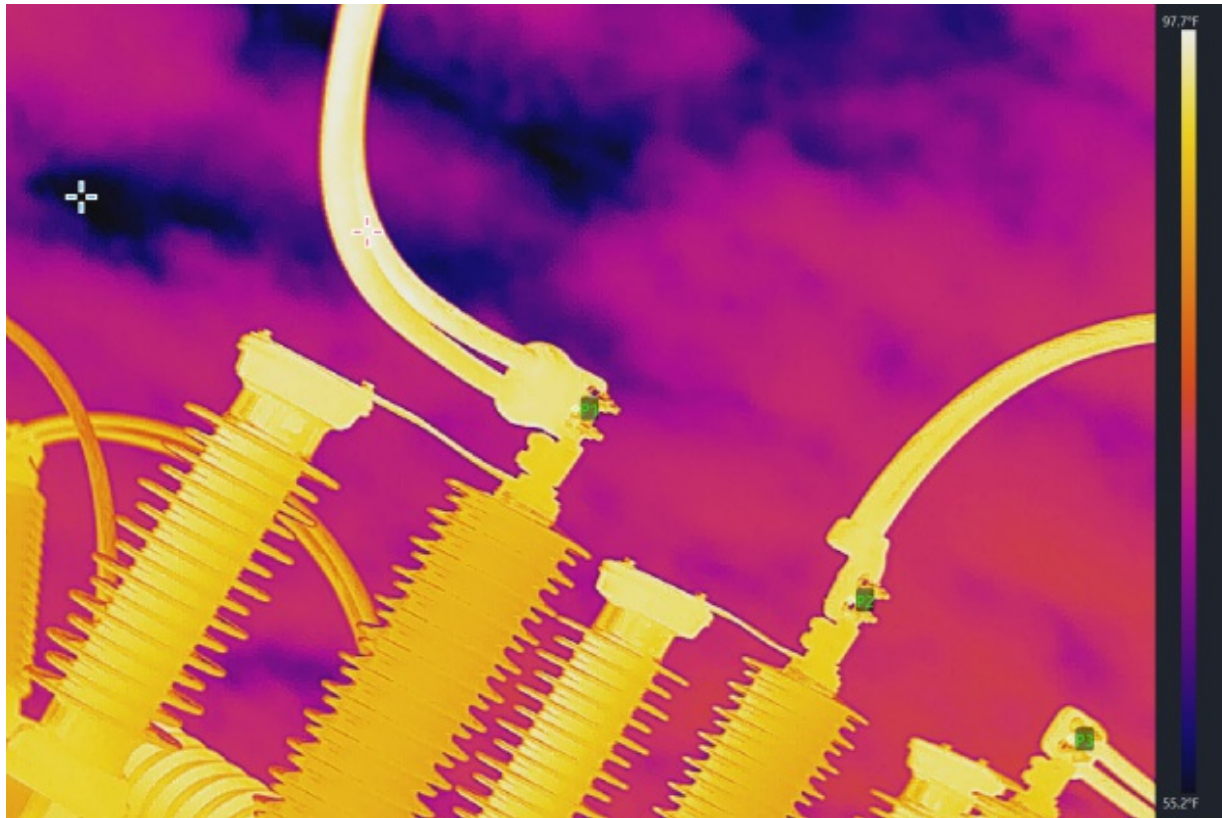

52-L1 - SF6 BREAKER

Measurements		Image Parameters	
Image:Max. Temp.	97.7°F	Distance	1.5m
Image:Min. Temp.	55.2°F	Humidity	60%
P1	94.5°F	Emissivity	0.97
P2	93.0°F	Reflected Temp.	77.0°F
P3	93.9°F	Atmospheric Temp.	85.2°F

Measurement Parameters		Device Information	
P1:Emissivity	0.97	Device Model	SP60
P1:Reflected Temp.	77.0°F	Device Serial No.	L26310272
P1:Distance	1.5m	Captured At	2023-10-13 12:50:34
P2:Emissivity	0.97		
P2:Reflected Temp.	77.0°F		
P2:Distance	1.5m		
P3:Emissivity	0.97		

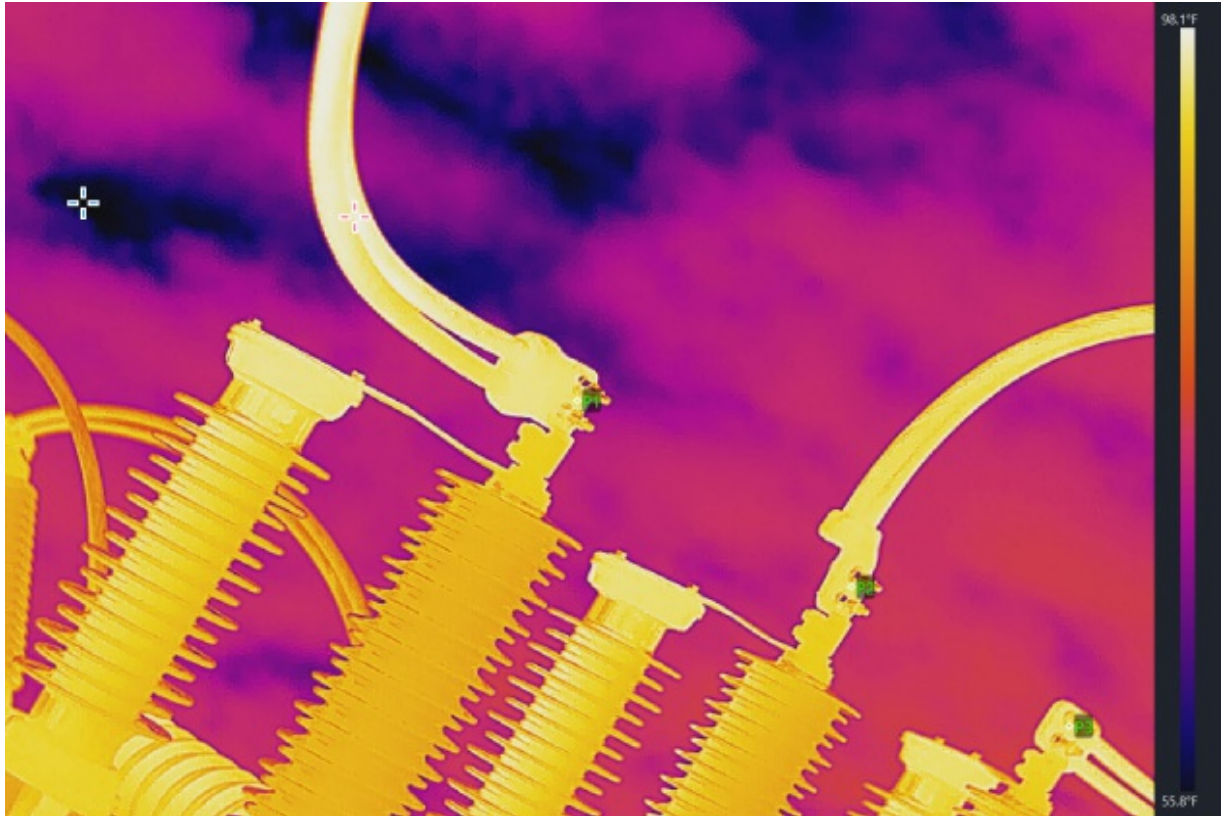

52-L1 - SF6 BREAKER

Measurements		Image Parameters	
Image:Max. Temp.	98.1°F	Distance	1.5m
Image:Min. Temp.	55.8°F	Humidity	60%
P1	94.5°F	Emissivity	0.97
P2	94.6°F	Reflected Temp.	77.0°F
P3	93.2°F	Atmospheric Temp.	85.2°F

Measurement Parameters		Device Information	
P1:Emissivity	0.97	Device Model	SP60
P1:Reflected Temp.	77.0°F	Device Serial No.	L26310272
P1:Distance	1.5m	Captured At	2023-10-13 12:50:32
P2:Emissivity	0.97		
P2:Reflected Temp.	77.0°F		
P2:Distance	1.5m		
P3:Emissivity	0.97		

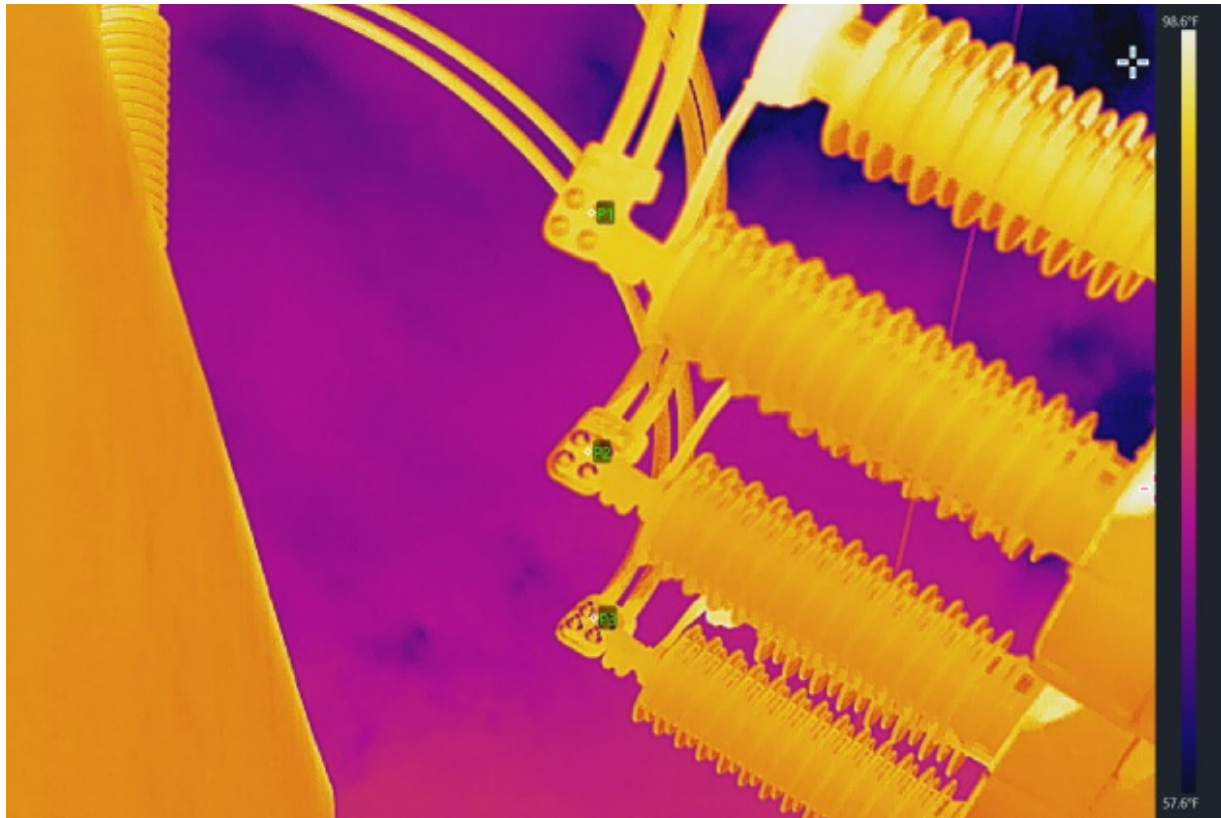

52-L1 - SF6 BREAKER

Measurements		Image Parameters	
Image:Max. Temp.	98.6°F	Distance	1.5m
Image:Min. Temp.	57.6°F	Humidity	60%
P1	91.2°F	Emissivity	0.97
P2	91.9°F	Reflected Temp.	77.0°F
P3	88.2°F	Atmospheric Temp.	86.2°F

Measurement Parameters		Device Information	
P1:Emissivity	0.97	Device Model	SP60
P1:Reflected Temp.	77.0°F	Device Serial No.	L26310272
P1:Distance	1.5m	Captured At	2023-10-13 12:50:21
P2:Emissivity	0.97		
P2:Reflected Temp.	77.0°F		
P2:Distance	1.5m		
P3:Emissivity	0.97		

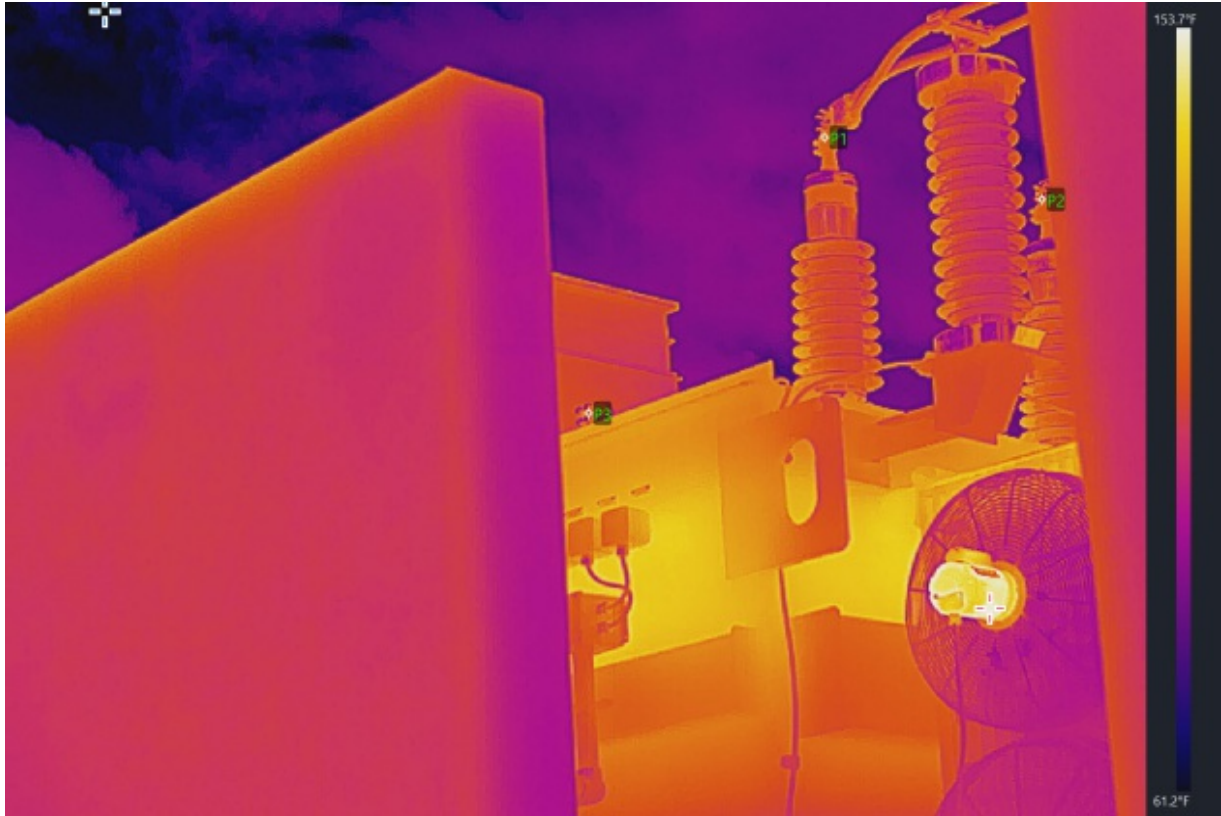

T1 - GSU - H0 BUSHING

Measurements		Image Parameters	
Image:Max. Temp.	153.7°F	Distance	1.5m
Image:Min. Temp.	61.2°F	Humidity	60%
P1	97.2°F	Emissivity	0.97
P2	94.6°F	Reflected Temp.	77.0°F
P3	95.7°F	Atmospheric Temp.	85.9°F

Measurement Parameters		Device Information	
P1:Emissivity	0.97	Device Model	SP60
P1:Reflected Temp.	77.0°F	Device Serial No.	L26310272
P1:Distance	1.5m	Captured At	2023-10-13 12:49:48
P2:Emissivity	0.97		
P2:Reflected Temp.	77.0°F		
P2:Distance	1.5m		
P3:Emissivity	0.97		



T1 - GSU - HIGH SIDE BUSHINGS

Measurements		Image Parameters	
Image:Max. Temp.	104.4°F	Distance	1.5m
Image:Min. Temp.	46.8°F	Humidity	60%
P1	96.8°F	Emissivity	0.97
P2	91.8°F	Reflected Temp.	77.0°F
P3	89.8°F	Atmospheric Temp.	87.3°F

Measurement Parameters		Device Information	
P1:Emissivity	0.97	Device Model	SP60
P1:Reflected Temp.	77.0°F	Device Serial No.	L26310272
P1:Distance	1.5m	Captured At	2023-10-13 12:48:52
P2:Emissivity	0.97		
P2:Reflected Temp.	77.0°F		
P2:Distance	1.5m		
P3:Emissivity	0.97		



T1 - GSU - HIGH SIDE BUSHINGS

Measurements		Image Parameters	
Image:Max. Temp.	109.4°F	Distance	1.5m
Image:Min. Temp.	64.2°F	Humidity	60%
P1	95.9°F	Emissivity	0.97
P2	97.2°F	Reflected Temp.	77.0°F
		Atmospheric Temp.	86.9°F

Measurement Parameters		Device Information	
P1:Emissivity	0.97	Device Model	SP60
P1:Reflected Temp.	77.0°F	Device Serial No.	L26310272
P1:Distance	1.5m	Captured At	2023-10-13 12:48:21
P2:Emissivity	0.97		
P2:Reflected Temp.	77.0°F		
P2:Distance	1.5m		



Orange Cogen
Test Reports
Pre-Outage - IR Scanning
Job #OCFL2310067



Empowering Electrical Infrastructure
for a Sustainable Future



Testing and Commissioning Services

6625 Network Way, Indianapolis, IN 46278

www.hva-inc.com/pc-field-services/

Equipment Tested: Switch-yard and buss duct

Scope of Work: IR scan Pre-outage

Observations and Recommendations:

Results: Good - no hot spots

Thermography Report

Client	Orange Cogen
Address	Bartow, Florida
Date	8/4/2023
Inspector	Andrew Kirk

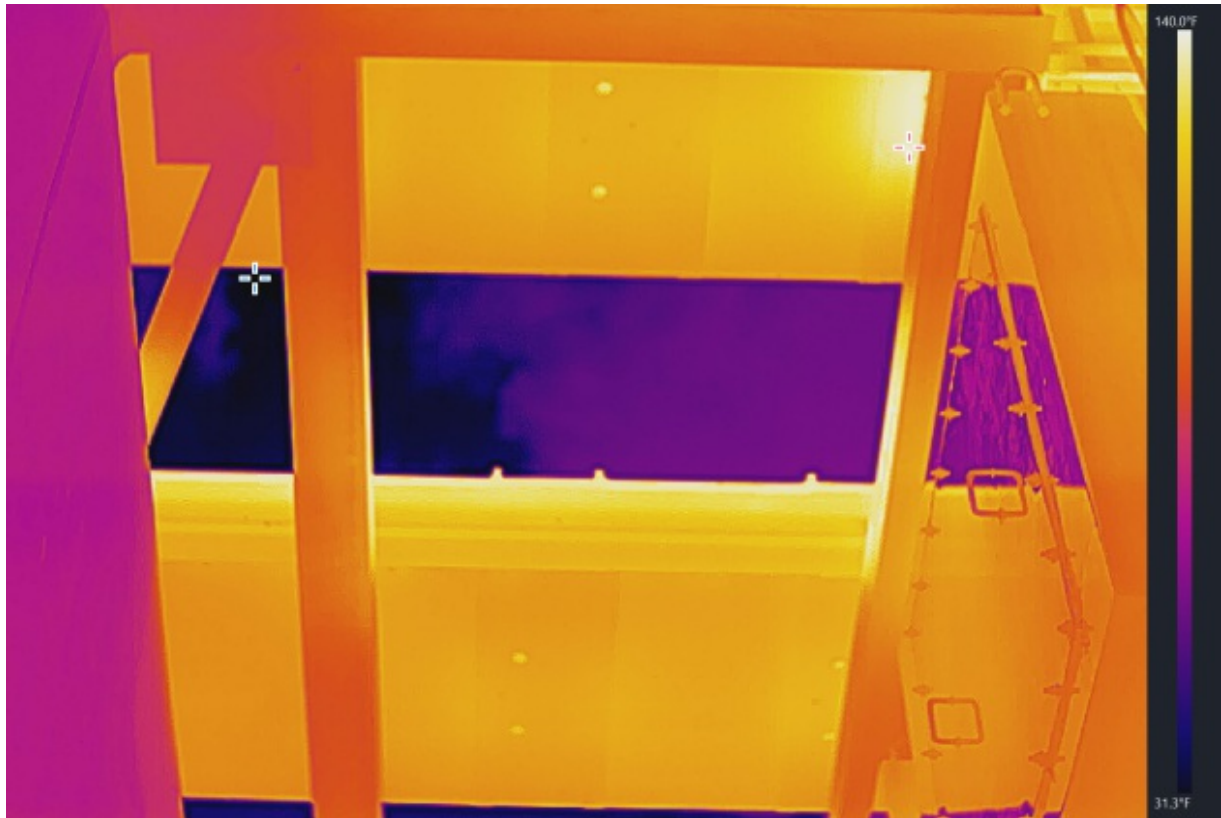

BUS DUCT HEATERS

Measurements		Image Parameters	
Image:Max. Temp.	140.0°F	Distance	1.5m
Image:Min. Temp.	31.3°F	Humidity	60%
		Emissivity	0.97
		Reflected Temp.	77.0°F
		Atmospheric Temp.	92.0°F
Measurement Parameters		Device Information	
		Device Model	SP60
		Device Serial No.	L26310272
		Captured At	2023-08-04 03:08:58
Text Annotation			

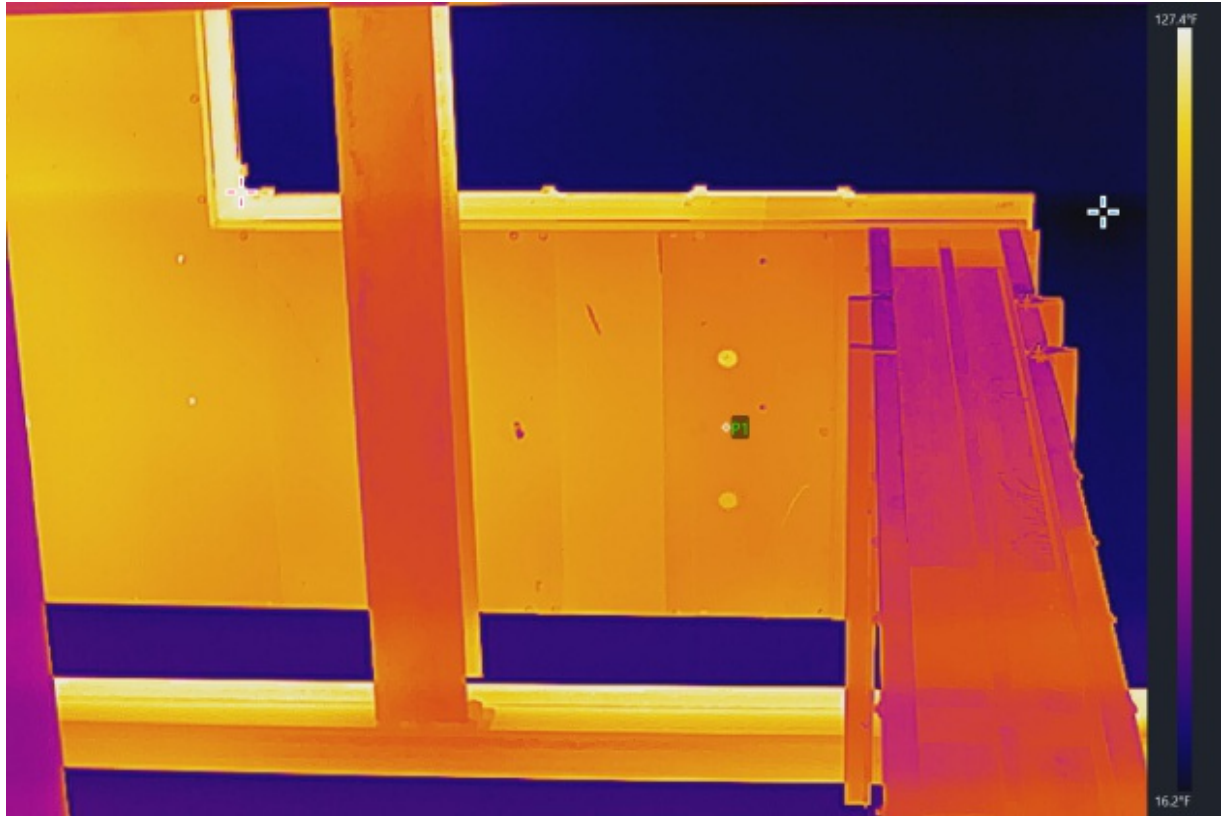

BUS DUCT HEATERS

Measurements		Image Parameters	
Image:Max. Temp.	127.4°F	Distance	1.5m
Image:Min. Temp.	16.2°F	Humidity	60%
P1	105.6°F	Emissivity	0.97
		Reflected Temp.	77.0°F
		Atmospheric Temp.	91.8°F

Measurement Parameters		Device Information	
P1:Emissivity	0.97	Device Model	SP60
P1:Reflected Temp.	77.0°F	Device Serial No.	L26310272
P1:Distance	1.5m	Captured At	2023-08-04 03:08:04

Text Annotation

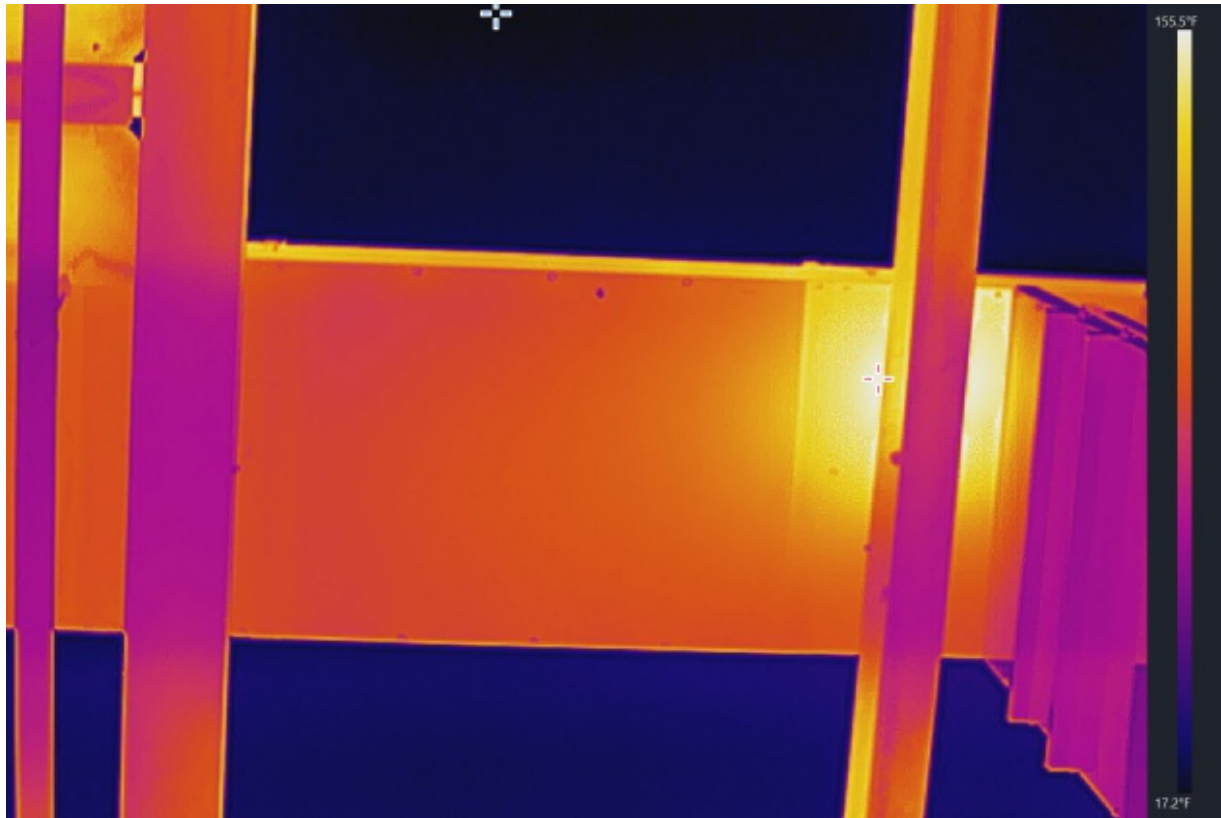

BUS DUCT HEATERS

Measurements		Image Parameters	
Image:Max. Temp.	155.5°F	Distance	1.5m
Image:Min. Temp.	17.2°F	Humidity	60%
		Emissivity	0.97
		Reflected Temp.	77.0°F
		Atmospheric Temp.	91.7°F
Measurement Parameters		Device Information	
		Device Model	SP60
		Device Serial No.	L26310272
		Captured At	2023-08-04 03:07:25
Text Annotation			

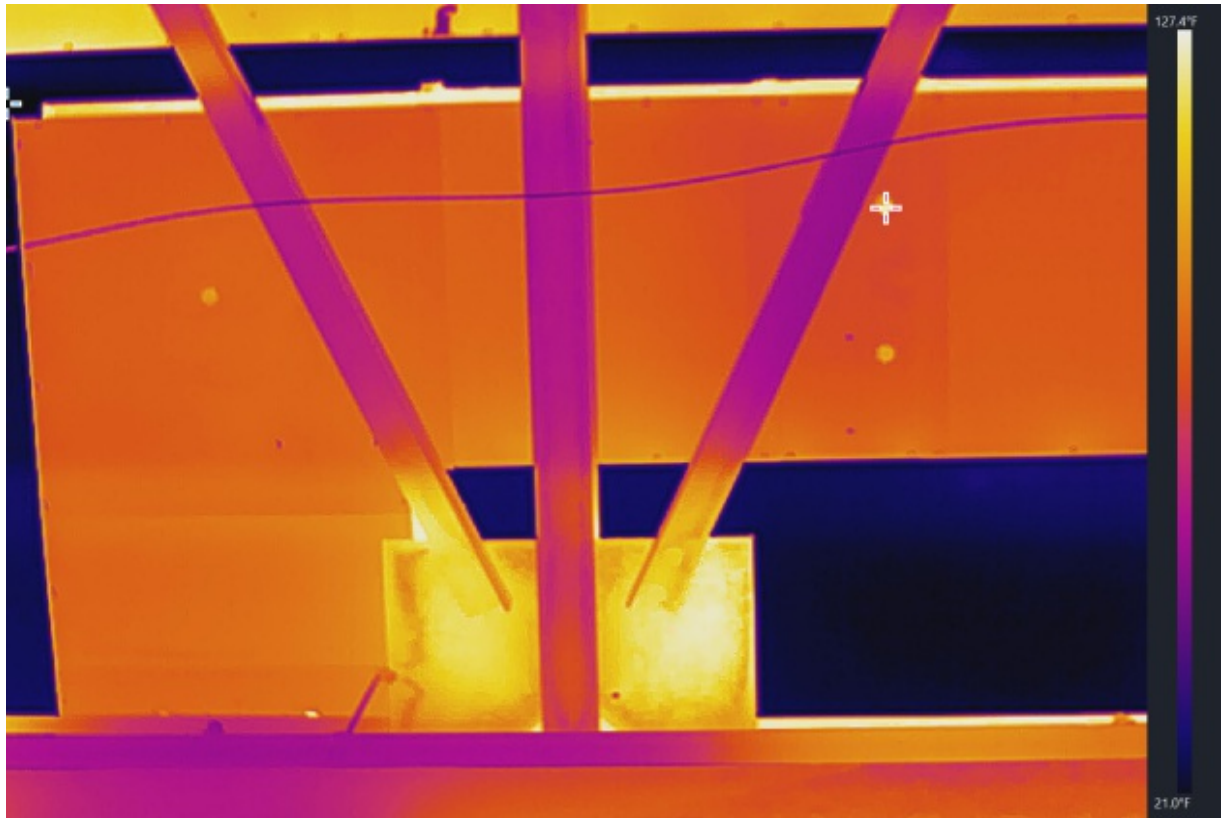

BUS DUCT HEATERS

Measurements		Image Parameters	
Image:Max. Temp.	127.4°F	Distance	1.5m
Image:Min. Temp.	21.0°F	Humidity	60%
		Emissivity	0.97
		Reflected Temp.	77.0°F
		Atmospheric Temp.	91.8°F
Measurement Parameters		Device Information	
		Device Model	SP60
		Device Serial No.	L26310272
		Captured At	2023-08-04 03:07:12
Text Annotation			

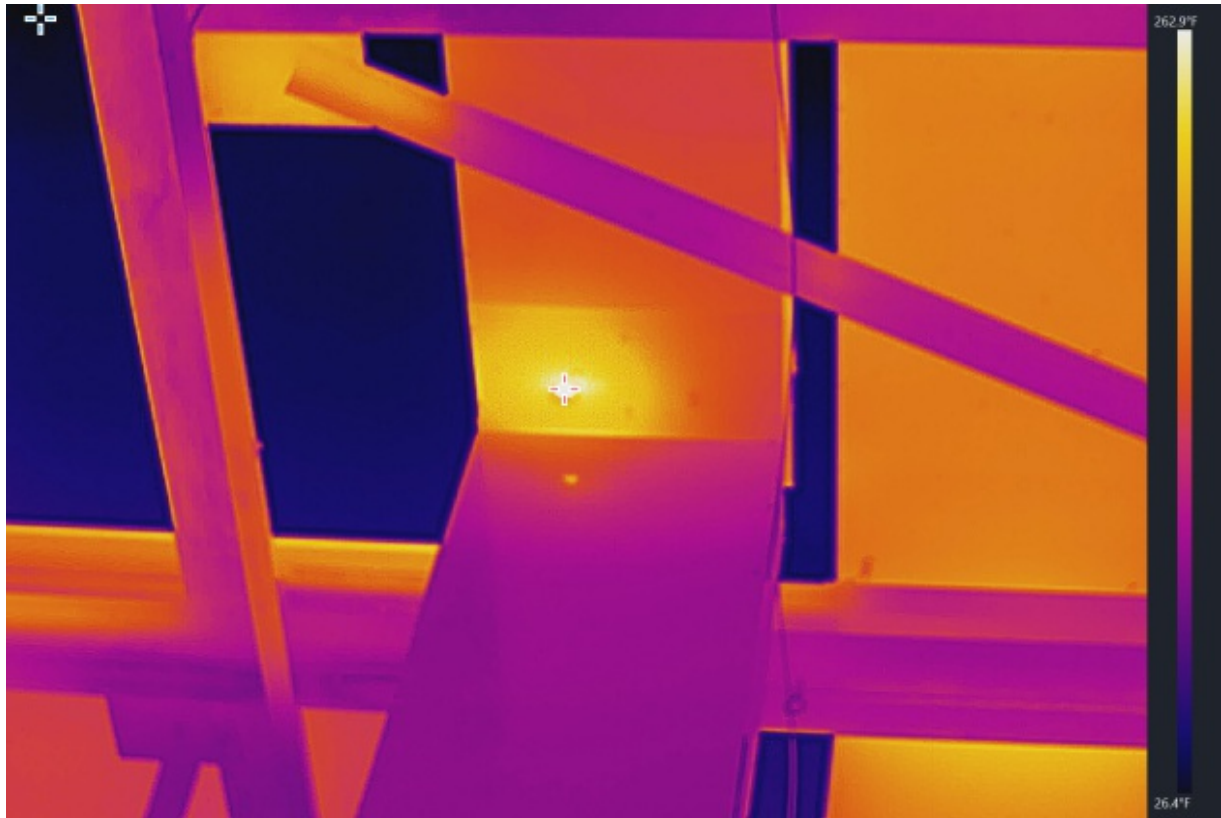

BUS DUCT HEATERS

Measurements		Image Parameters	
Image:Max. Temp.	262.9°F	Distance	1.5m
Image:Min. Temp.	26.4°F	Humidity	60%
		Emissivity	0.97
		Reflected Temp.	77.0°F
		Atmospheric Temp.	91.9°F
Measurement Parameters		Device Information	
		Device Model	SP60
		Device Serial No.	L26310272
		Captured At	2023-08-04 03:07:02
Text Annotation			

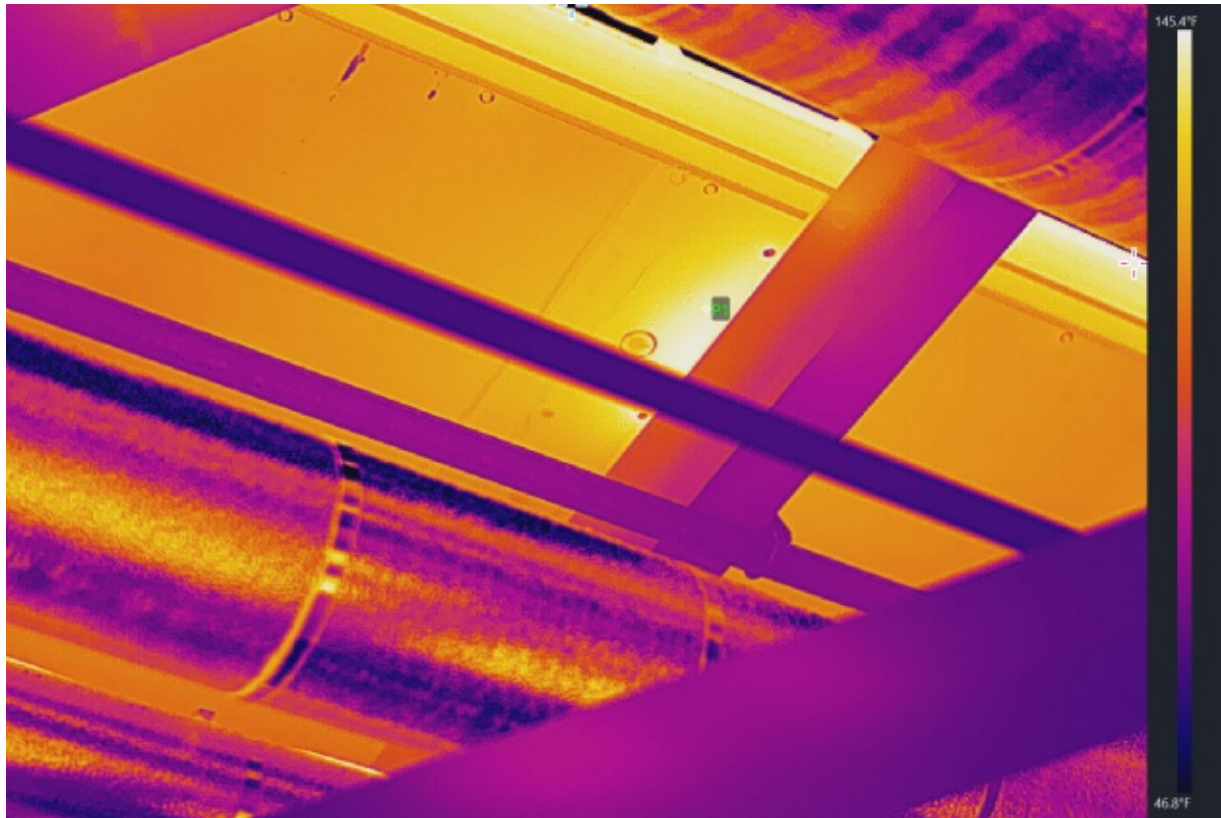

BUS DUCT HEATERS

Measurements		Image Parameters	
Image:Max. Temp.	145.4°F	Distance	1.5m
Image:Min. Temp.	46.8°F	Humidity	60%
P1	140.7°F	Emissivity	0.97
		Reflected Temp.	77.0°F
		Atmospheric Temp.	92.2°F

Measurement Parameters		Device Information	
P1:Emissivity	0.97	Device Model	SP60
P1:Reflected Temp.	77.0°F	Device Serial No.	L26310272
P1:Distance	1.5m	Captured At	2023-08-04 03:04:34

Text Annotation

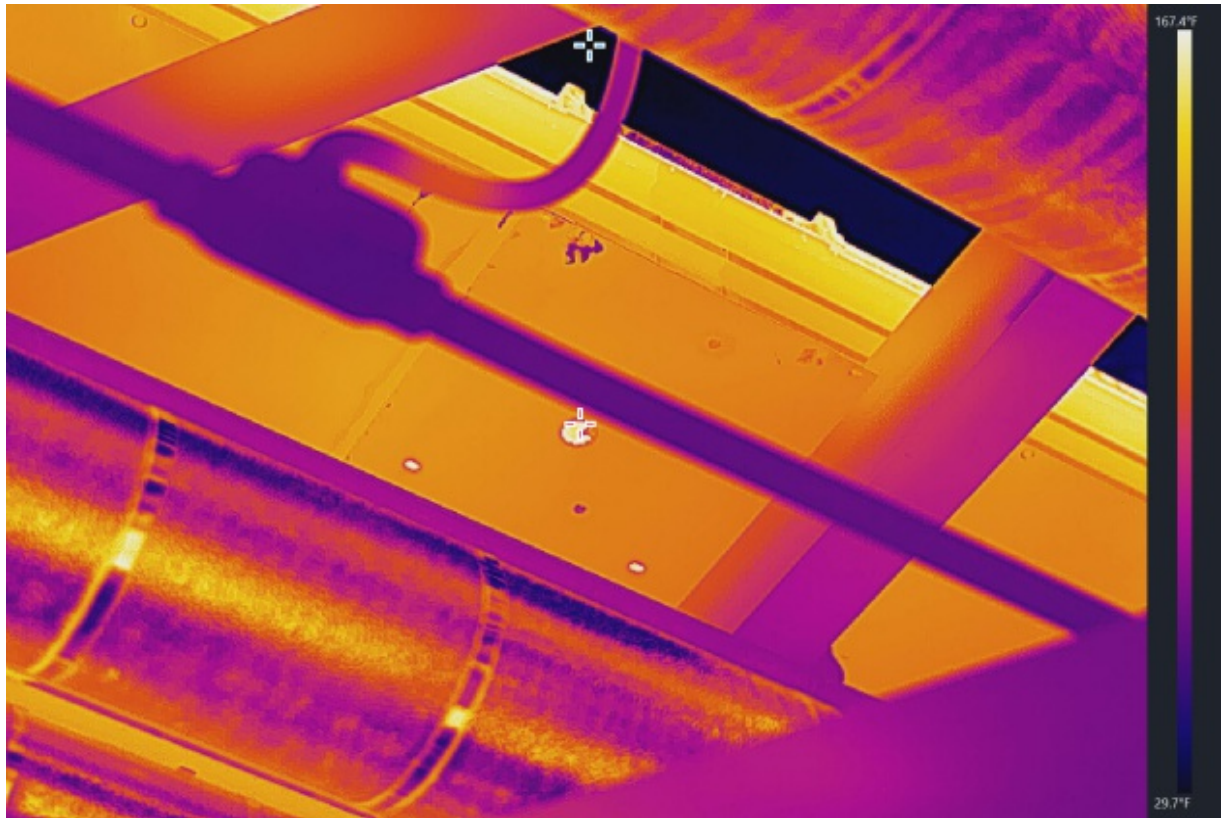

BUS DUCT HEATERS

Measurements		Image Parameters	
Image:Max. Temp.	167.4°F	Distance	1.5m
Image:Min. Temp.	29.7°F	Humidity	60%
		Emissivity	0.97
		Reflected Temp.	77.0°F
		Atmospheric Temp.	92.0°F
Measurement Parameters		Device Information	
		Device Model	SP60
		Device Serial No.	L26310272
		Captured At	2023-08-04 03:04:13
Text Annotation			

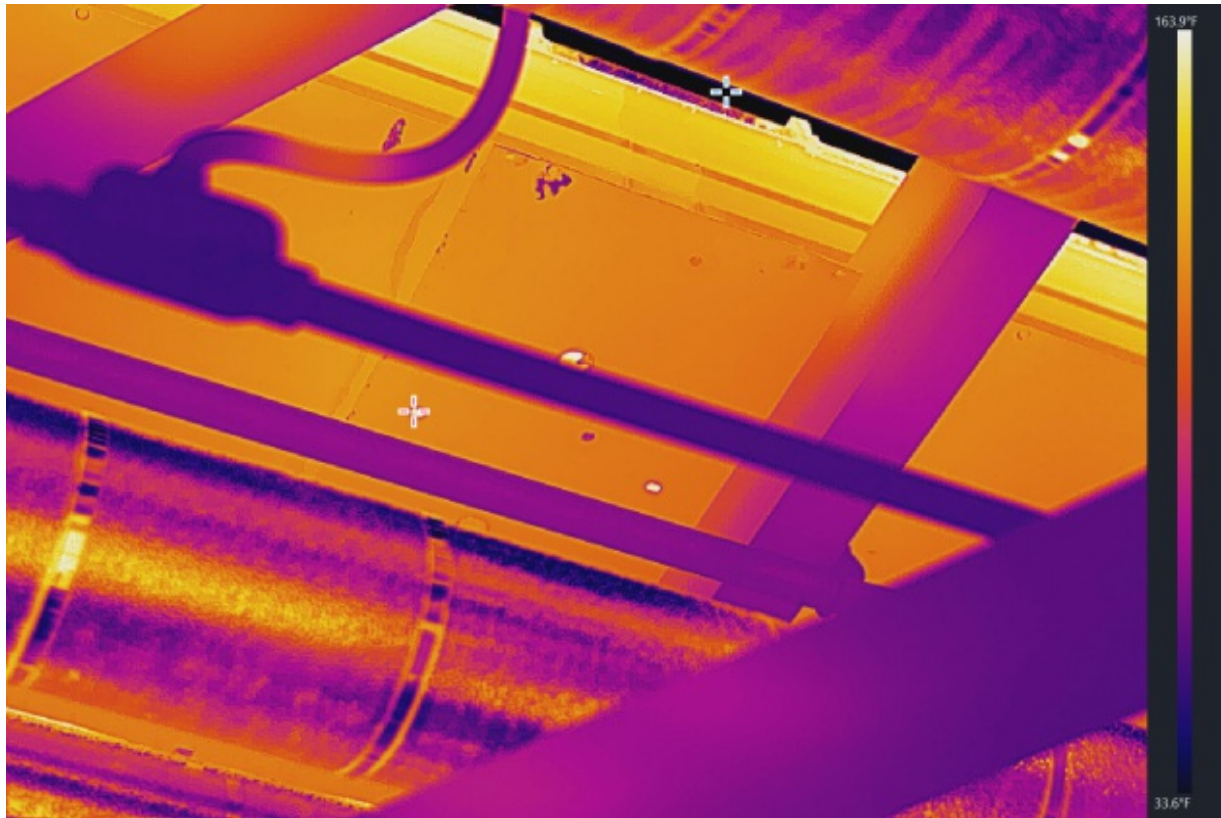

BUS DUCT HEATERS

Measurements		Image Parameters	
Image:Max. Temp.	163.9°F	Distance	1.5m
Image:Min. Temp.	33.6°F	Humidity	60%
		Emissivity	0.97
		Reflected Temp.	77.0°F
		Atmospheric Temp.	91.9°F
Measurement Parameters		Device Information	
		Device Model	SP60
		Device Serial No.	L26310272
		Captured At	2023-08-04 03:04:07
Text Annotation			

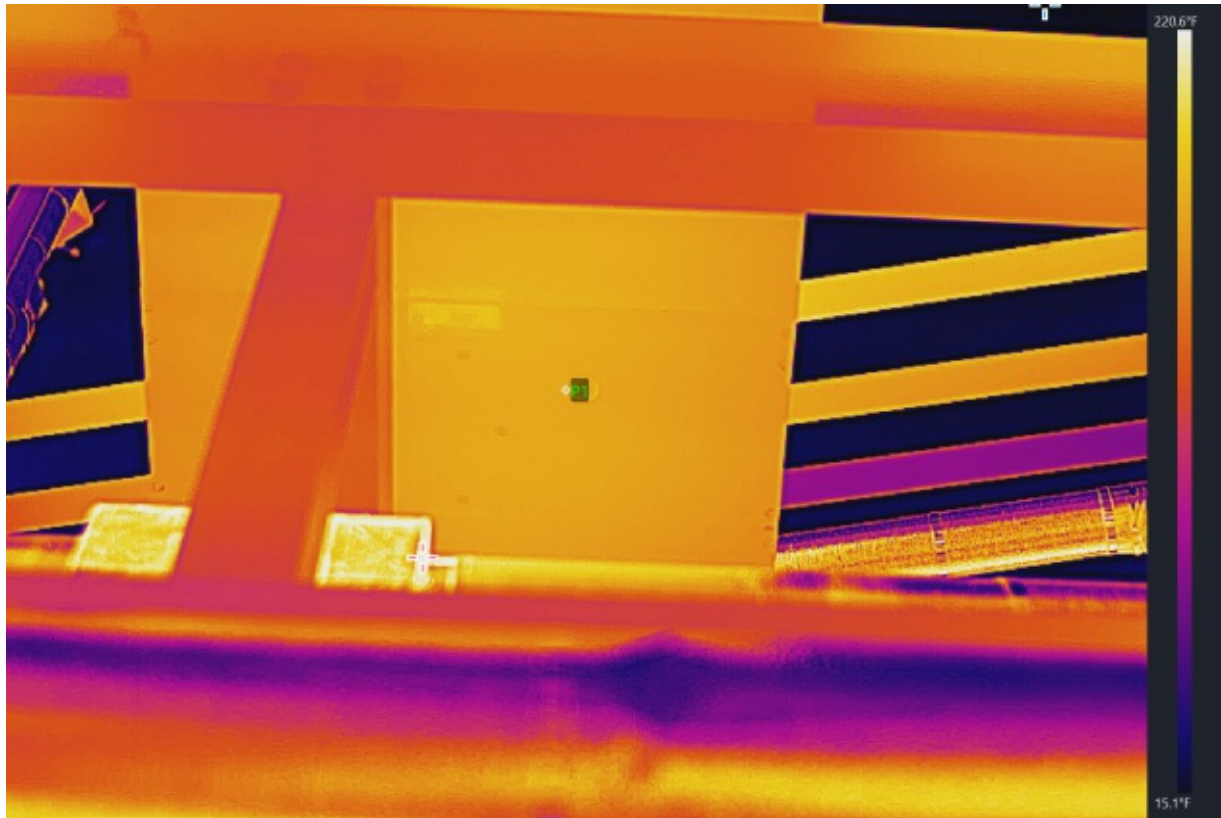

BUS DUCT HEATERS

Measurements		Image Parameters	
Image:Max. Temp.	220.6°F	Distance	1.5m
Image:Min. Temp.	15.1°F	Humidity	60%
P1	118.0°F	Emissivity	0.97
		Reflected Temp.	77.0°F
		Atmospheric Temp.	91.4°F

Measurement Parameters		Device Information	
P1:Emissivity	0.97	Device Model	SP60
P1:Reflected Temp.	77.0°F	Device Serial No.	L26310272
P1:Distance	1.5m	Captured At	2023-08-04 03:03:18

Text Annotation

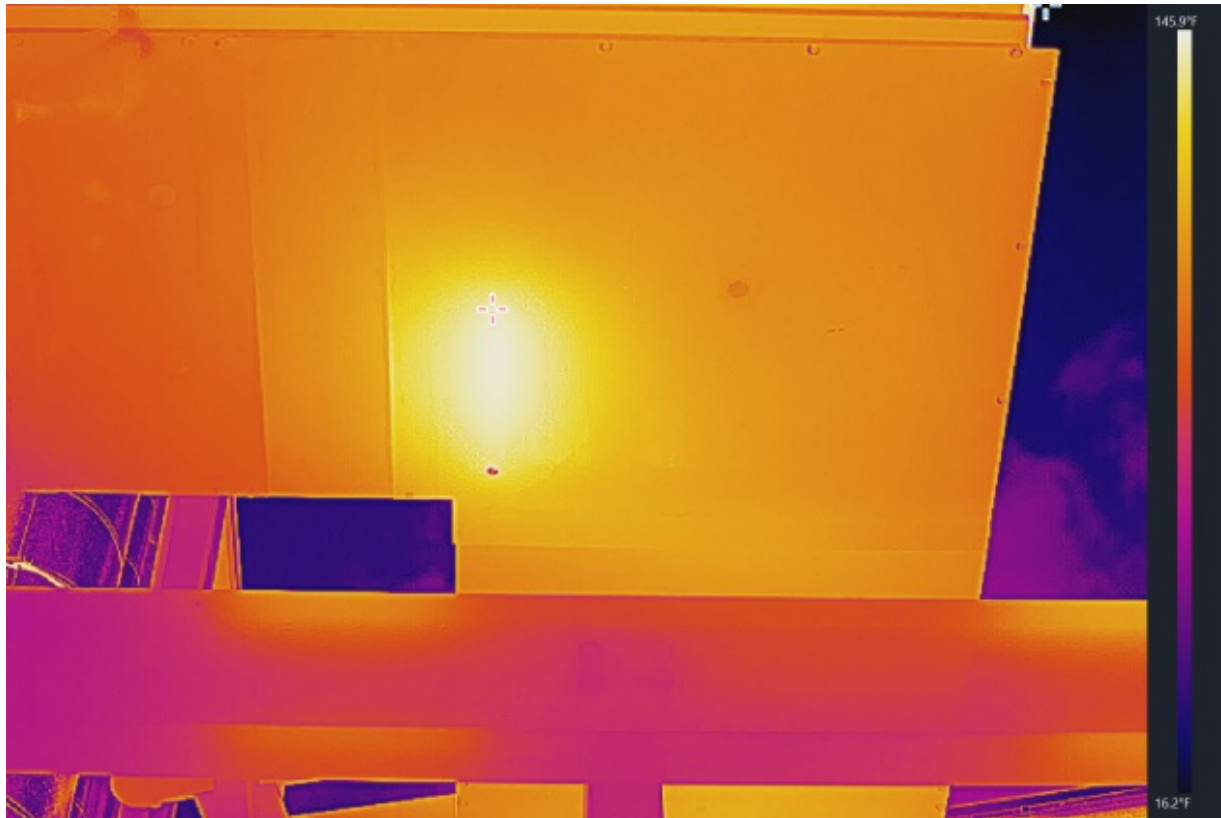

BUS DUCT HEATERS

Measurements		Image Parameters	
Image:Max. Temp.	145.9°F	Distance	1.5m
Image:Min. Temp.	16.2°F	Humidity	60%
		Emissivity	0.97
		Reflected Temp.	77.0°F
		Atmospheric Temp.	91.4°F
Measurement Parameters		Device Information	
		Device Model	SP60
		Device Serial No.	L26310272
		Captured At	2023-08-04 03:03:04
Text Annotation			

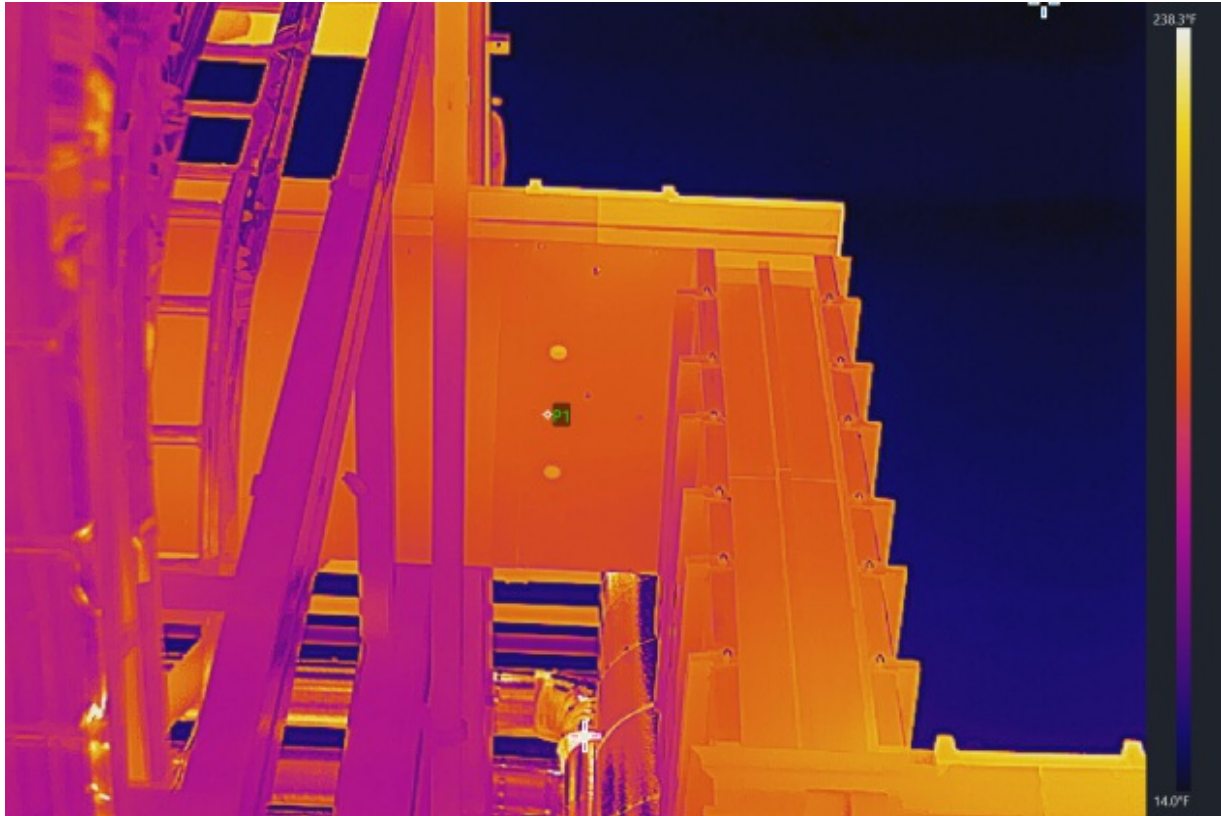

BUS DUCT HEATERS

Measurements		Image Parameters	
Image:Max. Temp.	238.3°F	Distance	1.5m
Image:Min. Temp.	14.0°F	Humidity	60%
P1	104.5°F	Emissivity	0.97
		Reflected Temp.	77.0°F
		Atmospheric Temp.	91.4°F

Measurement Parameters		Device Information	
P1:Emissivity	0.97	Device Model	SP60
P1:Reflected Temp.	77.0°F	Device Serial No.	L26310272
P1:Distance	1.5m	Captured At	2023-08-04 03:02:45

Text Annotation

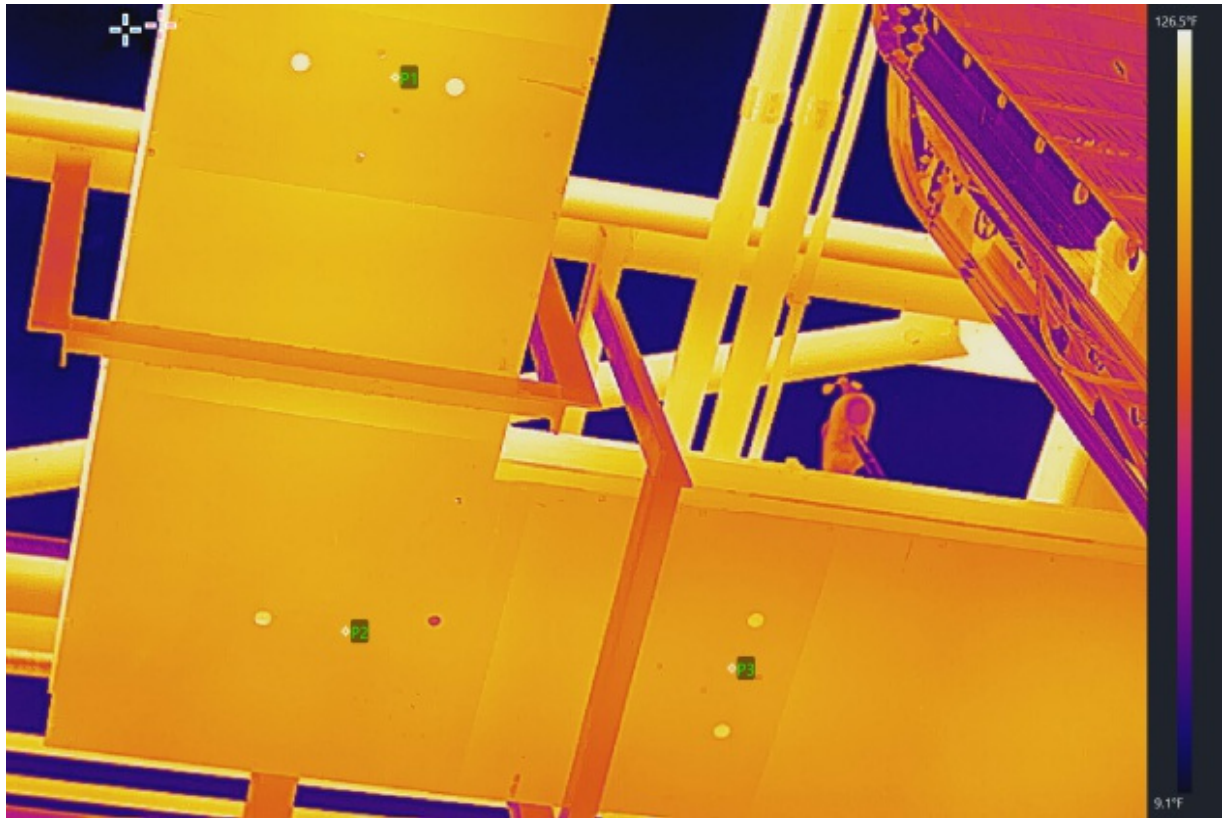

BUS DUCT HEATERS

Measurements		Image Parameters	
Image:Max. Temp.	126.5°F	Distance	1.5m
Image:Min. Temp.	9.1°F	Humidity	60%
P1	110.3°F	Emissivity	0.97
P2	107.4°F	Reflected Temp.	77.0°F
P3	106.5°F	Atmospheric Temp.	91.4°F

Measurement Parameters		Device Information	
P1:Emissivity	0.97	Device Model	SP60
P1:Reflected Temp.	77.0°F	Device Serial No.	L26310272
P1:Distance	1.5m	Captured At	2023-08-04 03:02:32
P2:Emissivity	0.97		
P2:Reflected Temp.	77.0°F		
P2:Distance	1.5m		
P3:Emissivity	0.97		

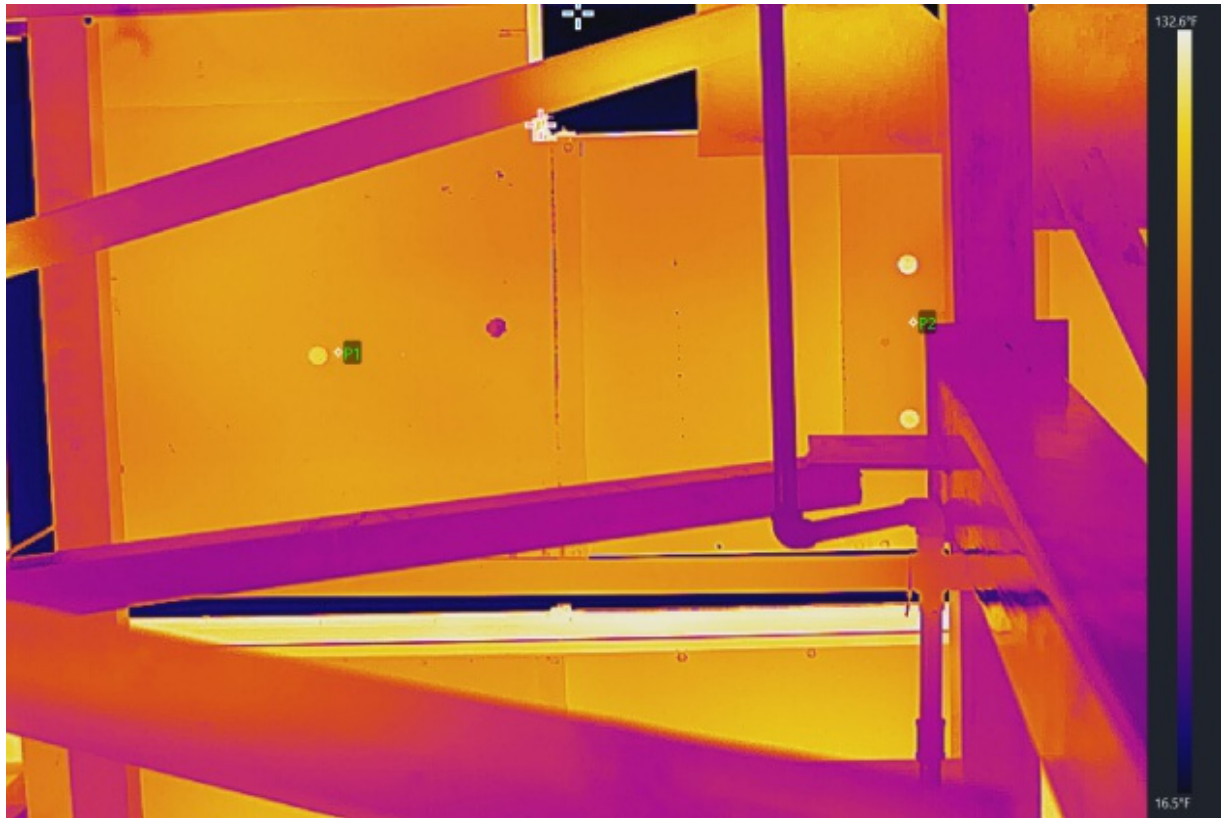

BUS DUCT HEATERS

Measurements		Image Parameters	
Image:Max. Temp.	132.6°F	Distance	1.5m
Image:Min. Temp.	16.5°F	Humidity	60%
P1	111.7°F	Emissivity	0.97
P2	109.6°F	Reflected Temp.	77.0°F
		Atmospheric Temp.	91.5°F

Measurement Parameters		Device Information	
P1:Emissivity	0.97	Device Model	SP60
P1:Reflected Temp.	77.0°F	Device Serial No.	L26310272
P1:Distance	1.5m	Captured At	2023-08-04 03:02:20
P2:Emissivity	0.97		
P2:Reflected Temp.	77.0°F		
P2:Distance	1.5m		

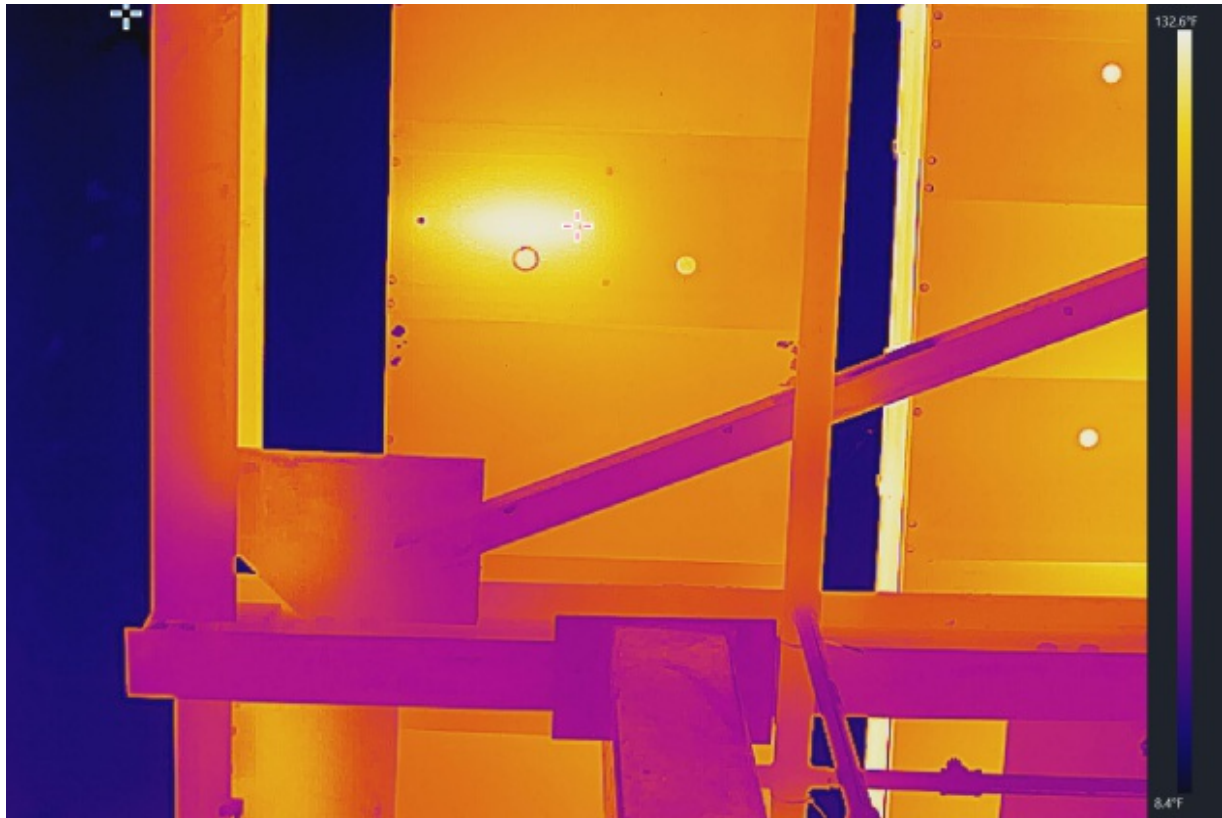

BUS DUCT HEATERS

Measurements		Image Parameters	
Image:Max. Temp.	132.6°F	Distance	1.5m
Image:Min. Temp.	8.4°F	Humidity	60%
		Emissivity	0.97
		Reflected Temp.	77.0°F
		Atmospheric Temp.	91.5°F
Measurement Parameters		Device Information	
		Device Model	SP60
		Device Serial No.	L26310272
		Captured At	2023-08-04 03:02:09
Text Annotation			

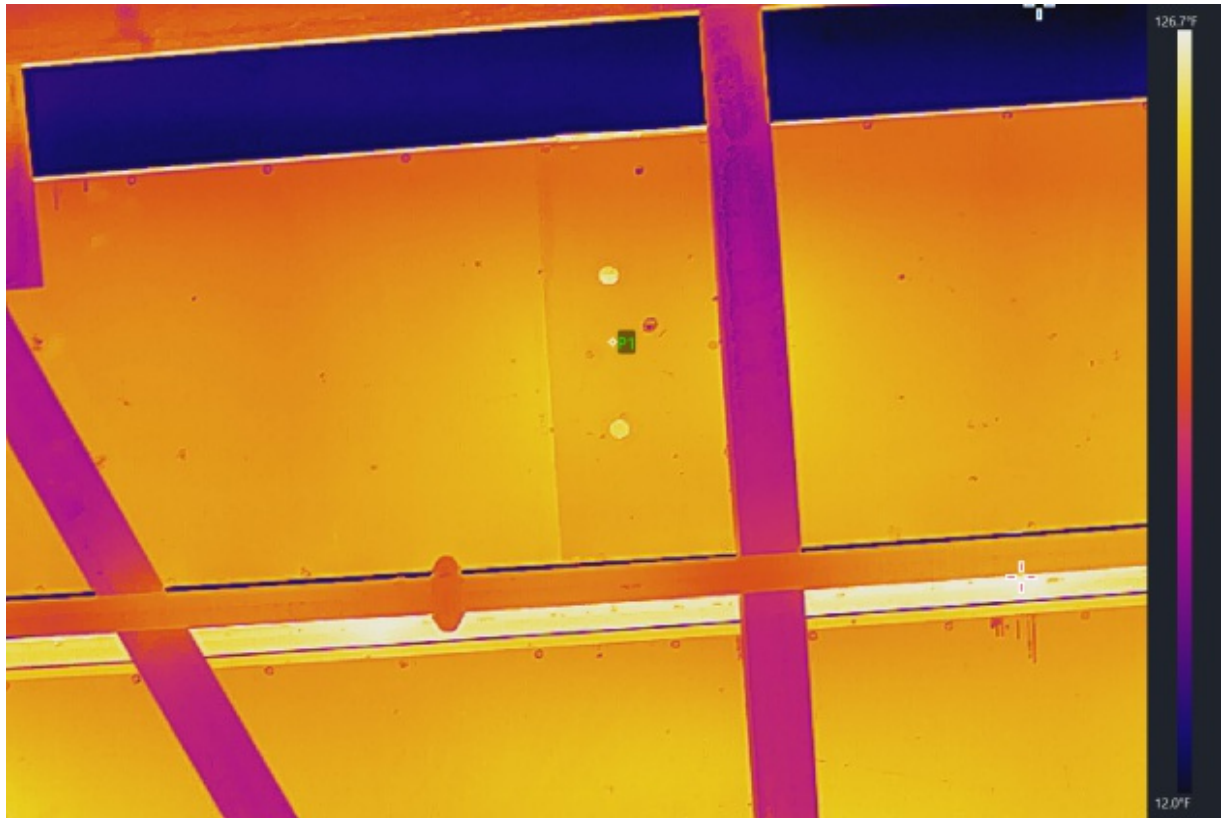

BUS DUCT HEATERS

Measurements		Image Parameters	
Image:Max. Temp.	126.7°F	Distance	1.5m
Image:Min. Temp.	12.0°F	Humidity	60%
P1	114.4°F	Emissivity	0.97
		Reflected Temp.	77.0°F
		Atmospheric Temp.	91.5°F

Measurement Parameters		Device Information	
P1:Emissivity	0.97	Device Model	SP60
P1:Reflected Temp.	77.0°F	Device Serial No.	L26310272
P1:Distance	1.5m	Captured At	2023-08-04 03:02:00

Text Annotation

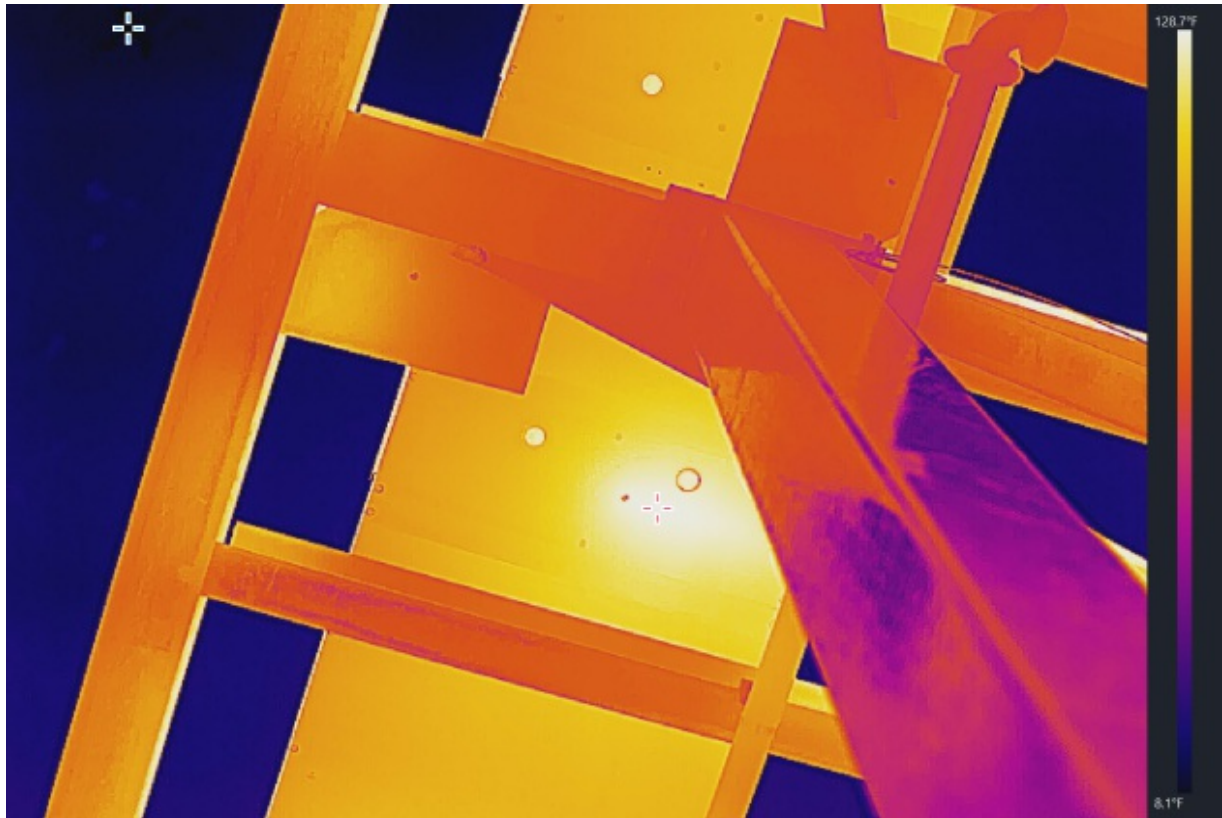

BUS DUCT HEATERS

Measurements		Image Parameters	
Image:Max. Temp.	128.7°F	Distance	1.5m
Image:Min. Temp.	8.1°F	Humidity	60%
		Emissivity	0.97
		Reflected Temp.	77.0°F
		Atmospheric Temp.	91.6°F
Measurement Parameters		Device Information	
		Device Model	SP60
		Device Serial No.	L26310272
		Captured At	2023-08-04 03:01:47
Text Annotation			

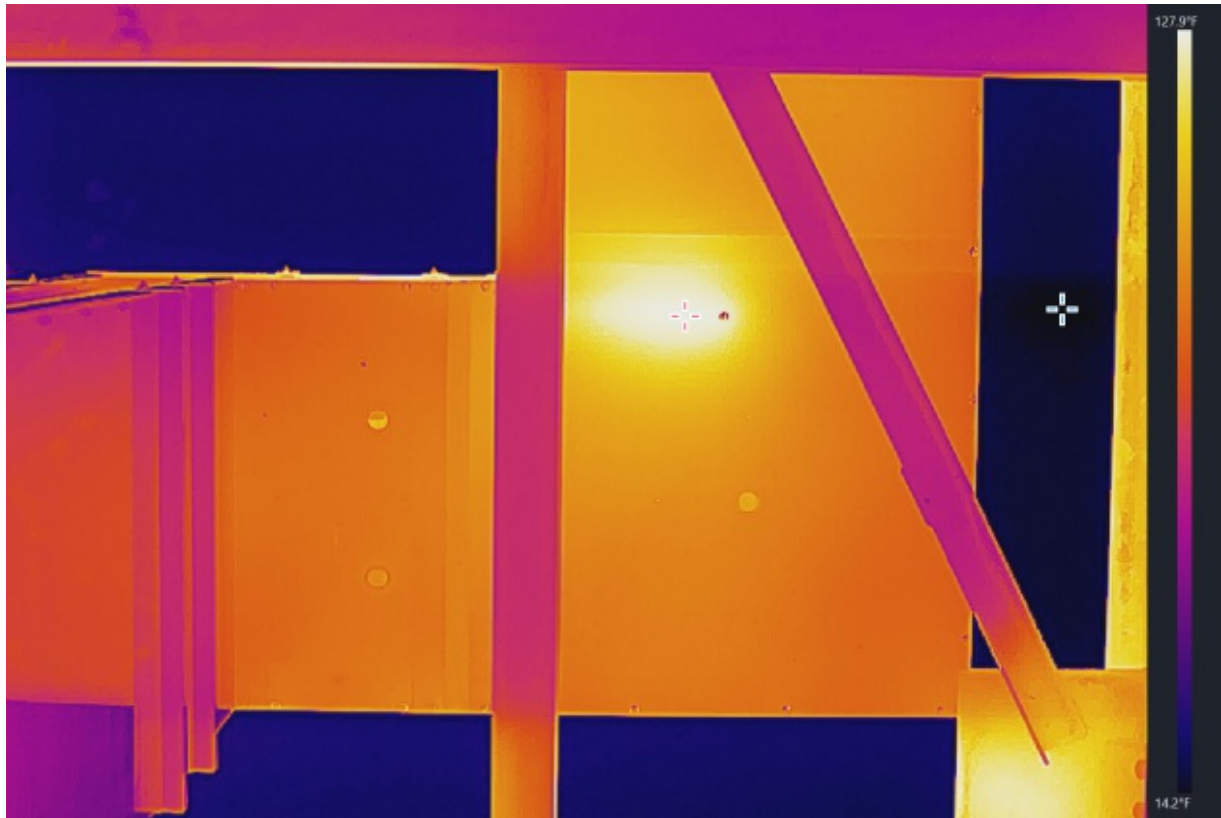

BUS DUCT HEATERS

Measurements		Image Parameters	
Image:Max. Temp.	127.9°F	Distance	1.5m
Image:Min. Temp.	14.2°F	Humidity	60%
		Emissivity	0.97
		Reflected Temp.	77.0°F
		Atmospheric Temp.	91.5°F
Measurement Parameters		Device Information	
		Device Model	SP60
		Device Serial No.	L26310272
		Captured At	2023-08-04 03:01:34
Text Annotation			

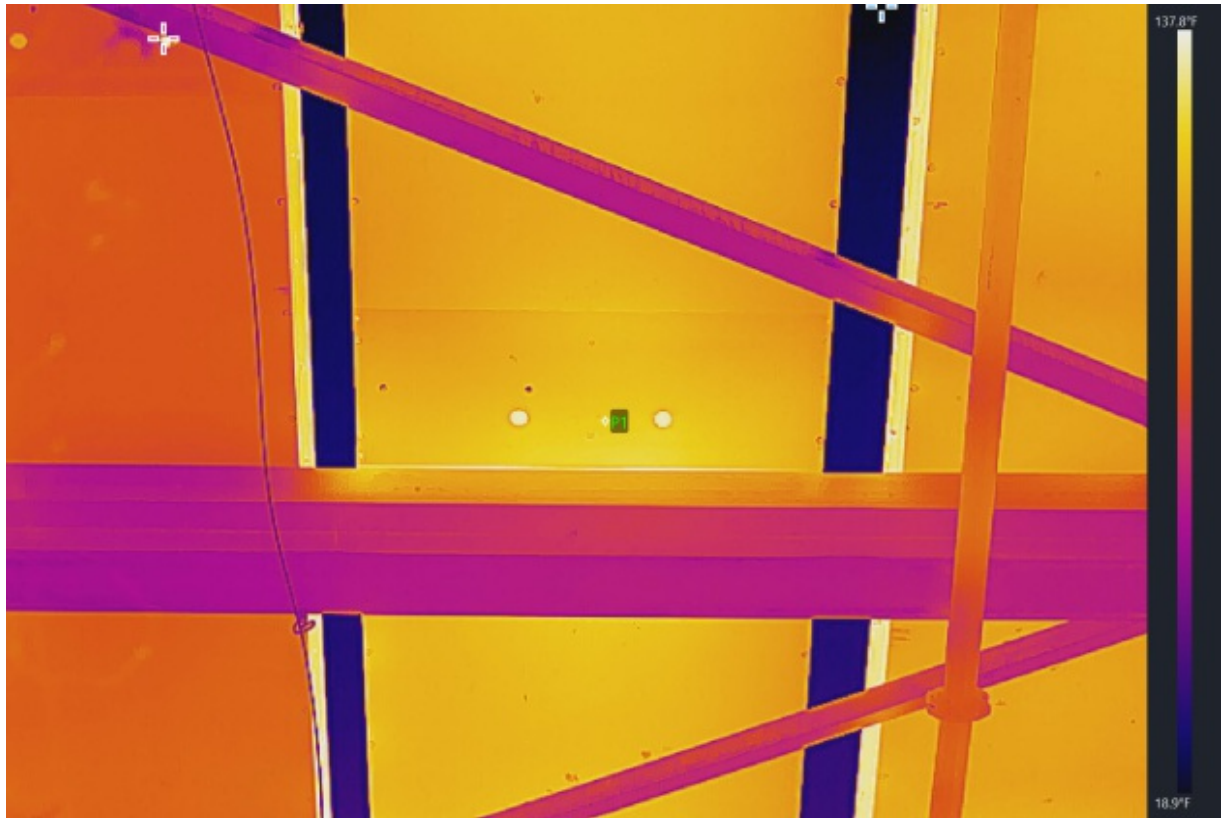

BUS DUCT HEATERS

Measurements		Image Parameters	
Image:Max. Temp.	137.8°F	Distance	1.5m
Image:Min. Temp.	18.9°F	Humidity	60%
P1	117.9°F	Emissivity	0.97
		Reflected Temp.	77.0°F
		Atmospheric Temp.	91.1°F

Measurement Parameters		Device Information	
P1:Emissivity	0.97	Device Model	SP60
P1:Reflected Temp.	77.0°F	Device Serial No.	L26310272
P1:Distance	1.5m	Captured At	2023-08-04 03:01:02

Text Annotation



BUS DUCT HEATERS

Measurements		Image Parameters	
Image:Max. Temp.	133.5°F	Distance	1.5m
Image:Min. Temp.	15.4°F	Humidity	60%
P1	117.1°F	Emissivity	0.97
P2	115.3°F	Reflected Temp.	77.0°F
		Atmospheric Temp.	91.0°F

Measurement Parameters		Device Information	
P1:Emissivity	0.97	Device Model	SP60
P1:Reflected Temp.	77.0°F	Device Serial No.	L26310272
P1:Distance	1.5m	Captured At	2023-08-04 03:00:56
P2:Emissivity	0.97		
P2:Reflected Temp.	77.0°F		
P2:Distance	1.5m		



BUS DUCT HEATERS

Measurements		Image Parameters	
Image:Max. Temp.	136.4°F	Distance	1.5m
Image:Min. Temp.	-0.4°F	Humidity	60%
P1	119.1°F	Emissivity	0.97
P2	116.8°F	Reflected Temp.	77.0°F
		Atmospheric Temp.	90.6°F

Measurement Parameters		Device Information	
P1:Emissivity	0.97	Device Model	SP60
P1:Reflected Temp.	77.0°F	Device Serial No.	L26310272
P1:Distance	1.5m	Captured At	2023-08-04 02:59:59
P2:Emissivity	0.97		
P2:Reflected Temp.	77.0°F		
P2:Distance	1.5m		

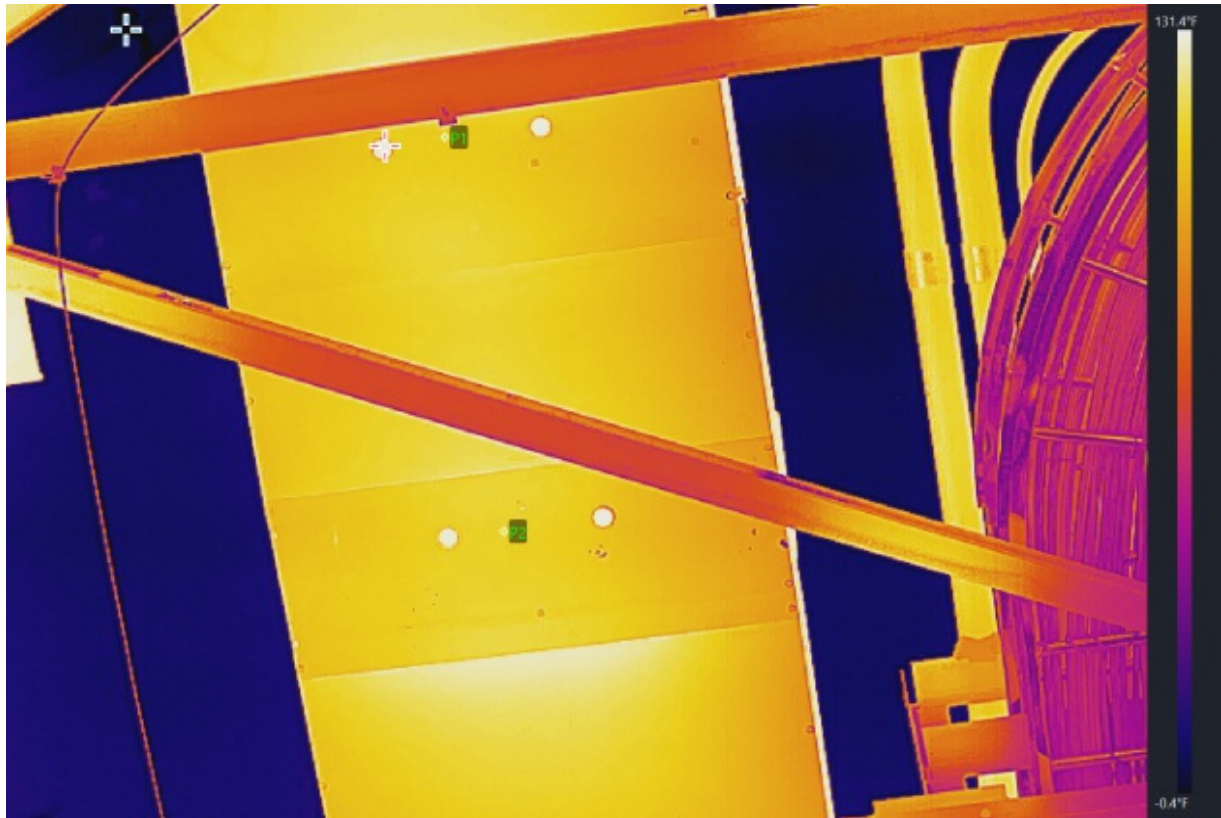

BUS DUCT HEATERS

Measurements		Image Parameters	
Image:Max. Temp.	131.4°F	Distance	1.5m
Image:Min. Temp.	-0.4°F	Humidity	60%
P1	118.8°F	Emissivity	0.97
P2	119.3°F	Reflected Temp.	77.0°F
		Atmospheric Temp.	90.6°F

Measurement Parameters		Device Information	
P1:Emissivity	0.97	Device Model	SP60
P1:Reflected Temp.	77.0°F	Device Serial No.	L26310272
P1:Distance	1.5m	Captured At	2023-08-04 02:59:46
P2:Emissivity	0.97		
P2:Reflected Temp.	77.0°F		
P2:Distance	1.5m		



BUS DUCT HEATERS

Measurements		Image Parameters	
Image:Max. Temp.	133.2°F	Distance	1.5m
Image:Min. Temp.	23.7°F	Humidity	60%
P1	118.6°F	Emissivity	0.97
P2	118.8°F	Reflected Temp.	77.0°F
P3	118.8°F	Atmospheric Temp.	90.5°F

Measurement Parameters		Device Information	
P1:Emissivity	0.97	Device Model	SP60
P1:Reflected Temp.	77.0°F	Device Serial No.	L26310272
P1:Distance	1.5m	Captured At	2023-08-04 02:59:20
P2:Emissivity	0.97		
P2:Reflected Temp.	77.0°F		
P2:Distance	1.5m		
P3:Emissivity	0.97		

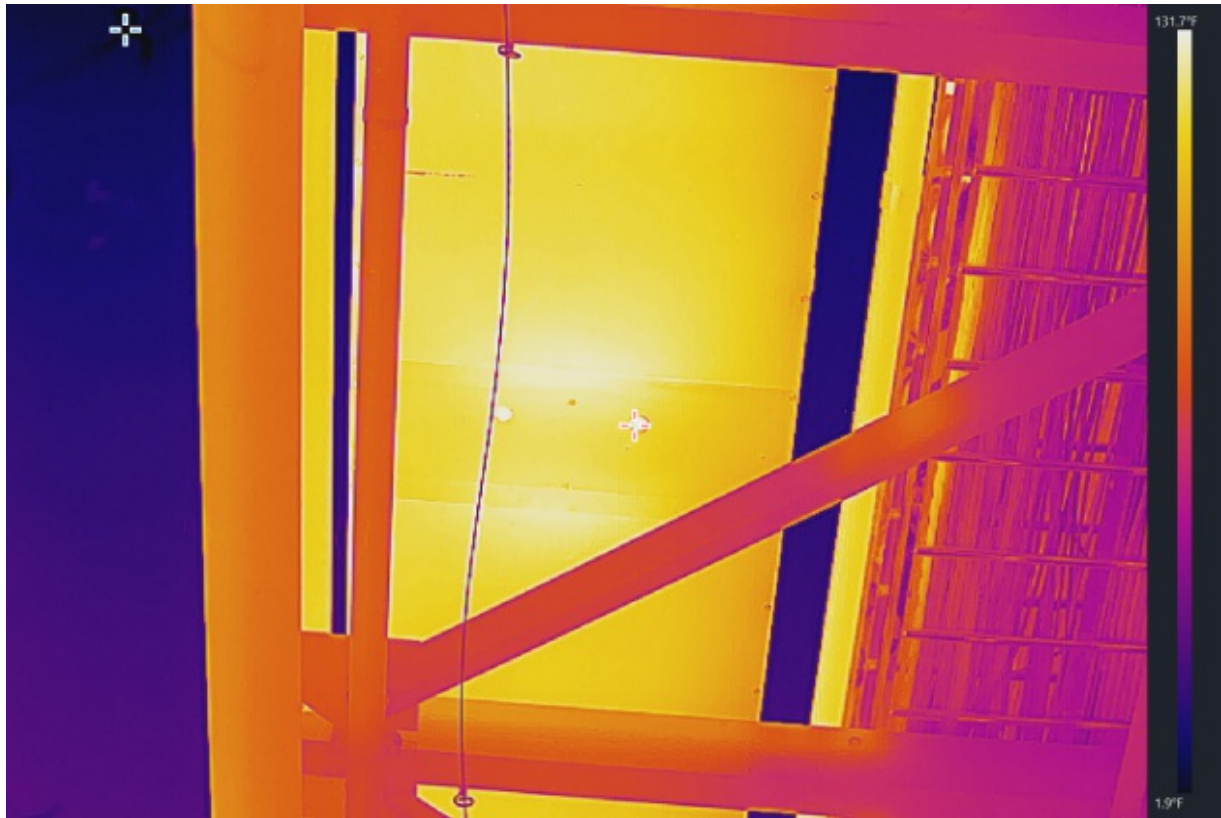

BUS DUCT HEATERS

Measurements		Image Parameters	
Image:Max. Temp.	131.7°F	Distance	1.5m
Image:Min. Temp.	1.9°F	Humidity	60%
		Emissivity	0.97
		Reflected Temp.	77.0°F
		Atmospheric Temp.	90.5°F
Measurement Parameters		Device Information	
		Device Model	SP60
		Device Serial No.	L26310272
		Captured At	2023-08-04 02:59:05
Text Annotation			

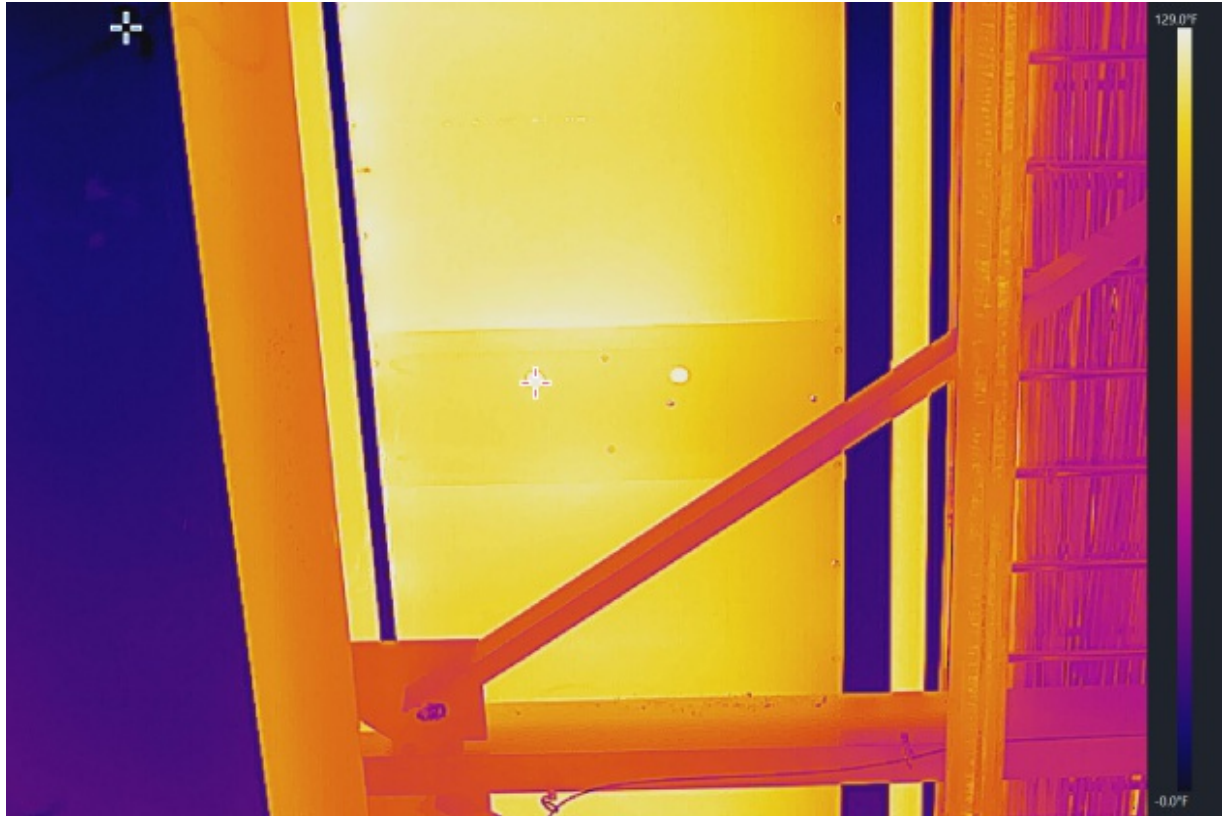

BUS DUCT HEATERS

Measurements		Image Parameters	
Image:Max. Temp.	129.0°F	Distance	1.5m
Image:Min. Temp.	-0.0°F	Humidity	60%
		Emissivity	0.97
		Reflected Temp.	77.0°F
		Atmospheric Temp.	90.6°F

Measurement Parameters	Device Information	
	Device Model	SP60
	Device Serial No.	L26310272
	Captured At	2023-08-04 02:58:55

Text Annotation

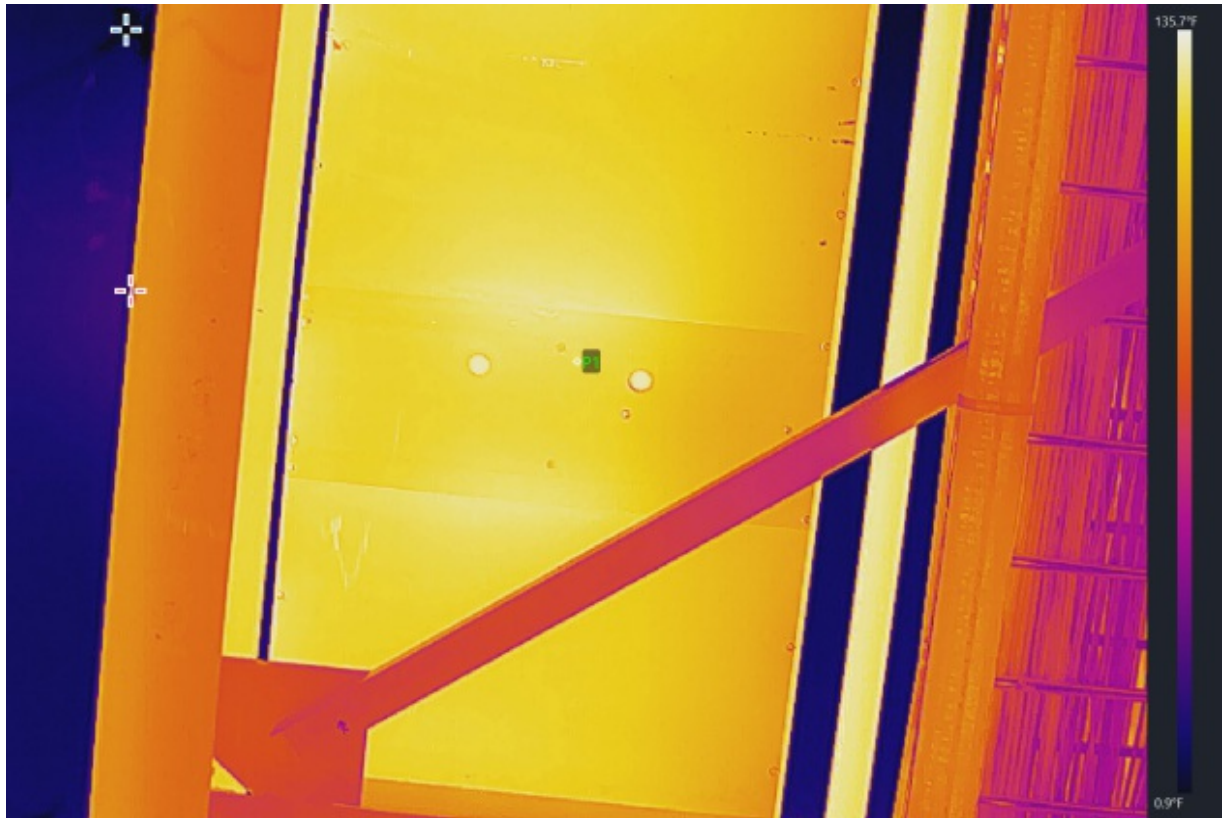

BUS DUCT HEATERS

Measurements		Image Parameters	
Image:Max. Temp.	135.7°F	Distance	1.5m
Image:Min. Temp.	0.9°F	Humidity	60%
P1	118.6°F	Emissivity	0.97
		Reflected Temp.	77.0°F
		Atmospheric Temp.	90.6°F

Measurement Parameters		Device Information	
P1:Emissivity	0.97	Device Model	SP60
P1:Reflected Temp.	77.0°F	Device Serial No.	L26310272
P1:Distance	1.5m	Captured At	2023-08-04 02:58:46

Text Annotation



BUS DUCT HEATERS

Measurements		Image Parameters	
Image:Max. Temp.	124.9°F	Distance	1.5m
Image:Min. Temp.	15.6°F	Humidity	60%
P1	113.5°F	Emissivity	0.97
		Reflected Temp.	77.0°F
		Atmospheric Temp.	90.7°F

Measurement Parameters		Device Information	
P1:Emissivity	0.97	Device Model	SP60
P1:Reflected Temp.	77.0°F	Device Serial No.	L26310272
P1:Distance	1.5m	Captured At	2023-08-04 02:58:36

Text Annotation



BUS DUCT HEATERS

Measurements		Image Parameters	
Image:Max. Temp.	110.8°F	Distance	1.5m
Image:Min. Temp.	30.4°F	Humidity	60%
P1	109.2°F	Emissivity	0.97
P2	106.7°F	Reflected Temp.	77.0°F
		Atmospheric Temp.	91.6°F

Measurement Parameters		Device Information	
P1:Emissivity	0.97	Device Model	SP60
P1:Reflected Temp.	77.0°F	Device Serial No.	L26310272
P1:Distance	1.5m	Captured At	2023-08-04 02:56:22
P2:Emissivity	0.97		
P2:Reflected Temp.	77.0°F		
P2:Distance	1.5m		

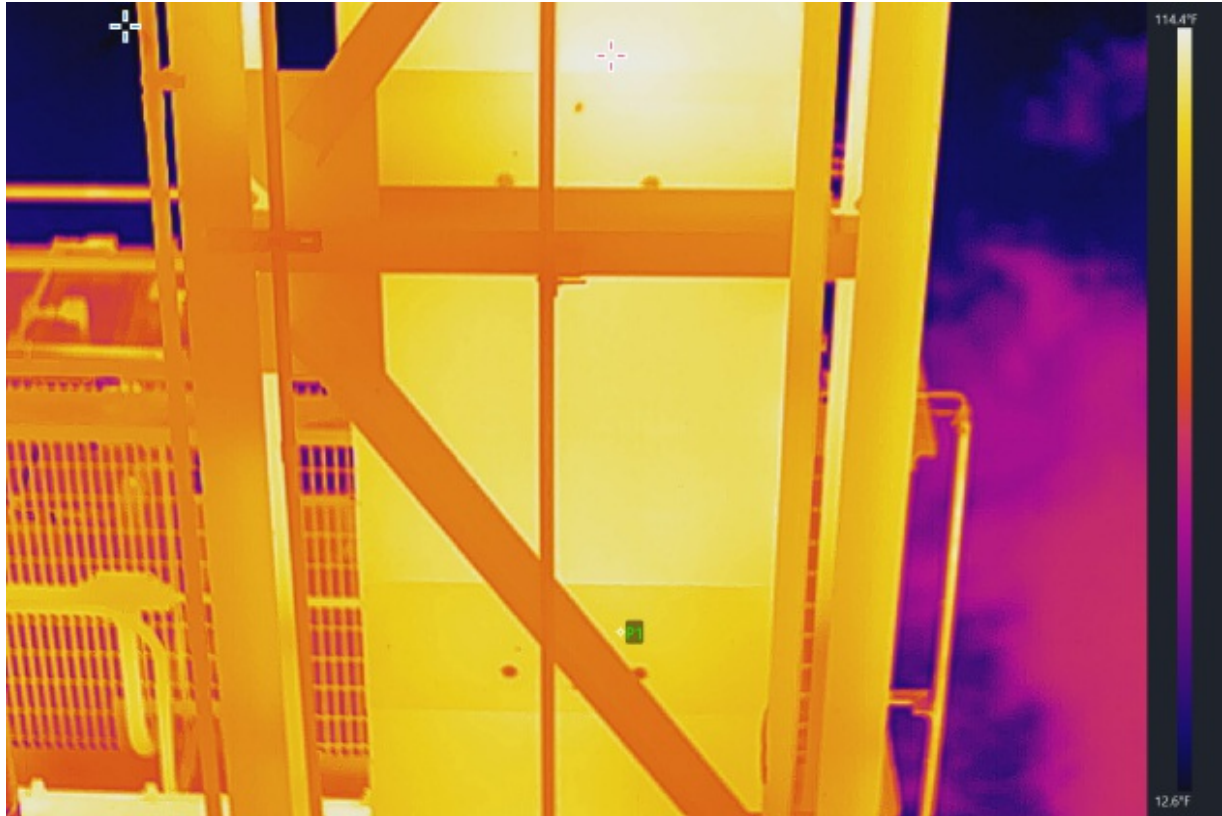

BUS DUCT HEATERS

Measurements		Image Parameters	
Image:Max. Temp.	114.4°F	Distance	1.5m
Image:Min. Temp.	12.6°F	Humidity	60%
P1	108.1°F	Emissivity	0.97
		Reflected Temp.	77.0°F
		Atmospheric Temp.	91.3°F

Measurement Parameters		Device Information	
P1:Emissivity	0.97	Device Model	SP60
P1:Reflected Temp.	77.0°F	Device Serial No.	L26310272
P1:Distance	1.5m	Captured At	2023-08-04 02:56:00

Text Annotation

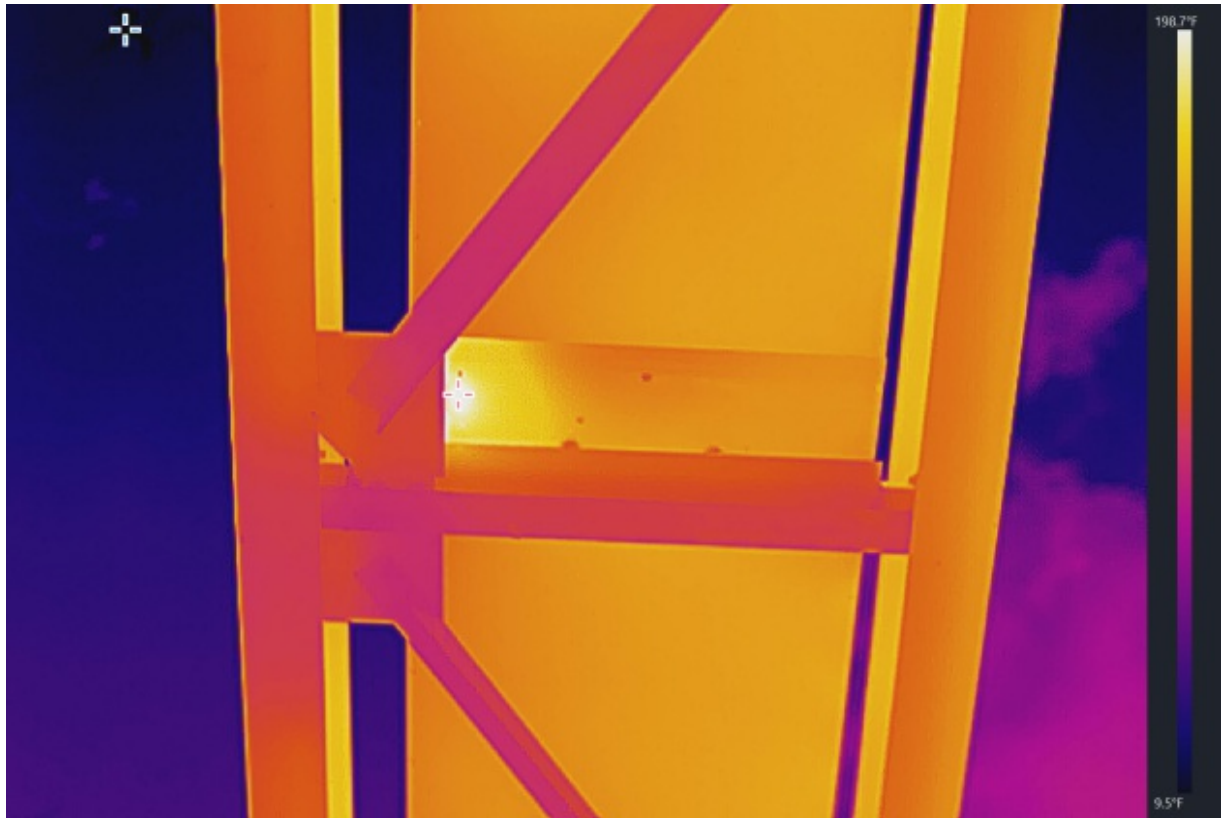

BUS DUCT HEATERS

Measurements		Image Parameters	
Image:Max. Temp.	198.7°F	Distance	1.5m
Image:Min. Temp.	9.5°F	Humidity	60%
		Emissivity	0.97
		Reflected Temp.	77.0°F
		Atmospheric Temp.	91.1°F
Measurement Parameters		Device Information	
		Device Model	SP60
		Device Serial No.	L26310272
		Captured At	2023-08-04 02:55:35
Text Annotation			

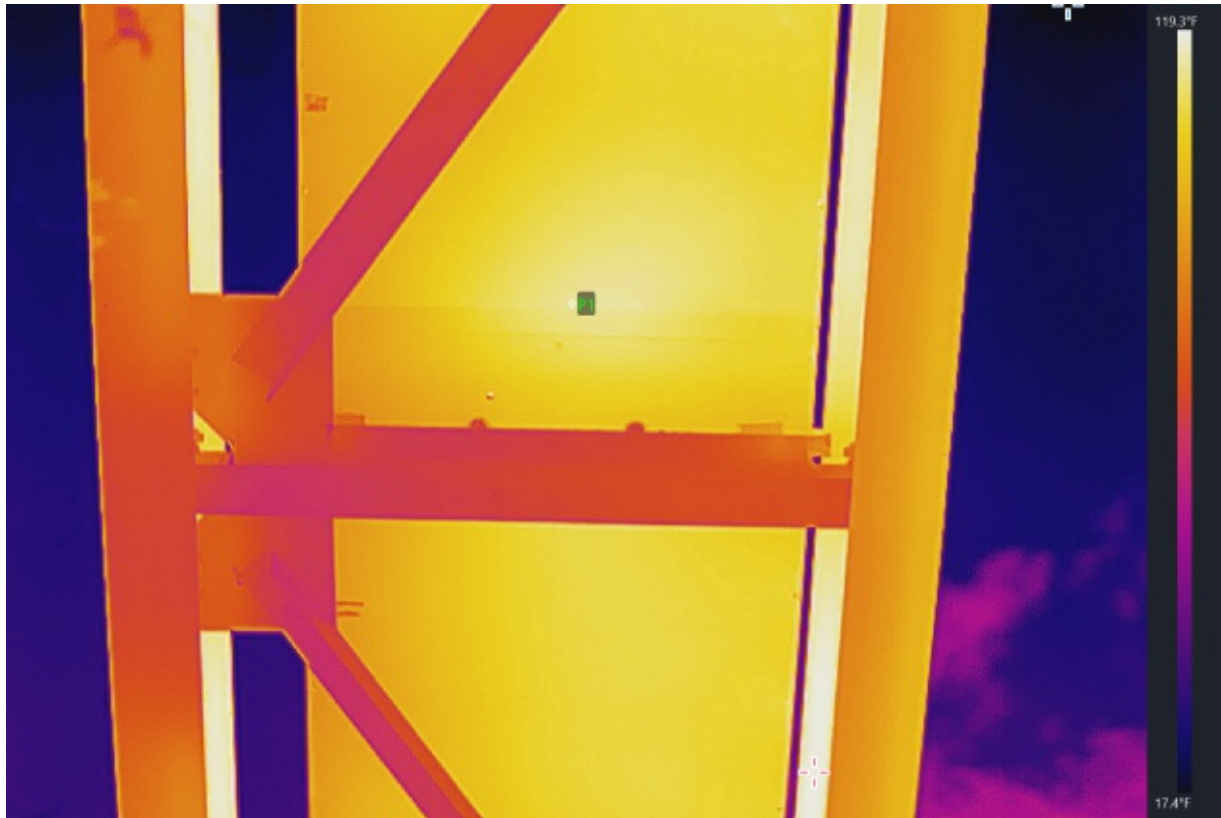

BUS DUCT HEATERS

Measurements		Image Parameters	
Image:Max. Temp.	119.3°F	Distance	1.5m
Image:Min. Temp.	17.4°F	Humidity	60%
P1	117.0°F	Emissivity	0.97
		Reflected Temp.	77.0°F
		Atmospheric Temp.	91.1°F

Measurement Parameters		Device Information	
P1:Emissivity	0.97	Device Model	SP60
P1:Reflected Temp.	77.0°F	Device Serial No.	L26310272
P1:Distance	1.5m	Captured At	2023-08-04 02:55:25

Text Annotation

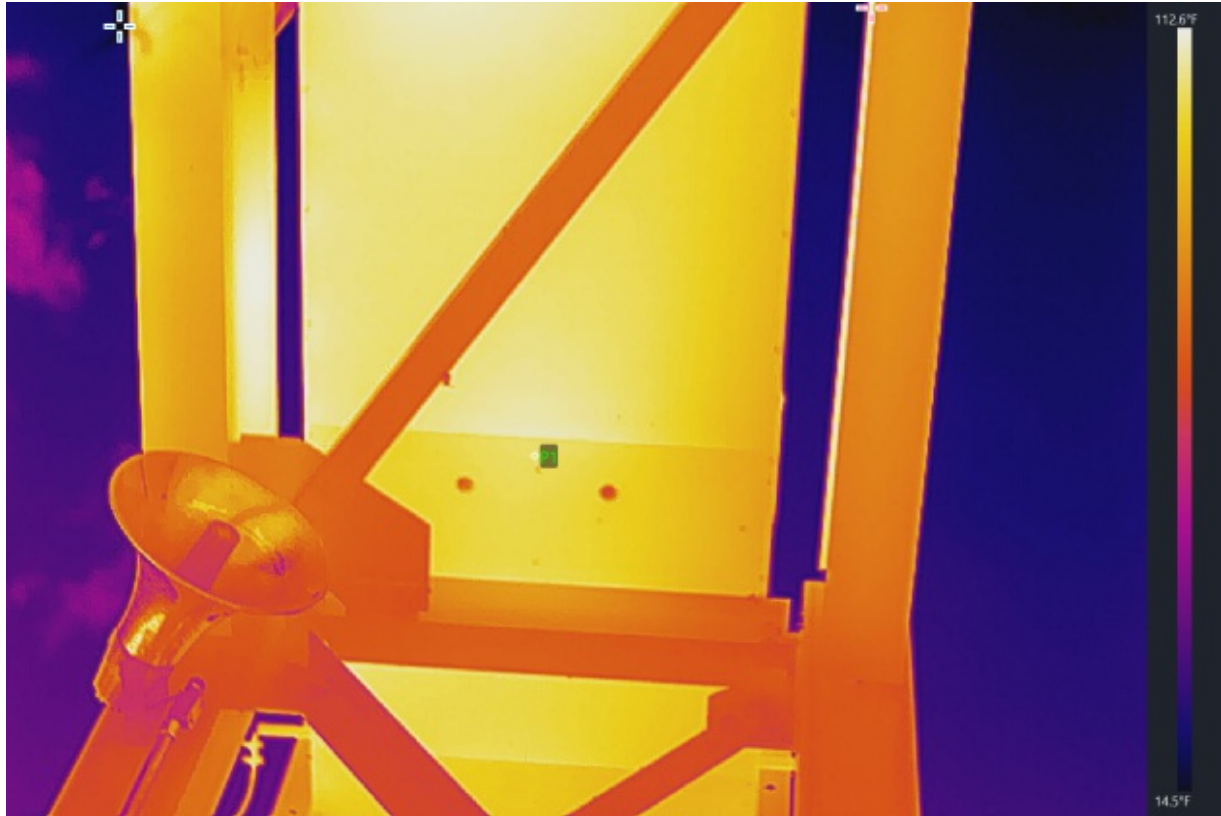

BUS DUCT HEATERS

Measurements		Image Parameters	
Image:Max. Temp.	112.6°F	Distance	1.5m
Image:Min. Temp.	14.5°F	Humidity	60%
P1	109.2°F	Emissivity	0.97
		Reflected Temp.	77.0°F
		Atmospheric Temp.	91.1°F

Measurement Parameters		Device Information	
P1:Emissivity	0.97	Device Model	SP60
P1:Reflected Temp.	77.0°F	Device Serial No.	L26310272
P1:Distance	1.5m	Captured At	2023-08-04 02:55:01

Text Annotation

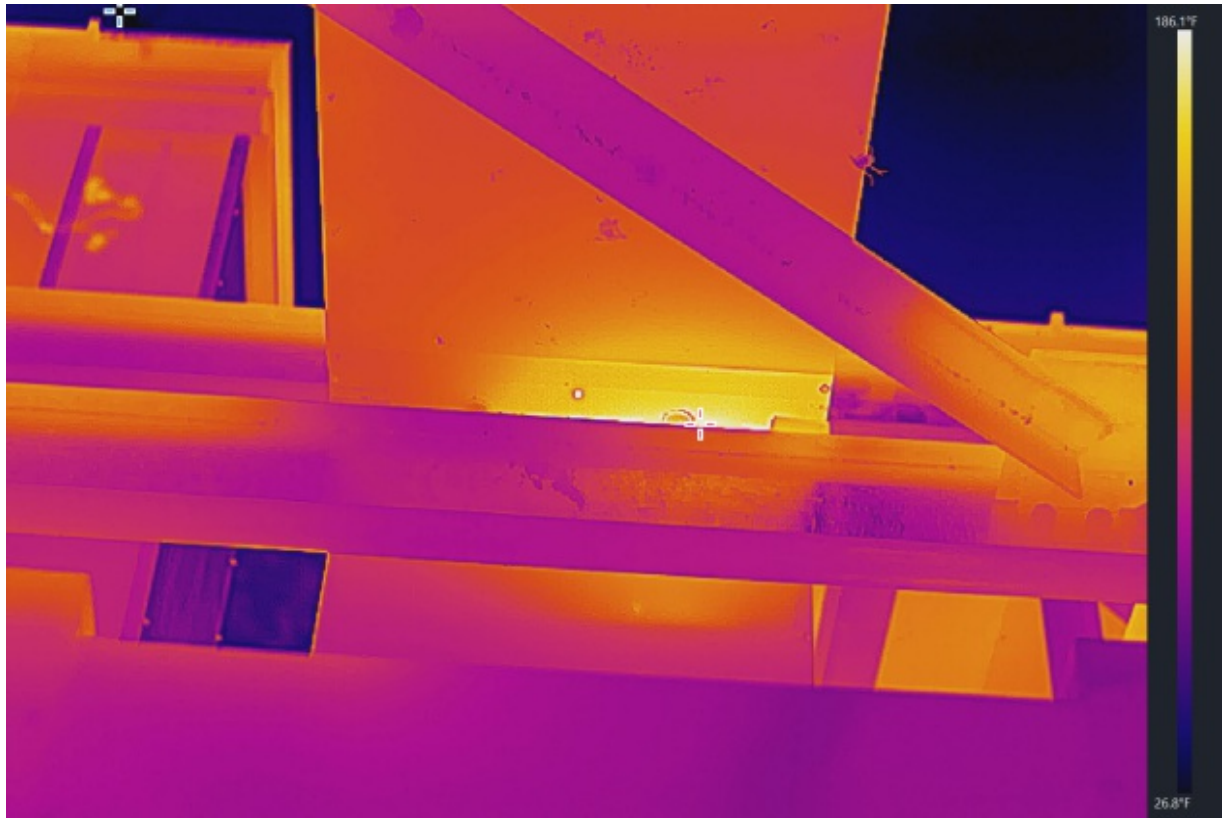

BUS DUCT HEATERS

Measurements		Image Parameters	
Image:Max. Temp.	186.1°F	Distance	1.5m
Image:Min. Temp.	26.8°F	Humidity	60%
		Emissivity	0.97
		Reflected Temp.	77.0°F
		Atmospheric Temp.	91.1°F

Measurement Parameters		Device Information	
		Device Model	SP60
		Device Serial No.	L26310272
		Captured At	2023-08-04 02:53:13

Text Annotation

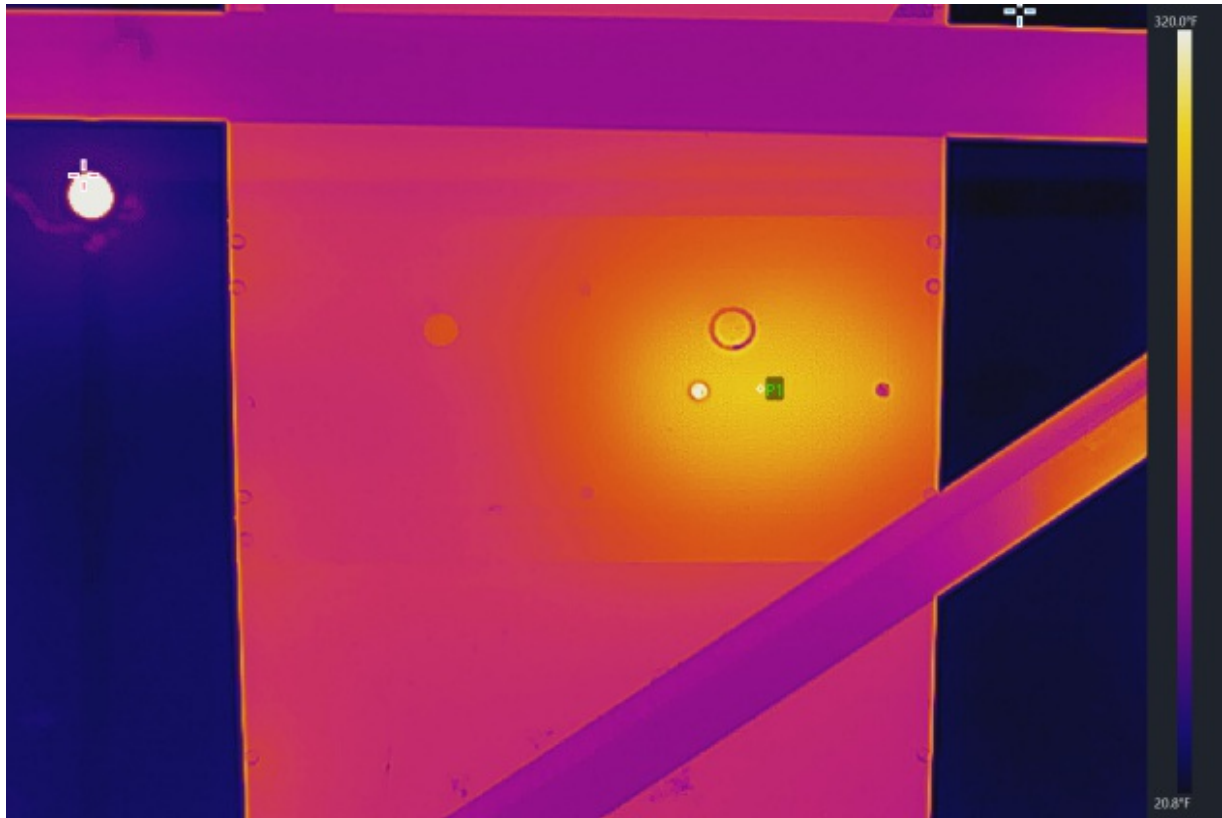

BUS DUCT HEATERS

Measurements		Image Parameters	
Image:Max. Temp.	>320.0°F	Distance	1.5m
Image:Min. Temp.	20.8°F	Humidity	60%
P1	136.6°F	Emissivity	0.97
		Reflected Temp.	77.0°F
		Atmospheric Temp.	91.1°F

Measurement Parameters		Device Information	
P1:Emissivity	0.97	Device Model	SP60
P1:Reflected Temp.	77.0°F	Device Serial No.	L26310272
P1:Distance	1.5m	Captured At	2023-08-04 02:53:04

Text Annotation

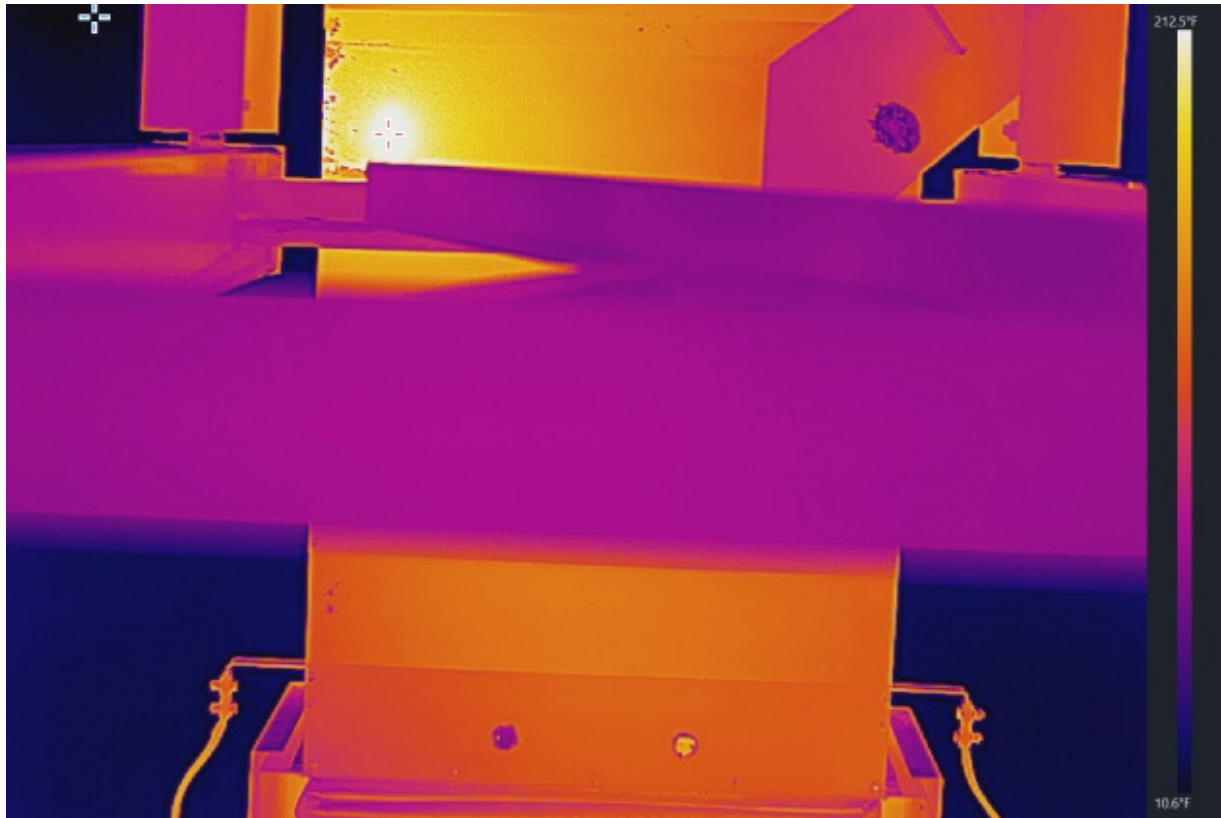

BUS DUCT HEATERS

Measurements		Image Parameters	
Image:Max. Temp.	212.5°F	Distance	1.5m
Image:Min. Temp.	10.6°F	Humidity	60%
		Emissivity	0.97
		Reflected Temp.	77.0°F
		Atmospheric Temp.	91.8°F
Measurement Parameters		Device Information	
		Device Model	SP60
		Device Serial No.	L26310272
		Captured At	2023-08-04 02:52:16
Text Annotation			

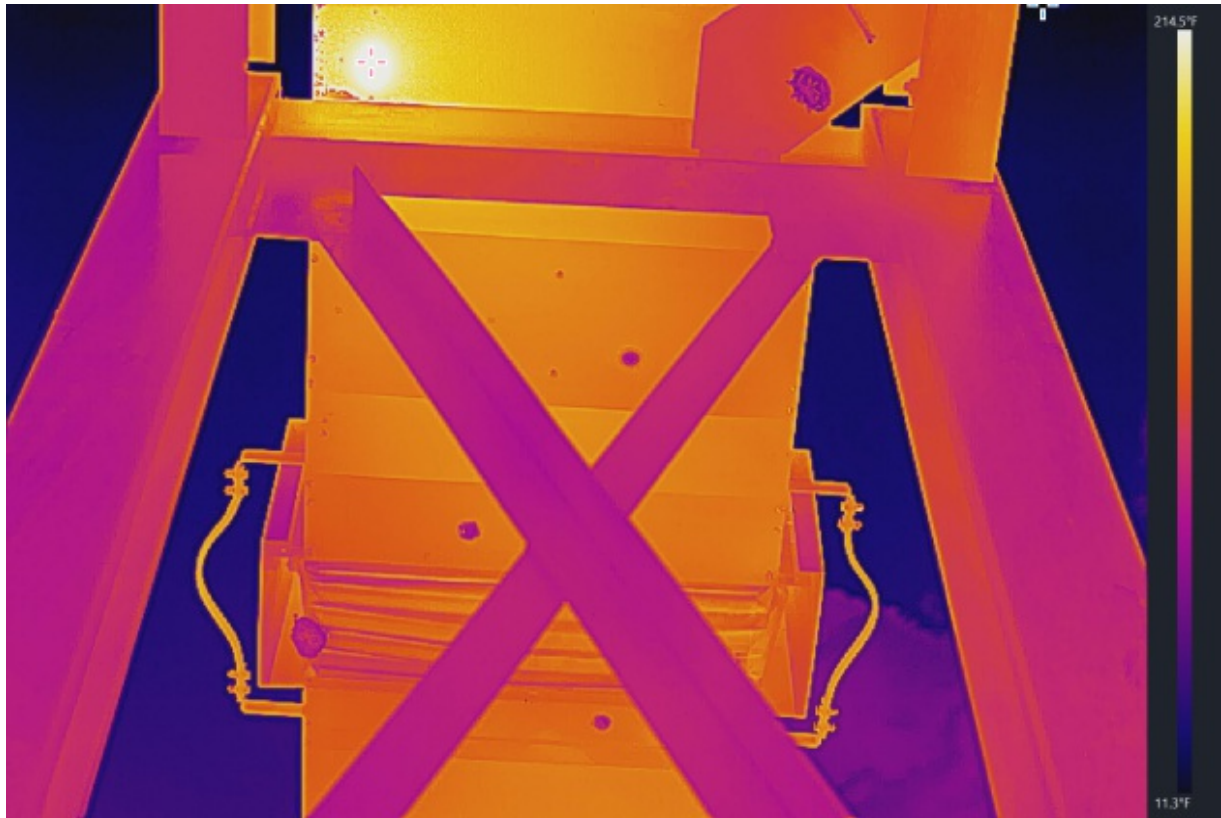

BUS DUCT HEATERS

Measurements		Image Parameters	
Image:Max. Temp.	214.5°F	Distance	1.5m
Image:Min. Temp.	11.3°F	Humidity	60%
		Emissivity	0.97
		Reflected Temp.	77.0°F
		Atmospheric Temp.	92.1°F

Measurement Parameters		Device Information	
		Device Model	SP60
		Device Serial No.	L26310272
		Captured At	2023-08-04 02:52:02

Text Annotation

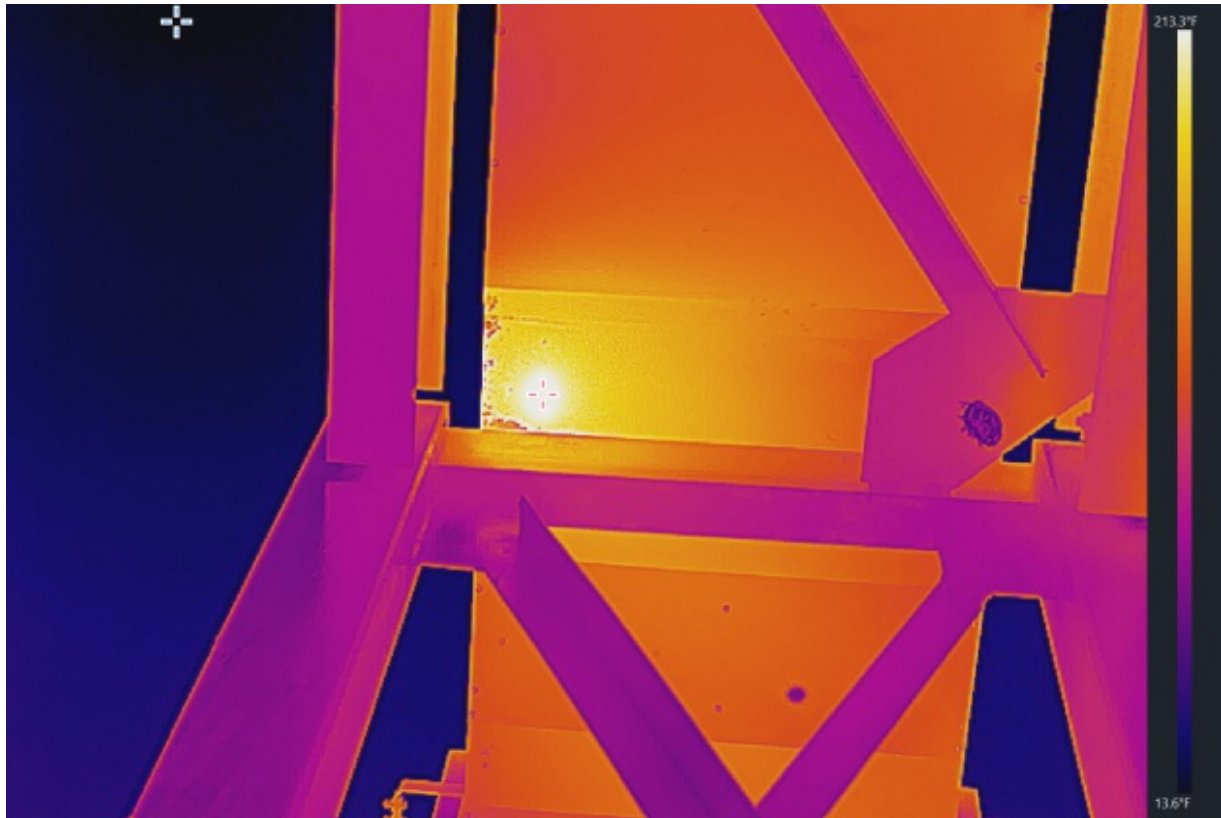

BUS DUCT HEATERS

Measurements		Image Parameters	
Image:Max. Temp.	213.3°F	Distance	1.5m
Image:Min. Temp.	13.6°F	Humidity	60%
		Emissivity	0.97
		Reflected Temp.	77.0°F
		Atmospheric Temp.	92.2°F

Measurement Parameters		Device Information	
		Device Model	SP60
		Device Serial No.	L26310272
		Captured At	2023-08-04 02:51:54

Text Annotation

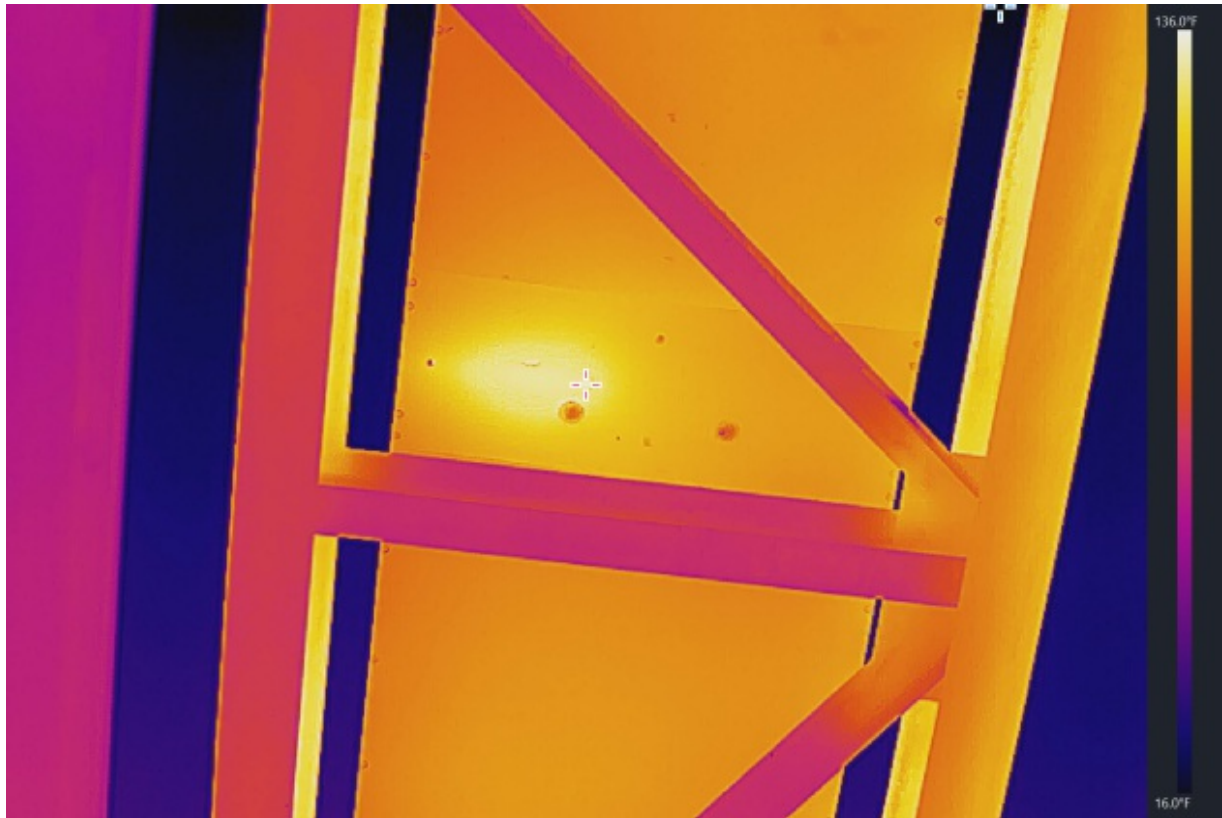

BUS DUCT HEATERS

Measurements		Image Parameters	
Image:Max. Temp.	136.0°F	Distance	1.5m
Image:Min. Temp.	16.0°F	Humidity	60%
		Emissivity	0.97
		Reflected Temp.	77.0°F
		Atmospheric Temp.	92.3°F

Measurement Parameters		Device Information	
		Device Model	SP60
		Device Serial No.	L26310272
		Captured At	2023-08-04 02:51:40

Text Annotation

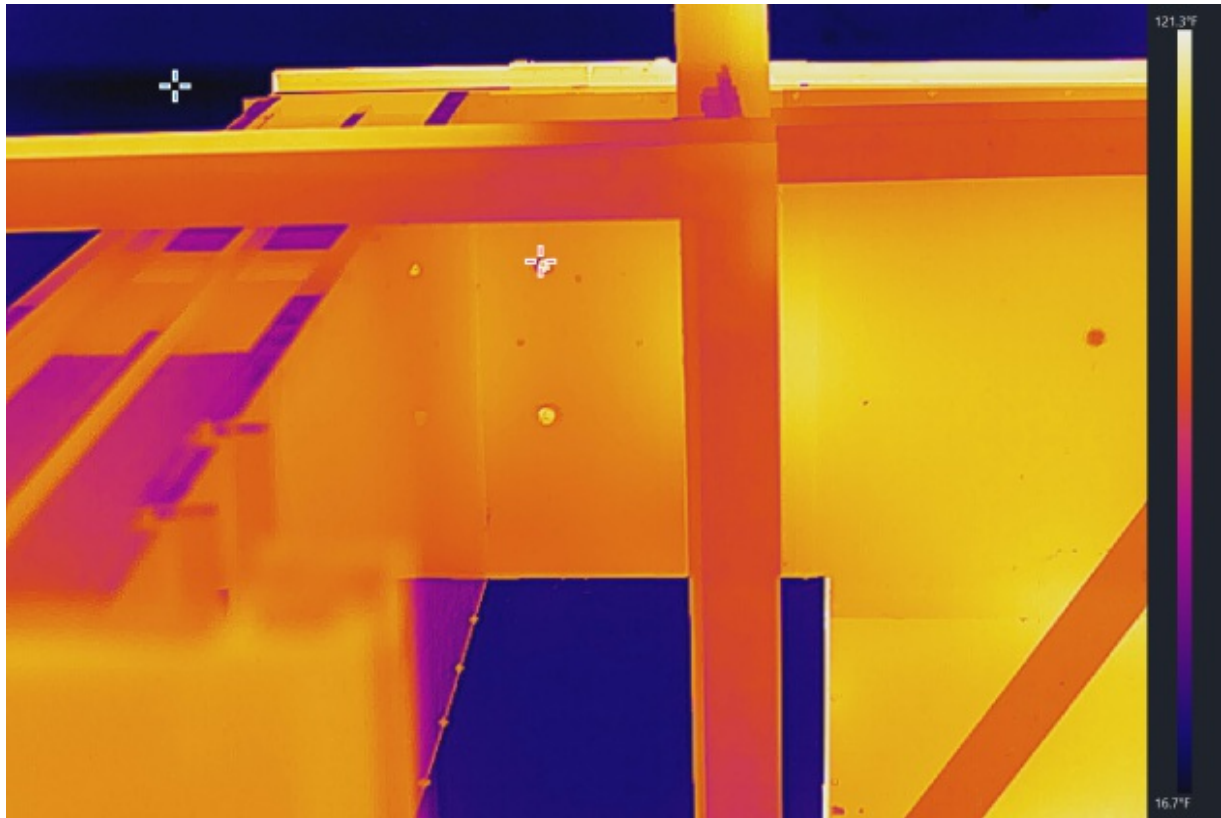

BUS DUCT HEATERS

Measurements		Image Parameters	
Image:Max. Temp.	121.3°F	Distance	1.5m
Image:Min. Temp.	16.7°F	Humidity	60%
		Emissivity	0.97
		Reflected Temp.	77.0°F
		Atmospheric Temp.	92.2°F
Measurement Parameters		Device Information	
		Device Model	SP60
		Device Serial No.	L26310272
		Captured At	2023-08-04 02:51:08
Text Annotation			

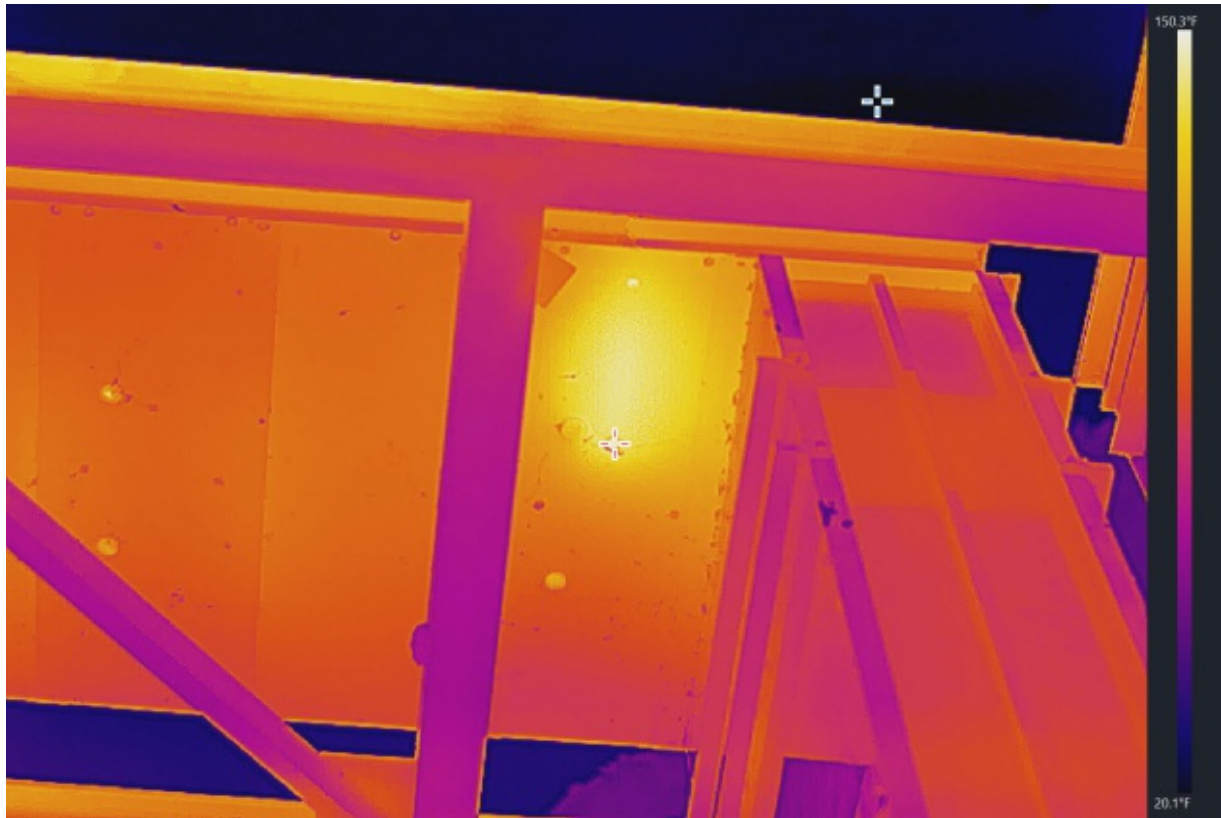

BUS DUCT HEATERS

Measurements		Image Parameters	
Image:Max. Temp.	150.3°F	Distance	1.5m
Image:Min. Temp.	20.1°F	Humidity	60%
		Emissivity	0.97
		Reflected Temp.	77.0°F
		Atmospheric Temp.	91.9°F
Measurement Parameters		Device Information	
		Device Model	SP60
		Device Serial No.	L26310272
		Captured At	2023-08-04 02:50:47
Text Annotation			

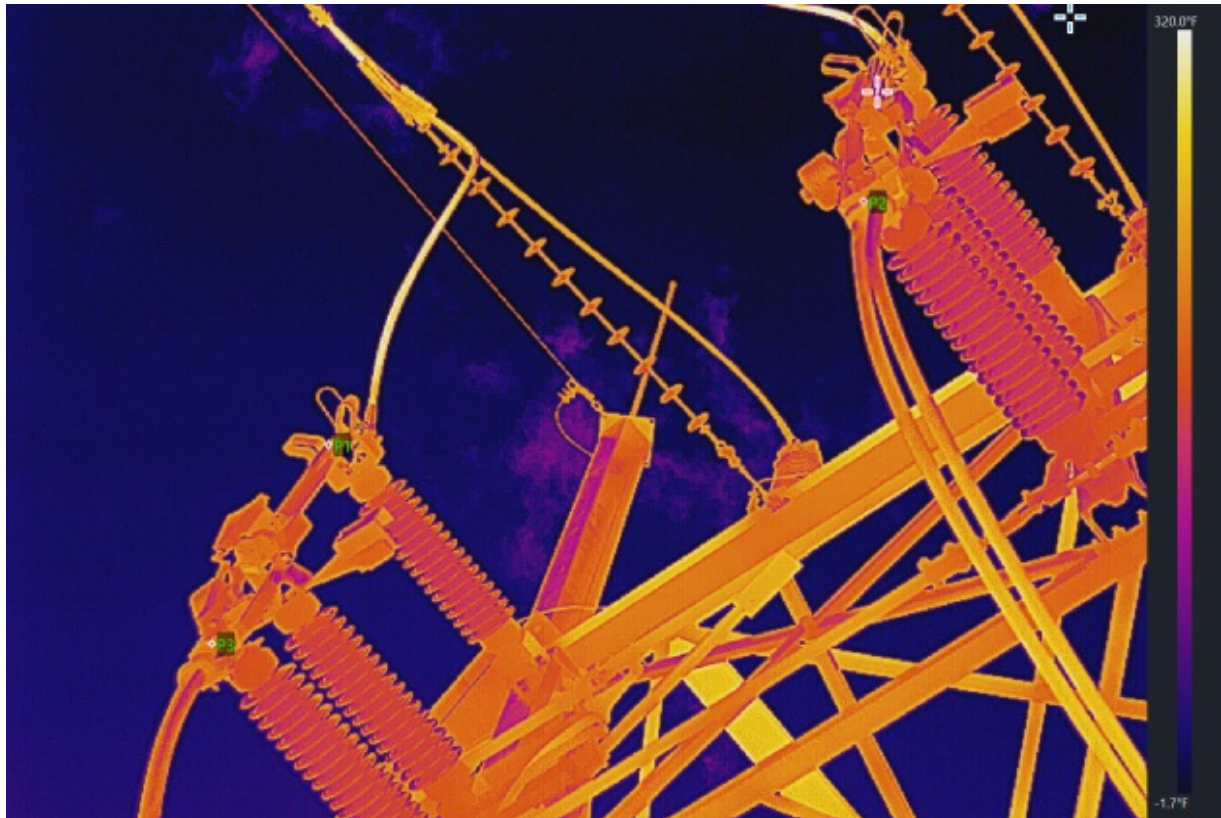

SWITCHYARD MAIN SWITCH

Measurements		Image Parameters	
Image:Max. Temp.	>320.0°F	Distance	1.5m
Image:Min. Temp.	-1.7°F	Humidity	60%
P1	83.8°F	Emissivity	0.97
P2	89.4°F	Reflected Temp.	77.0°F
P3	91.2°F	Atmospheric Temp.	90.2°F

Measurement Parameters		Device Information	
P1:Emissivity	0.97	Device Model	SP60
P1:Reflected Temp.	77.0°F	Device Serial No.	L26310272
P1:Distance	1.5m	Captured At	2023-08-04 02:48:43
P2:Emissivity	0.97		
P2:Reflected Temp.	77.0°F		
P2:Distance	1.5m		
P3:Emissivity	0.97		



SWITCHYARD MAIN SWITCH

Measurements		Image Parameters	
Image:Max. Temp.	110.3°F	Distance	1.5m
Image:Min. Temp.	4.1°F	Humidity	60%
P1	102.0°F	Emissivity	0.97
		Reflected Temp.	77.0°F
		Atmospheric Temp.	90.0°F

Measurement Parameters		Device Information	
P1:Emissivity	0.97	Device Model	SP60
P1:Reflected Temp.	77.0°F	Device Serial No.	L26310272
P1:Distance	1.5m	Captured At	2023-08-04 02:48:30

Text Annotation

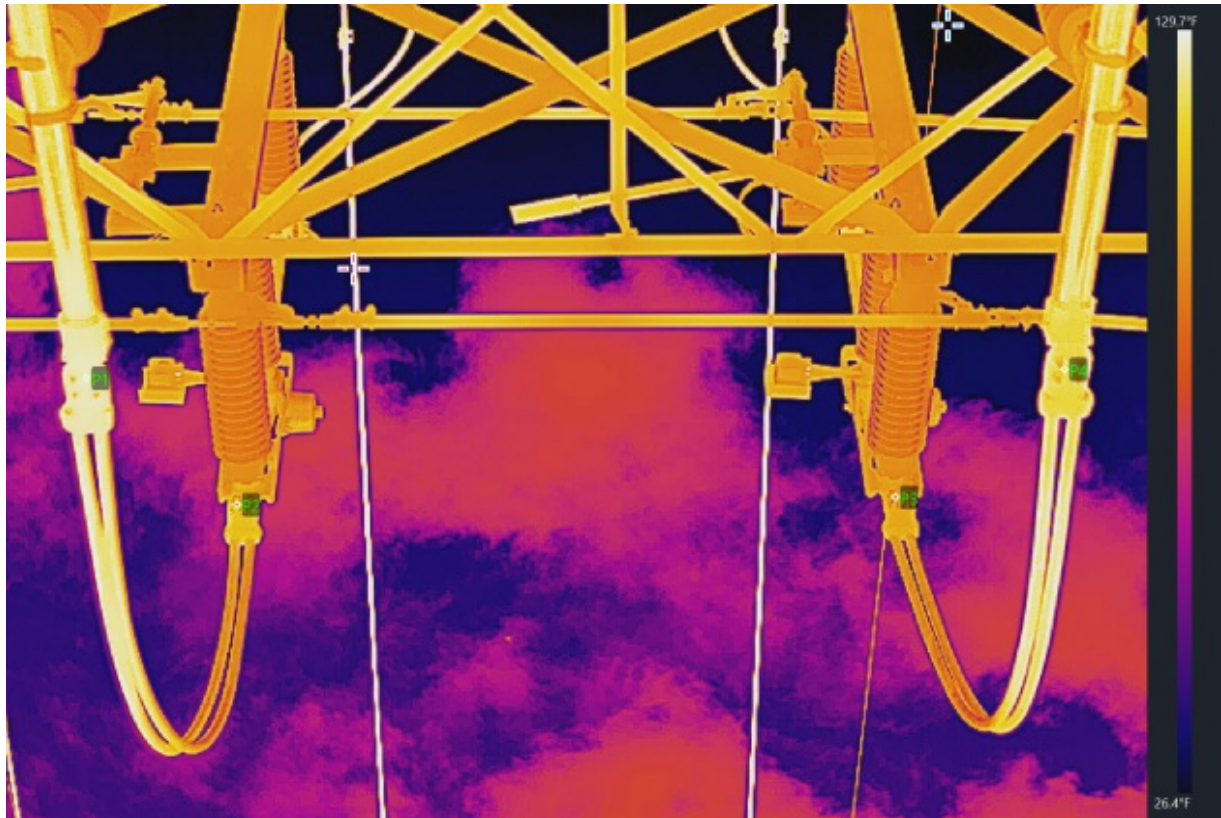

SWITCHYARD MAIN SWITCH

Measurements	
Image:Max. Temp.	129.7°F
Image:Min. Temp.	26.4°F
P1	116.2°F
P2	102.2°F
P3	97.2°F
P4	108.7°F

Image Parameters	
Distance	1.5m
Humidity	60%
Emissivity	0.97
Reflected Temp.	77.0°F
Atmospheric Temp.	89.2°F

Measurement Parameters	
P1:Emissivity	0.97
P1:Reflected Temp.	77.0°F
P1:Distance	1.5m
P2:Emissivity	0.97
P2:Reflected Temp.	77.0°F
P2:Distance	1.5m

Device Information	
Device Model	SP60
Device Serial No.	L26310272
Captured At	2023-08-04 02:47:36

P3:Emissivity	0.97
P3:Reflected Temp.	77.0°F
P3:Distance	1.5m
P4:Emissivity	0.97
P4:Reflected Temp.	77.0°F
P4:Distance	1.5m

Text Annotation

Remarks

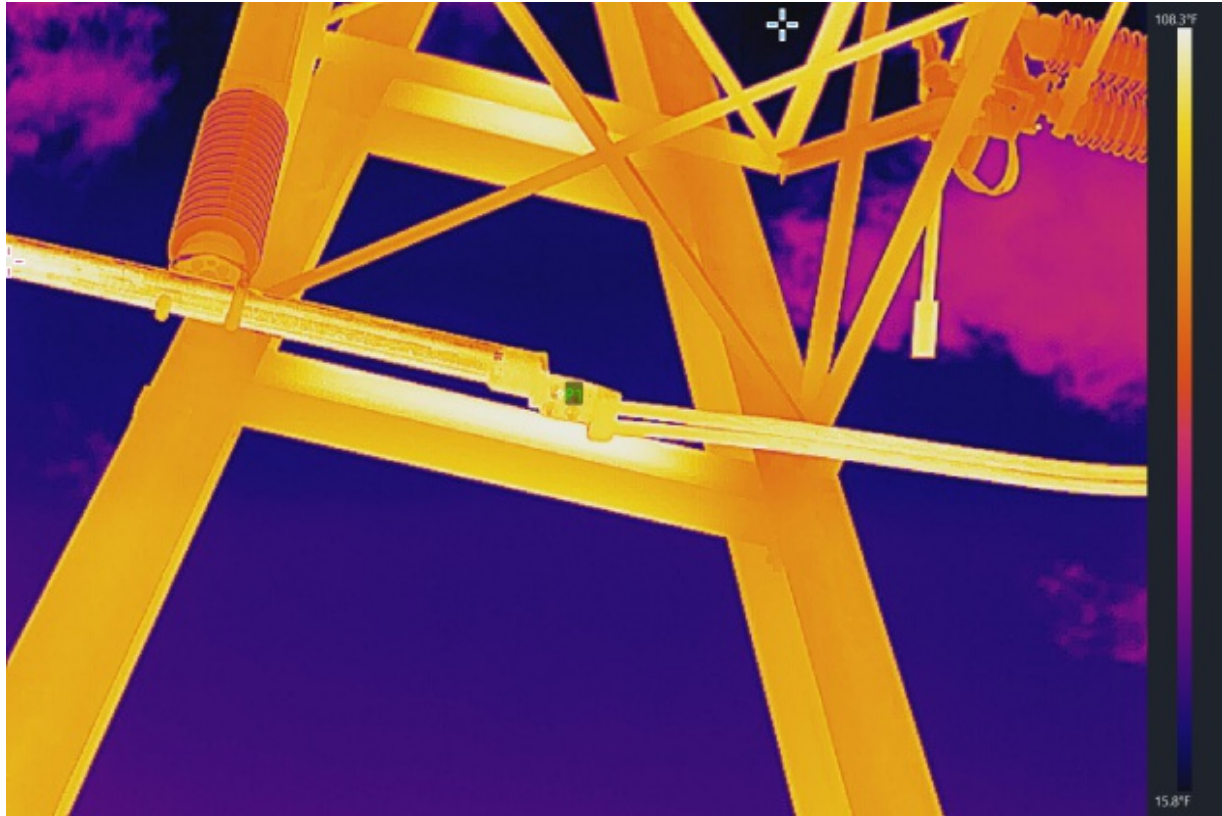

SWITCHYARD MAIN SWITCH

Measurements		Image Parameters	
Image:Max. Temp.	108.3°F	Distance	1.5m
Image:Min. Temp.	15.8°F	Humidity	60%
P1	101.1°F	Emissivity	0.97
		Reflected Temp.	77.0°F
		Atmospheric Temp.	89.2°F

Measurement Parameters		Device Information	
P1:Emissivity	0.97	Device Model	SP60
P1:Reflected Temp.	77.0°F	Device Serial No.	L26310272
P1:Distance	1.5m	Captured At	2023-08-04 02:46:45

Text Annotation



T2-GSU - HIGH SIDE BUSHINGS

Measurements		Image Parameters	
Image:Max. Temp.	147.4°F	Distance	1.5m
Image:Min. Temp.	39.6°F	Humidity	60%
P1	96.6°F	Emissivity	0.97
P2	96.1°F	Reflected Temp.	77.0°F
		Atmospheric Temp.	89.5°F

Measurement Parameters		Device Information	
P1:Emissivity	0.97	Device Model	SP60
P1:Reflected Temp.	77.0°F	Device Serial No.	L26310272
P1:Distance	1.5m	Captured At	2023-08-04 02:45:55
P2:Emissivity	0.97		
P2:Reflected Temp.	77.0°F		
P2:Distance	1.5m		



T2-GSU - HIGH SIDE BUSHINGS

Measurements		Image Parameters	
Image:Max. Temp.	126.0°F	Distance	1.5m
Image:Min. Temp.	40.1°F	Humidity	60%
P1	112.5°F	Emissivity	0.97
		Reflected Temp.	77.0°F
		Atmospheric Temp.	89.5°F

Measurement Parameters		Device Information	
P1:Emissivity	0.97	Device Model	SP60
P1:Reflected Temp.	77.0°F	Device Serial No.	L26310272
P1:Distance	1.5m	Captured At	2023-08-04 02:45:07

Text Annotation

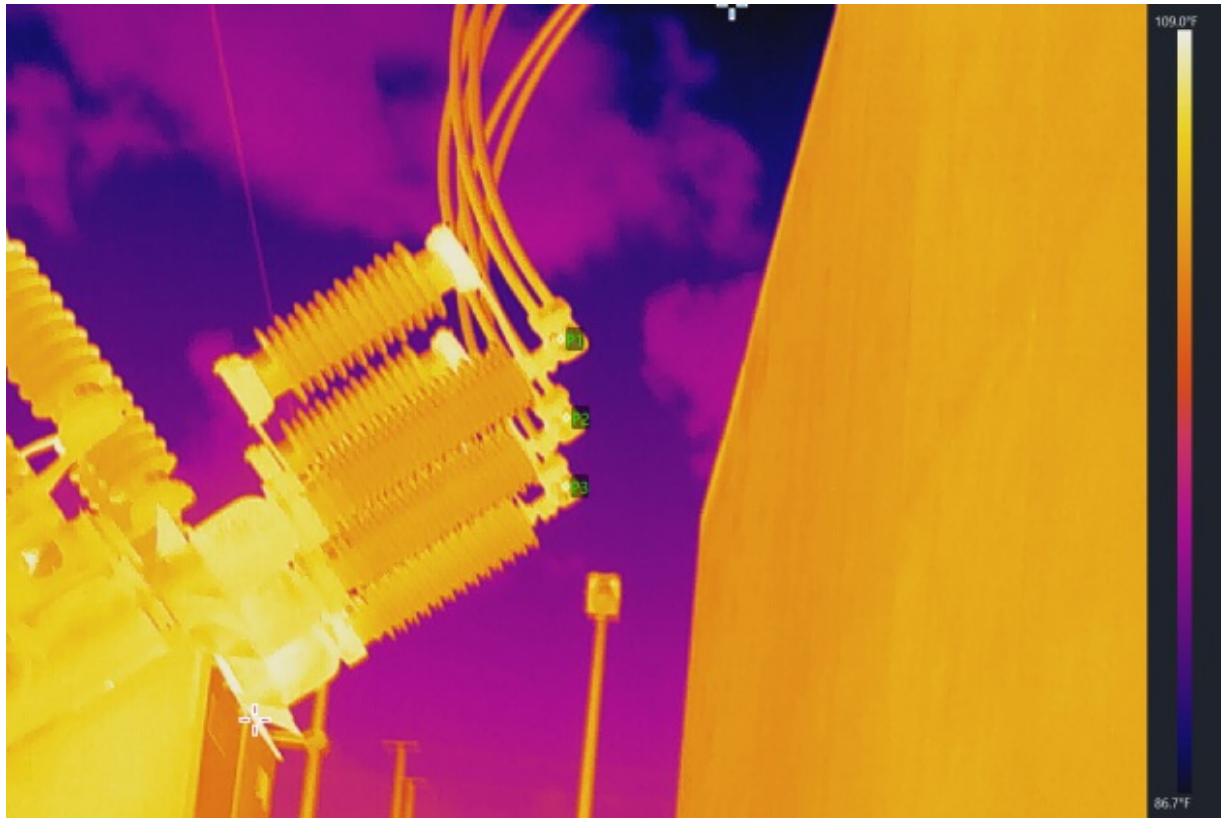

52-L2 - SF6 BREAKER

Measurements		Image Parameters	
Image:Max. Temp.	109.0°F	Distance	1.5m
Image:Min. Temp.	86.7°F	Humidity	60%
P1	104.9°F	Emissivity	0.97
P2	104.7°F	Reflected Temp.	77.0°F
P3	104.7°F	Atmospheric Temp.	88.5°F

Measurement Parameters		Device Information	
P1:Emissivity	0.97	Device Model	SP60
P1:Reflected Temp.	77.0°F	Device Serial No.	L26310272
P1:Distance	1.5m	Captured At	2023-08-04 02:44:07
P2:Emissivity	0.97		
P2:Reflected Temp.	77.0°F		
P2:Distance	1.5m		
P3:Emissivity	0.97		

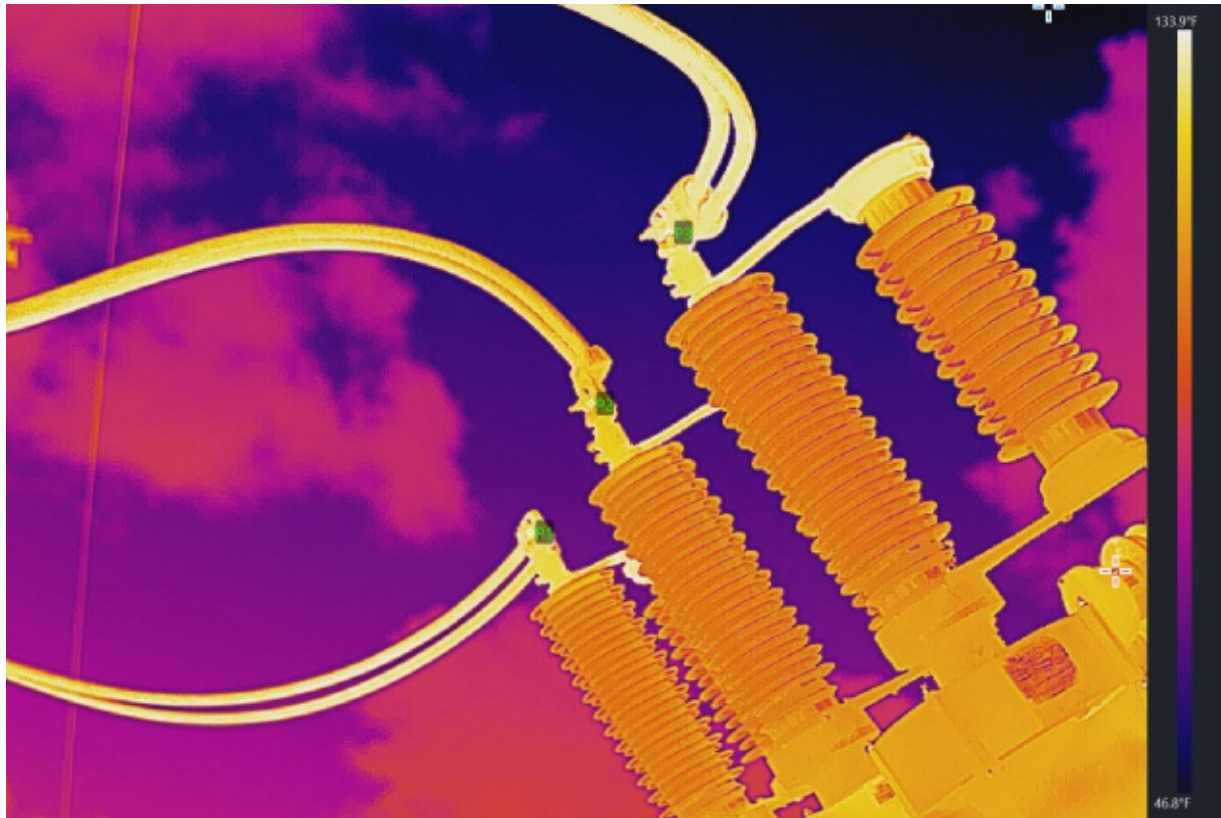

52-L2 - SF6 BREAKER

Measurements		Image Parameters	
Image:Max. Temp.	133.9°F	Distance	1.5m
Image:Min. Temp.	46.8°F	Humidity	60%
P1	113.5°F	Emissivity	0.97
P2	109.6°F	Reflected Temp.	77.0°F
P3	109.0°F	Atmospheric Temp.	86.5°F

Measurement Parameters		Device Information	
P1:Emissivity	0.97	Device Model	SP60
P1:Reflected Temp.	77.0°F	Device Serial No.	L26310272
P1:Distance	1.5m	Captured At	2023-08-04 02:42:45
P2:Emissivity	0.97		
P2:Reflected Temp.	77.0°F		
P2:Distance	1.5m		
P3:Emissivity	0.97		



T2 - MAIN AIR SWITCH

Measurements		Image Parameters	
Image:Max. Temp.	124.3°F	Distance	1.5m
Image:Min. Temp.	53.4°F	Humidity	60%
P1	112.5°F	Emissivity	0.97
P2	110.7°F	Reflected Temp.	77.0°F
P3	114.1°F	Atmospheric Temp.	86.2°F
P4	109.4°F		
P5	113.5°F		

Measurement Parameters		Device Information	
P1:Emissivity	0.97	Device Model	SP60
P1:Reflected Temp.	77.0°F	Device Serial No.	L26310272
P1:Distance	1.5m	Captured At	2023-08-04 02:42:17
P2:Emissivity	0.97		
P2:Reflected Temp.	77.0°F		

P2:Distance	1.5m
P3:Emissivity	0.97
P3:Reflected Temp.	77.0°F
P3:Distance	1.5m
P4:Emissivity	0.97
P4:Reflected Temp.	77.0°F
P4:Distance	1.5m
P5:Emissivity	0.97
P5:Reflected Temp.	77.0°F
P5:Distance	1.5m

Text Annotation

Remarks

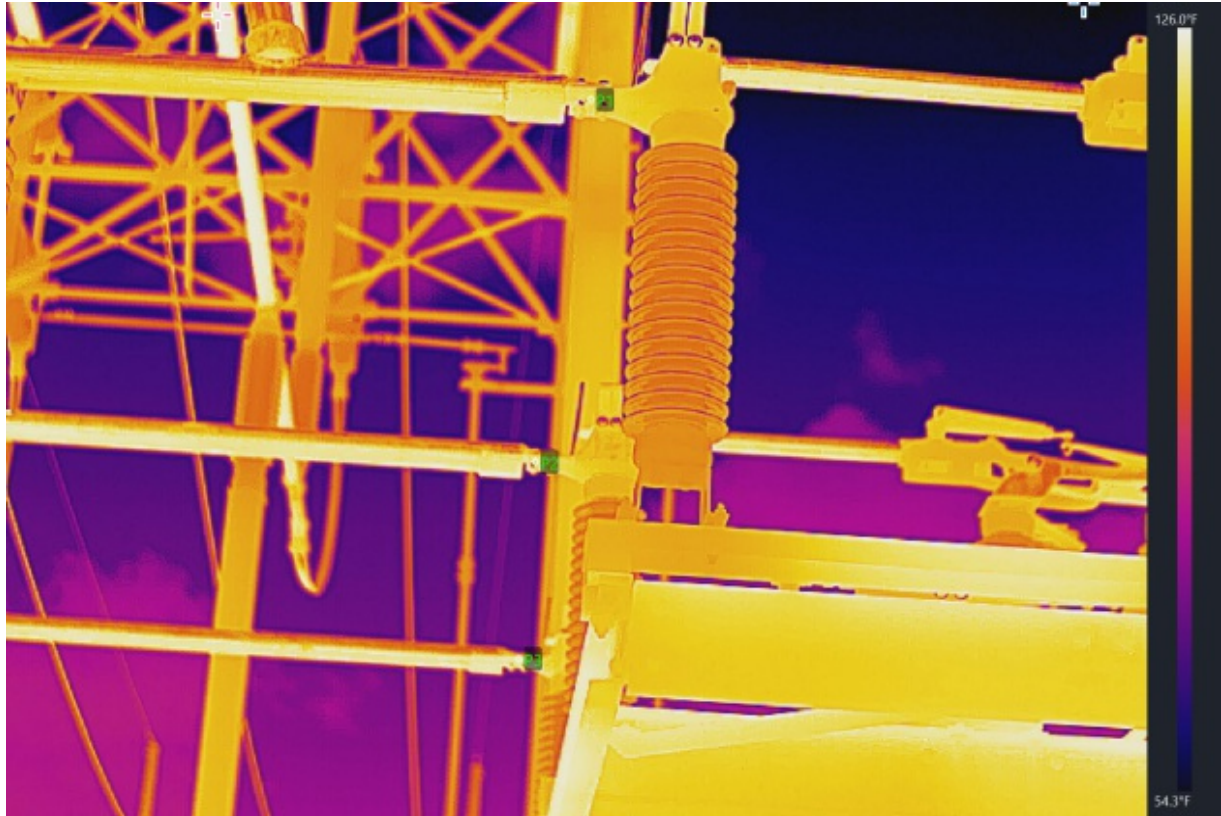

T2 - MAIN AIR SWITCH

Measurements		Image Parameters	
Image:Max. Temp.	126.0°F	Distance	1.5m
Image:Min. Temp.	54.3°F	Humidity	60%
P1	112.5°F	Emissivity	0.97
P2	111.6°F	Reflected Temp.	77.0°F
P3	114.8°F	Atmospheric Temp.	86.3°F

Measurement Parameters		Device Information	
P1:Emissivity	0.97	Device Model	SP60
P1:Reflected Temp.	77.0°F	Device Serial No.	L26310272
P1:Distance	1.5m	Captured At	2023-08-04 02:41:38
P2:Emissivity	0.97		
P2:Reflected Temp.	77.0°F		
P2:Distance	1.5m		
P3:Emissivity	0.97		



T1 - MAIN AIR SWITCH

Measurements		Image Parameters	
Image:Max. Temp.	118.0°F	Distance	1.5m
Image:Min. Temp.	34.0°F	Humidity	60%
P1	105.6°F	Emissivity	0.97
		Reflected Temp.	77.0°F
		Atmospheric Temp.	86.2°F

Measurement Parameters		Device Information	
P1:Emissivity	0.97	Device Model	SP60
P1:Reflected Temp.	77.0°F	Device Serial No.	L26310272
P1:Distance	1.5m	Captured At	2023-08-04 02:40:33

Text Annotation



T1 - MAIN AIR SWITCH

Measurements		Image Parameters	
Image:Max. Temp.	114.8°F	Distance	1.5m
Image:Min. Temp.	21.9°F	Humidity	60%
P1	104.2°F	Emissivity	0.97
		Reflected Temp.	77.0°F
		Atmospheric Temp.	86.2°F

Measurement Parameters		Device Information	
P1:Emissivity	0.97	Device Model	SP60
P1:Reflected Temp.	77.0°F	Device Serial No.	L26310272
P1:Distance	1.5m	Captured At	2023-08-04 02:39:45

Text Annotation

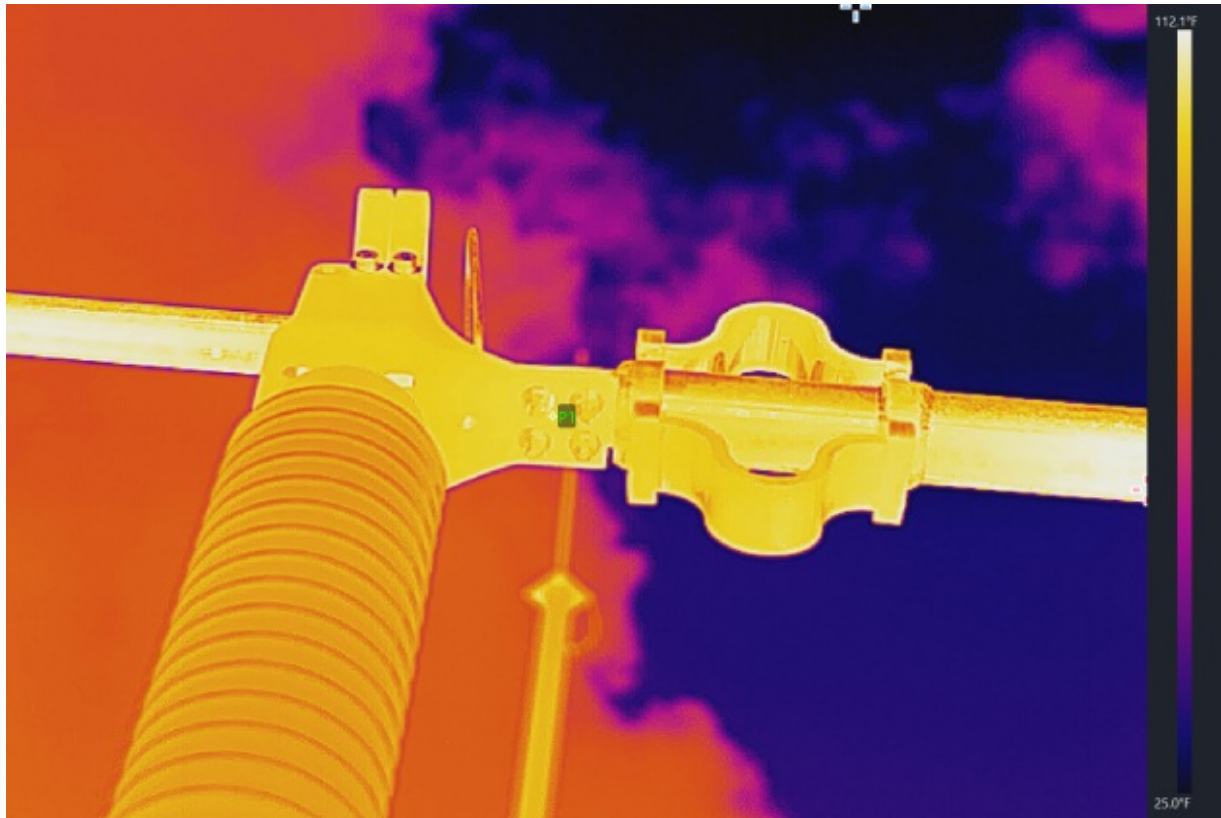

T1 - MAIN AIR SWITCH

Measurements		Image Parameters	
Image:Max. Temp.	112.1°F	Distance	1.5m
Image:Min. Temp.	25.0°F	Humidity	60%
P1	104.5°F	Emissivity	0.97
		Reflected Temp.	77.0°F
		Atmospheric Temp.	86.2°F

Measurement Parameters		Device Information	
P1:Emissivity	0.97	Device Model	SP60
P1:Reflected Temp.	77.0°F	Device Serial No.	L26310272
P1:Distance	1.5m	Captured At	2023-08-04 02:39:14

Text Annotation



T1 - MAIN AIR SWITCH

Measurements		Image Parameters	
Image:Max. Temp.	117.1°F	Distance	1.5m
Image:Min. Temp.	43.9°F	Humidity	60%
P1	106.2°F	Emissivity	0.97
		Reflected Temp.	77.0°F
		Atmospheric Temp.	86.3°F

Measurement Parameters		Device Information	
P1:Emissivity	0.97	Device Model	SP60
P1:Reflected Temp.	77.0°F	Device Serial No.	L26310272
P1:Distance	1.5m	Captured At	2023-08-04 02:38:39

Text Annotation

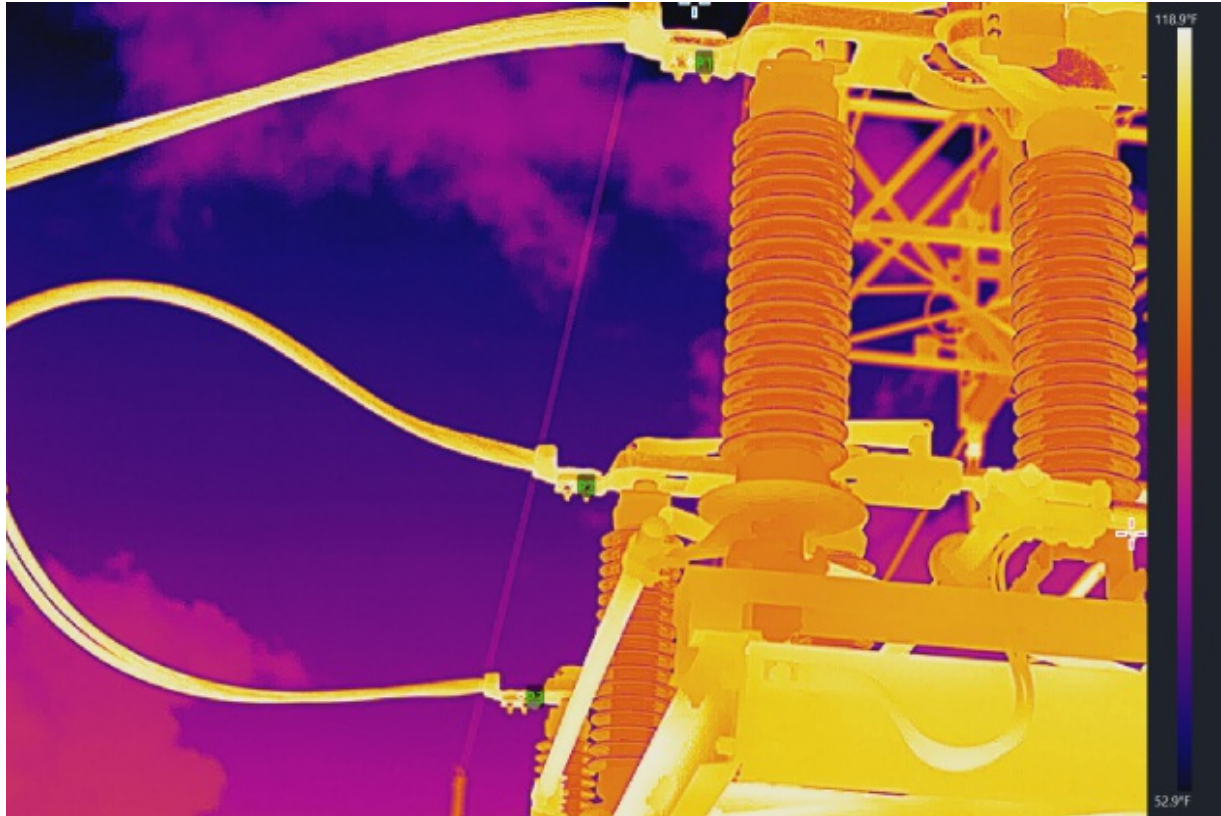

T1 - MAIN AIR SWITCH

Measurements		Image Parameters	
Image:Max. Temp.	118.9°F	Distance	1.5m
Image:Min. Temp.	52.9°F	Humidity	60%
P1	109.9°F	Emissivity	0.97
P2	108.5°F	Reflected Temp.	77.0°F
P3	102.7°F	Atmospheric Temp.	86.3°F

Measurement Parameters		Device Information	
P1:Emissivity	0.97	Device Model	SP60
P1:Reflected Temp.	77.0°F	Device Serial No.	L26310272
P1:Distance	1.5m	Captured At	2023-08-04 02:37:48
P2:Emissivity	0.97		
P2:Reflected Temp.	77.0°F		
P2:Distance	1.5m		
P3:Emissivity	0.97		

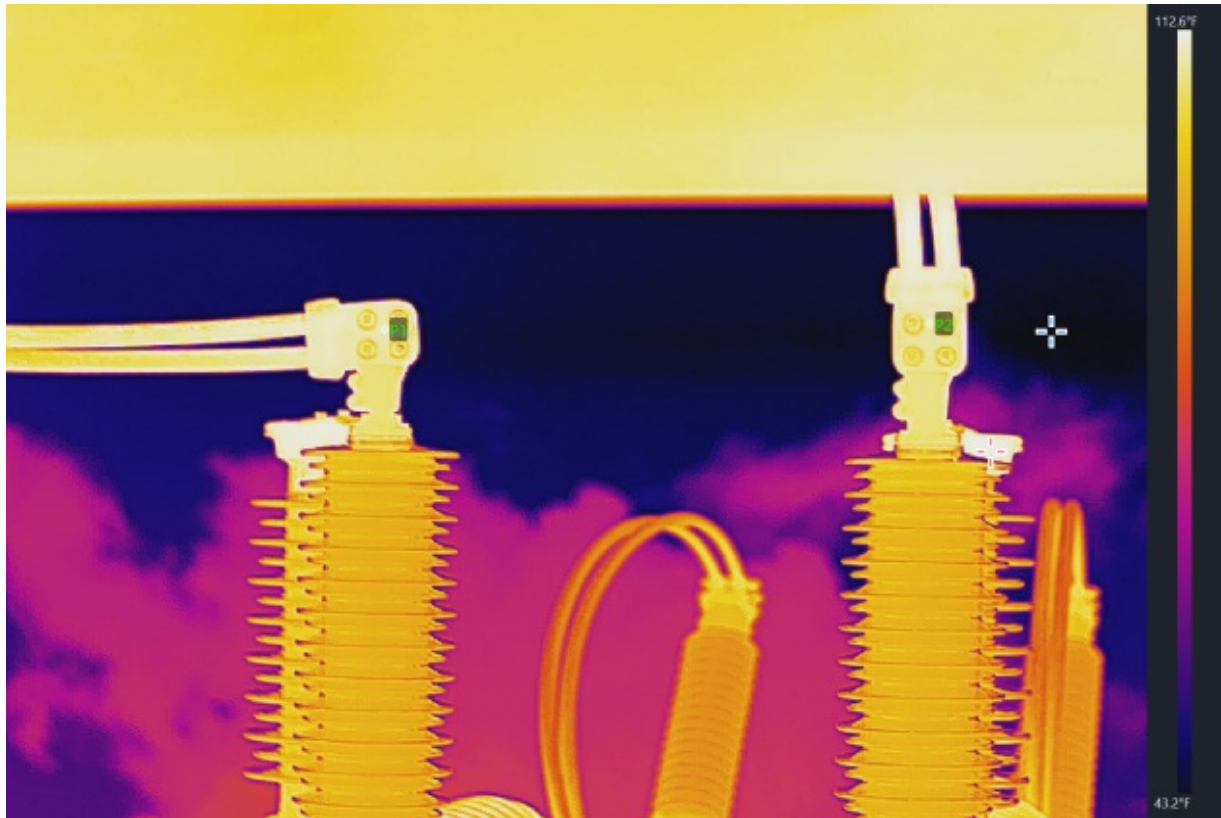

52-L1 - SF6 BREAKER

Measurements		Image Parameters	
Image:Max. Temp.	112.6°F	Distance	1.5m
Image:Min. Temp.	43.2°F	Humidity	60%
P1	109.8°F	Emissivity	0.97
P2	109.8°F	Reflected Temp.	77.0°F
		Atmospheric Temp.	86.3°F

Measurement Parameters		Device Information	
P1:Emissivity	0.97	Device Model	SP60
P1:Reflected Temp.	77.0°F	Device Serial No.	L26310272
P1:Distance	1.5m	Captured At	2023-08-04 02:37:01
P2:Emissivity	0.97		
P2:Reflected Temp.	77.0°F		
P2:Distance	1.5m		



52-L1 - SF6 BREAKER

Measurements		Image Parameters	
Image:Max. Temp.	113.4°F	Distance	1.5m
Image:Min. Temp.	43.0°F	Humidity	60%
P1	109.2°F	Emissivity	0.97
P2	111.7°F	Reflected Temp.	77.0°F
		Atmospheric Temp.	86.3°F

Measurement Parameters		Device Information	
P1:Emissivity	0.97	Device Model	SP60
P1:Reflected Temp.	77.0°F	Device Serial No.	L26310272
P1:Distance	1.5m	Captured At	2023-08-04 02:36:53
P2:Emissivity	0.97		
P2:Reflected Temp.	77.0°F		
P2:Distance	1.5m		

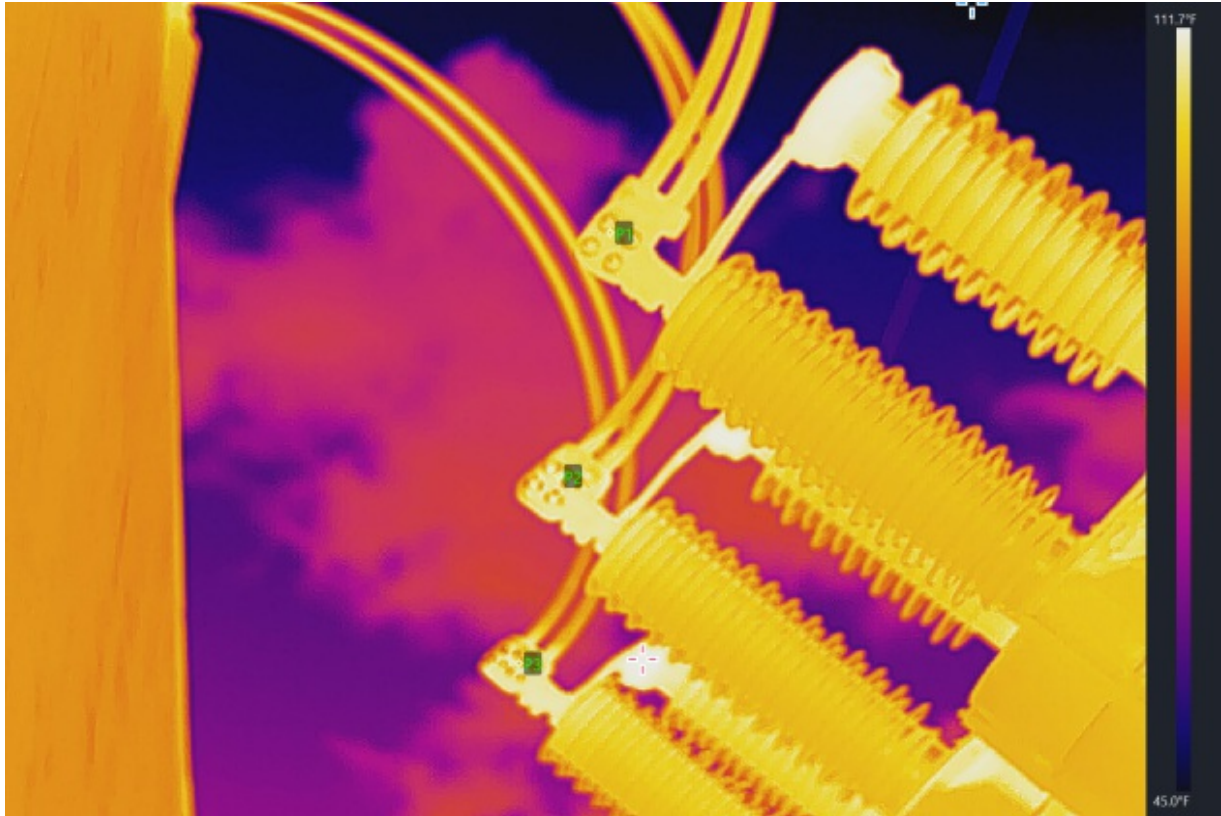

52-L1 - SF6 BREAKER

Measurements		Image Parameters	
Image:Max. Temp.	111.7°F	Distance	1.5m
Image:Min. Temp.	45.0°F	Humidity	60%
P1	102.2°F	Emissivity	0.97
P2	104.5°F	Reflected Temp.	77.0°F
P3	99.5°F	Atmospheric Temp.	86.3°F

Measurement Parameters		Device Information	
P1:Emissivity	0.97	Device Model	SP60
P1:Reflected Temp.	77.0°F	Device Serial No.	L26310272
P1:Distance	1.5m	Captured At	2023-08-04 02:35:09
P2:Emissivity	0.97		
P2:Reflected Temp.	77.0°F		
P2:Distance	1.5m		
P3:Emissivity	0.97		

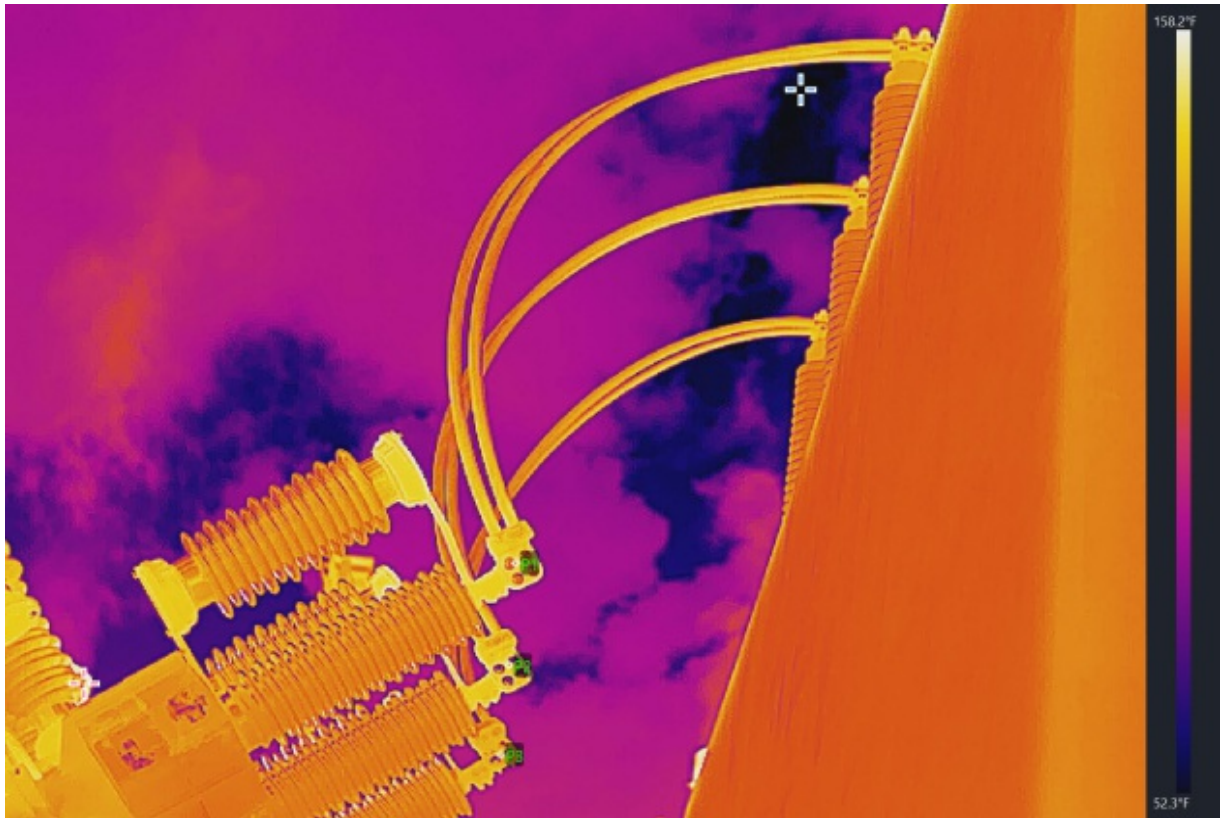

52-L1 - SF6 BREAKER

Measurements		Image Parameters	
Image:Max. Temp.	158.2°F	Distance	1.5m
Image:Min. Temp.	52.3°F	Humidity	60%
P1	104.2°F	Emissivity	0.97
P2	104.2°F	Reflected Temp.	77.0°F
P3	99.7°F	Atmospheric Temp.	86.2°F

Measurement Parameters		Device Information	
P1:Emissivity	0.97	Device Model	SP60
P1:Reflected Temp.	77.0°F	Device Serial No.	L26310272
P1:Distance	1.5m	Captured At	2023-08-04 02:34:46
P2:Emissivity	0.97		
P2:Reflected Temp.	77.0°F		
P2:Distance	1.5m		
P3:Emissivity	0.97		



T1-GSU - HIGH SIDE BUSHINGS

Measurements		Image Parameters	
Image:Max. Temp.	132.3°F	Distance	1.5m
Image:Min. Temp.	50.5°F	Humidity	60%
P1	103.8°F	Emissivity	0.97
P2	115.5°F	Reflected Temp.	77.0°F
		Atmospheric Temp.	86.2°F

Measurement Parameters		Device Information	
P1:Emissivity	0.97	Device Model	SP60
P1:Reflected Temp.	77.0°F	Device Serial No.	L26310272
P1:Distance	1.5m	Captured At	2023-08-04 02:33:55
P2:Emissivity	0.97		
P2:Reflected Temp.	77.0°F		
P2:Distance	1.5m		



T1-GSU - HIGH SIDE BUSHINGS

Measurements		Image Parameters	
Image:Max. Temp.	133.5°F	Distance	1.5m
Image:Min. Temp.	52.9°F	Humidity	60%
P1	103.8°F	Emissivity	0.97
P2	108.7°F	Reflected Temp.	77.0°F
		Atmospheric Temp.	86.3°F

Measurement Parameters		Device Information	
P1:Emissivity	0.97	Device Model	SP60
P1:Reflected Temp.	77.0°F	Device Serial No.	L26310272
P1:Distance	1.5m	Captured At	2023-08-04 02:33:23
P2:Emissivity	0.97		
P2:Reflected Temp.	77.0°F		
P2:Distance	1.5m		



52-L1 - SF6 BREAKER

Measurements		Image Parameters	
Image:Max. Temp.	113.4°F	Distance	1.5m
Image:Min. Temp.	44.6°F	Humidity	60%
P1	105.8°F	Emissivity	0.97
P2	106.9°F	Reflected Temp.	77.0°F
P3	104.4°F	Atmospheric Temp.	86.2°F

Measurement Parameters		Device Information	
P1:Emissivity	0.97	Device Model	SP60
P1:Reflected Temp.	77.0°F	Device Serial No.	L26310272
P1:Distance	1.5m	Captured At	2023-08-04 02:31:53
P2:Emissivity	0.97		
P2:Reflected Temp.	77.0°F		
P2:Distance	1.5m		
P3:Emissivity	0.97		



Orange Cogen
Test Reports
Pre-Outage - IR Scanning
Job #OCFL2310067



Empowering Electrical Infrastructure
for a Sustainable Future



Testing and Commissioning Services

6625 Network Way, Indianapolis, IN 46278

www.hva-inc.com/pc-field-services/

Orange Cogen
1901 S. Clear Springs Rd
Bartow, FL 33830

David Courson,

We are pleased to present the field test reports for the IR scanning pre-outage conducted by High Voltage Advanced. This report highlights the comprehensive analysis and results obtained during the field-testing phase, providing valuable insights into the performance and reliability of your electrical system under evaluation.

At HVA, we strive to deliver exceptional products and services, backed by rigorous testing and analysis. We understand the significance of the field test results in evaluating the effectiveness and safety of your electrical system. The information contained in this report is intended to provide you with a detailed overview of the performance characteristics, environmental considerations, and any observed issues during the testing phase.

Key Sections of the Field Test Report:

- **Equipment Tested:** all equipment that was tested during the field-testing phase.
- **Scope of Work:** Detailed explanation of the goals and objectives of the field test.
- **Observations and Recommendations:** Identification of any observed issues or challenges, accompanied by recommendations for improvement or further investigations, if necessary.
- **Results:** In-depth examination of the obtained data, including test data sheets, system behavior, and any deviations from expected outcomes at the time of testing.

We understand that your valuable feedback is crucial in our continuous efforts to enhance our offerings. Therefore, we encourage you to review the field test report thoroughly and reach out to us with any questions or concerns you may have. Our dedicated team of experts is available to provide further clarification or address any questions you may have.

We sincerely appreciate the opportunity to collaborate with you on this project and remain committed to delivering the highest quality solutions to meet your needs. Should you require any additional information or assistance, please do not hesitate to contact us.

Thank you for your trust and continued partnership.

Sincerely,

Matthew Falchetti

Lead Technician

NICET I #153748

Cell: (863)528-4124

HVA - P&C / Field Services

matt.falchetti@hva-inc.com

www.hva-inc.com/pc-field-services/



Chris Roehm

Field Services Manager

NICET III #152740

Cell: (843)818-8847

HVA - P&C / Field Services

chris.roehm@hva-inc.com

www.hva-inc.com/pc-field-services/





Testing and Commissioning Services

6625 Network Way, Indianapolis, IN 46278

www.hva-inc.com/pc-field-services/

Equipment Tested: Switch-yard and buss duct

Scope of Work: IR scan Pre-outage

Observations and Recommendations:

Results: Good - no hot spots

Thermography Report

Client	Orange Cogen
Address	Bartow, Florida
Date	8/4/2023
Inspector	Andrew Kirk

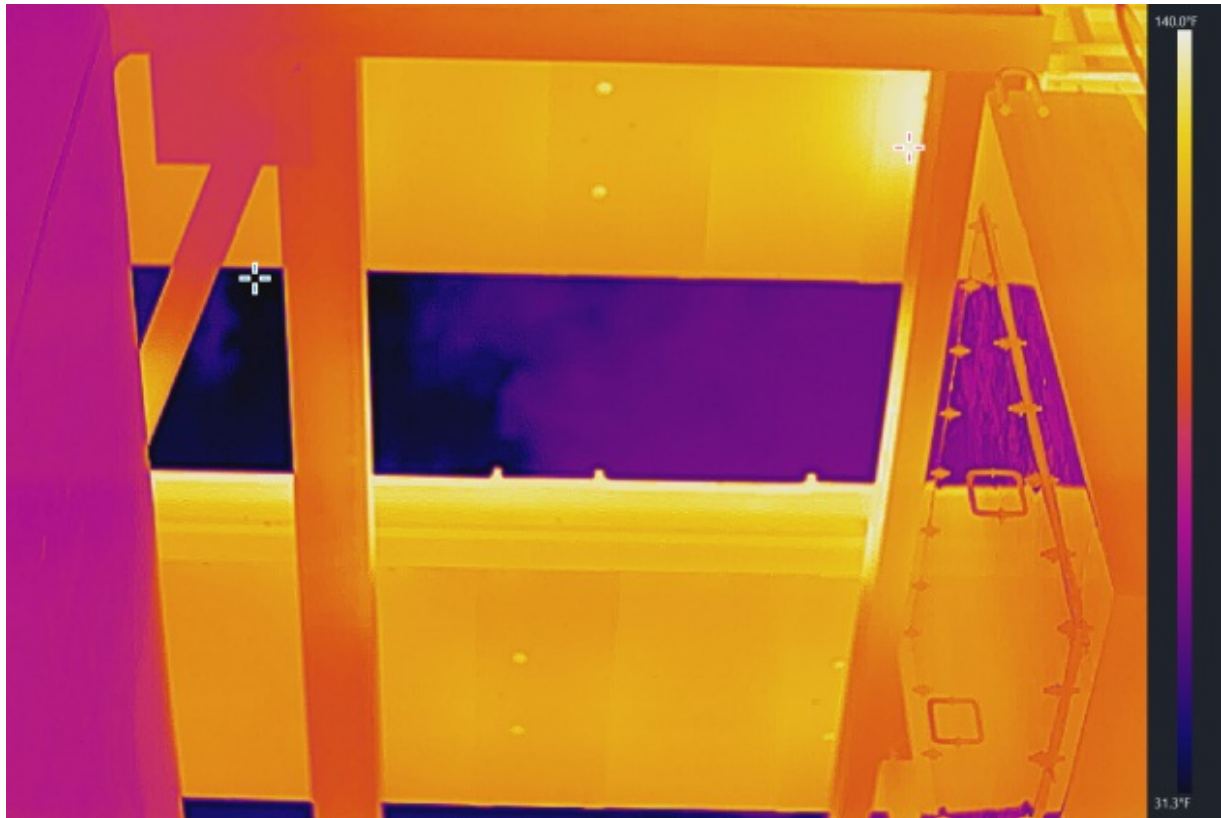

BUS DUCT HEATERS

Measurements		Image Parameters	
Image:Max. Temp.	140.0°F	Distance	1.5m
Image:Min. Temp.	31.3°F	Humidity	60%
		Emissivity	0.97
		Reflected Temp.	77.0°F
		Atmospheric Temp.	92.0°F
Measurement Parameters		Device Information	
		Device Model	SP60
		Device Serial No.	L26310272
		Captured At	2023-08-04 03:08:58
Text Annotation			

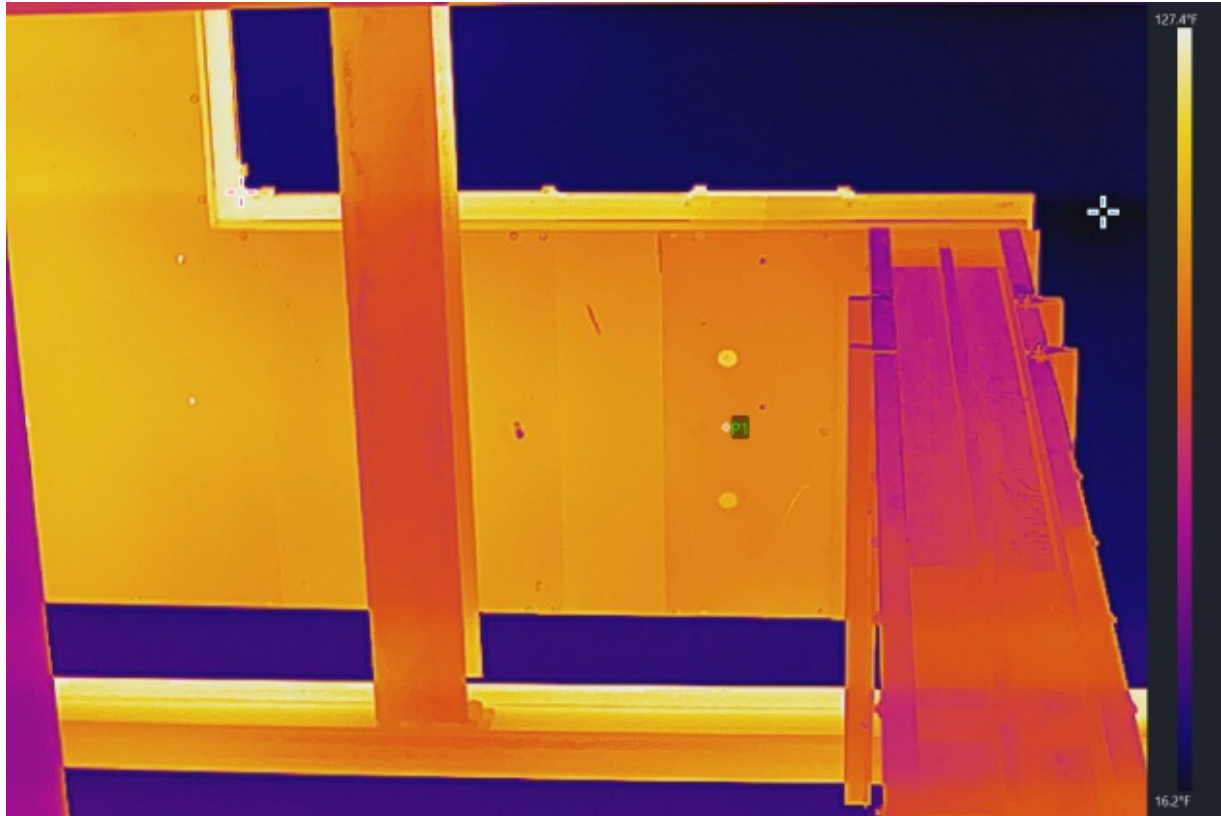

BUS DUCT HEATERS

Measurements		Image Parameters	
Image:Max. Temp.	127.4°F	Distance	1.5m
Image:Min. Temp.	16.2°F	Humidity	60%
P1	105.6°F	Emissivity	0.97
		Reflected Temp.	77.0°F
		Atmospheric Temp.	91.8°F

Measurement Parameters		Device Information	
P1:Emissivity	0.97	Device Model	SP60
P1:Reflected Temp.	77.0°F	Device Serial No.	L26310272
P1:Distance	1.5m	Captured At	2023-08-04 03:08:04

Text Annotation

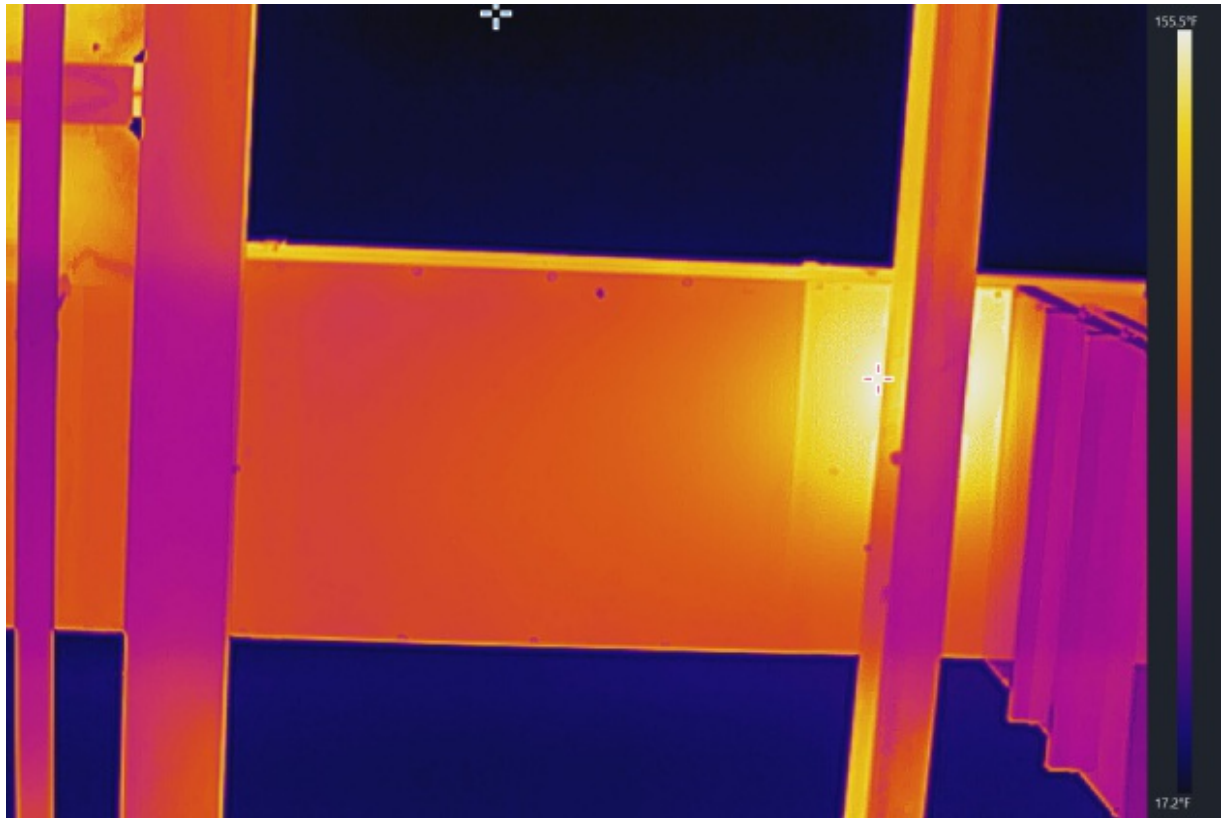

BUS DUCT HEATERS

Measurements		Image Parameters	
Image:Max. Temp.	155.5°F	Distance	1.5m
Image:Min. Temp.	17.2°F	Humidity	60%
		Emissivity	0.97
		Reflected Temp.	77.0°F
		Atmospheric Temp.	91.7°F
Measurement Parameters		Device Information	
		Device Model	SP60
		Device Serial No.	L26310272
		Captured At	2023-08-04 03:07:25
Text Annotation			

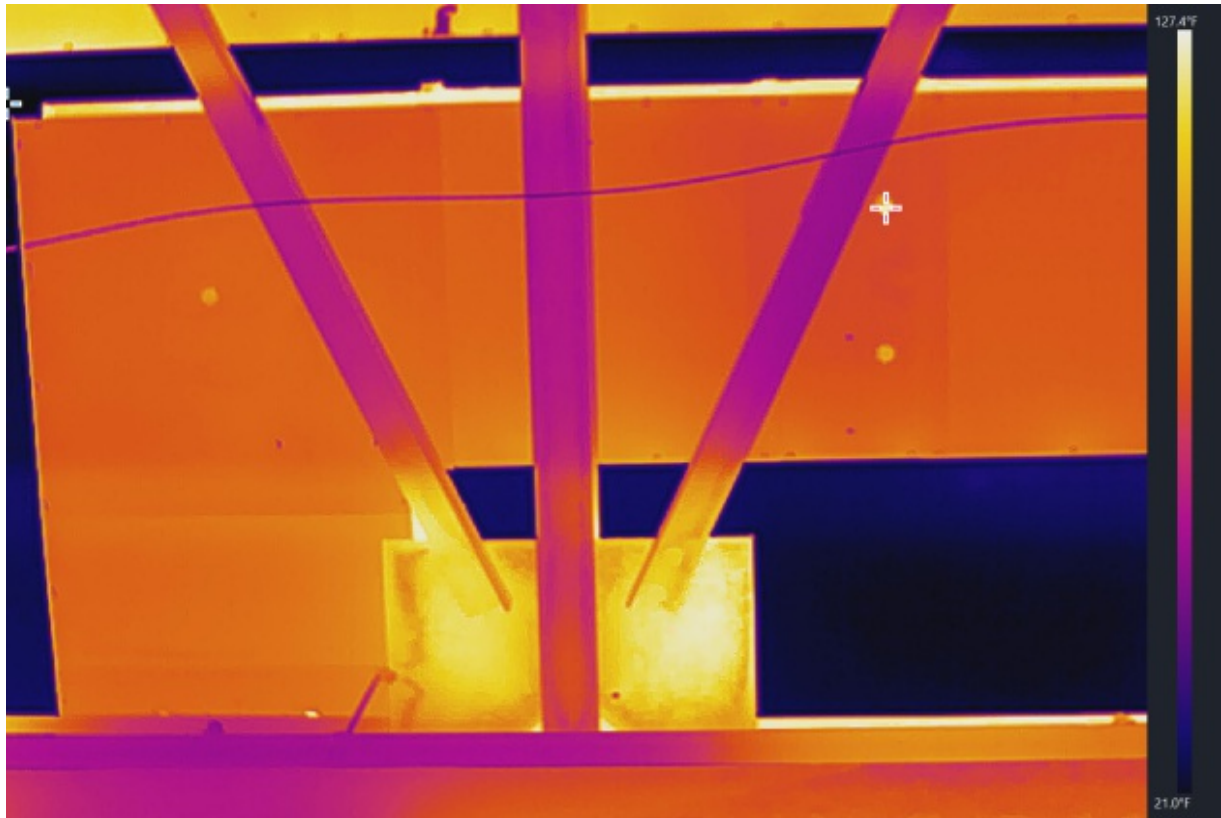

BUS DUCT HEATERS

Measurements		Image Parameters	
Image:Max. Temp.	127.4°F	Distance	1.5m
Image:Min. Temp.	21.0°F	Humidity	60%
		Emissivity	0.97
		Reflected Temp.	77.0°F
		Atmospheric Temp.	91.8°F
Measurement Parameters		Device Information	
		Device Model	SP60
		Device Serial No.	L26310272
		Captured At	2023-08-04 03:07:12
Text Annotation			

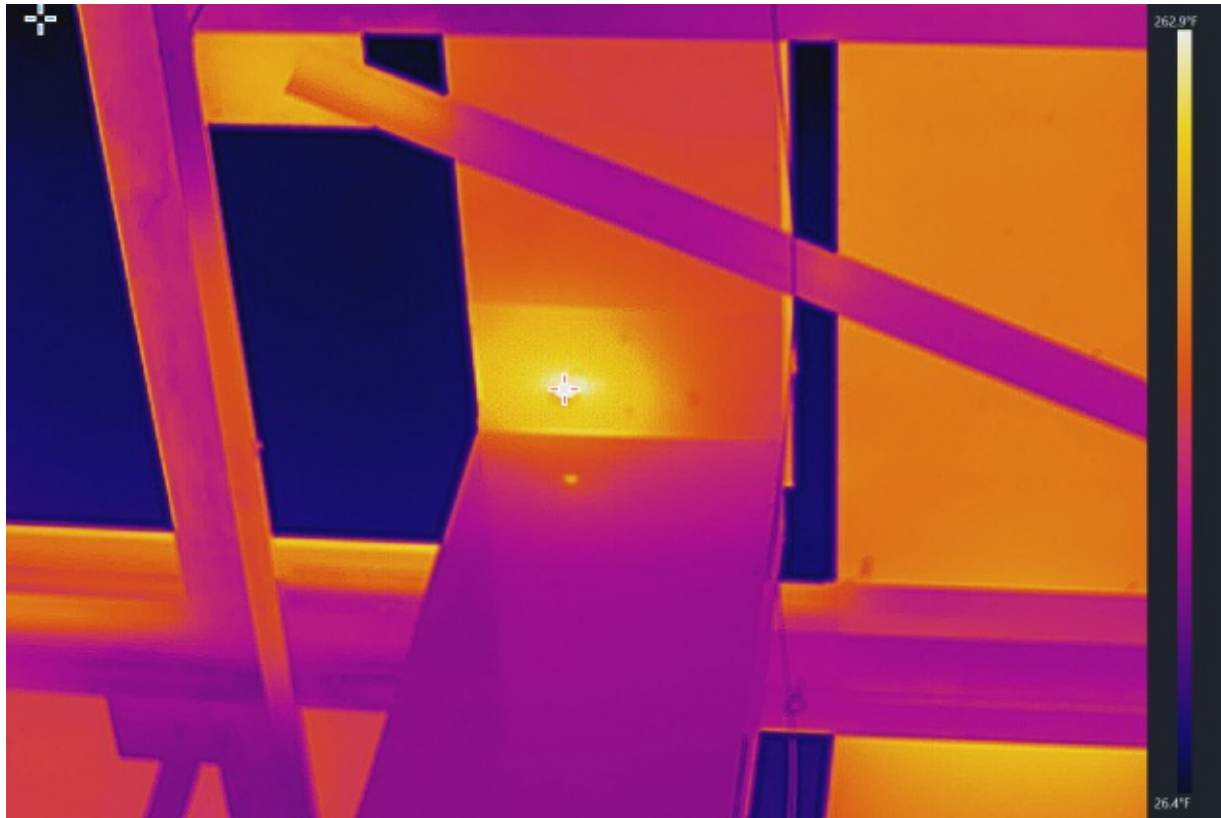

BUS DUCT HEATERS

Measurements		Image Parameters	
Image:Max. Temp.	262.9°F	Distance	1.5m
Image:Min. Temp.	26.4°F	Humidity	60%
		Emissivity	0.97
		Reflected Temp.	77.0°F
		Atmospheric Temp.	91.9°F
Measurement Parameters		Device Information	
		Device Model	SP60
		Device Serial No.	L26310272
		Captured At	2023-08-04 03:07:02
Text Annotation			

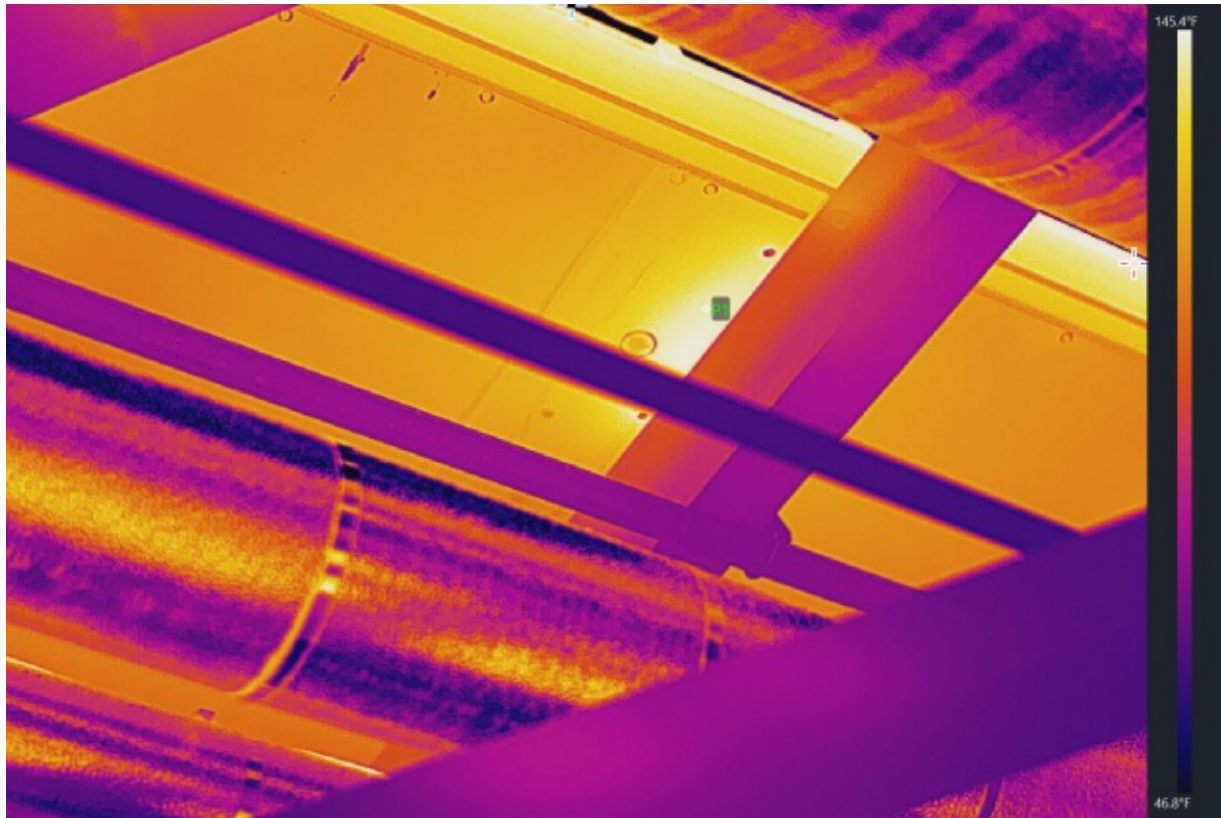

BUS DUCT HEATERS

Measurements		Image Parameters	
Image:Max. Temp.	145.4°F	Distance	1.5m
Image:Min. Temp.	46.8°F	Humidity	60%
P1	140.7°F	Emissivity	0.97
		Reflected Temp.	77.0°F
		Atmospheric Temp.	92.2°F

Measurement Parameters		Device Information	
P1:Emissivity	0.97	Device Model	SP60
P1:Reflected Temp.	77.0°F	Device Serial No.	L26310272
P1:Distance	1.5m	Captured At	2023-08-04 03:04:34

Text Annotation

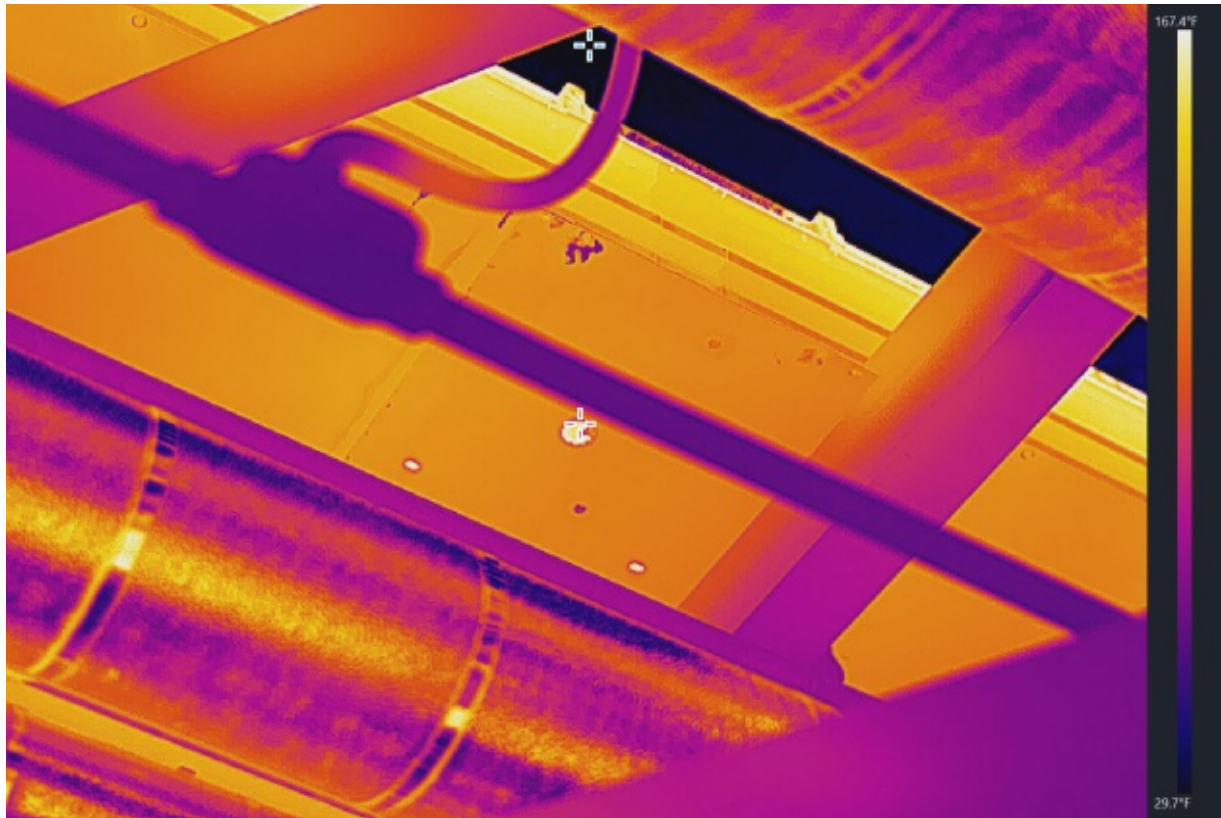

BUS DUCT HEATERS

Measurements		Image Parameters	
Image:Max. Temp.	167.4°F	Distance	1.5m
Image:Min. Temp.	29.7°F	Humidity	60%
		Emissivity	0.97
		Reflected Temp.	77.0°F
		Atmospheric Temp.	92.0°F

Measurement Parameters		Device Information	
		Device Model	SP60
		Device Serial No.	L26310272
		Captured At	2023-08-04 03:04:13

Text Annotation

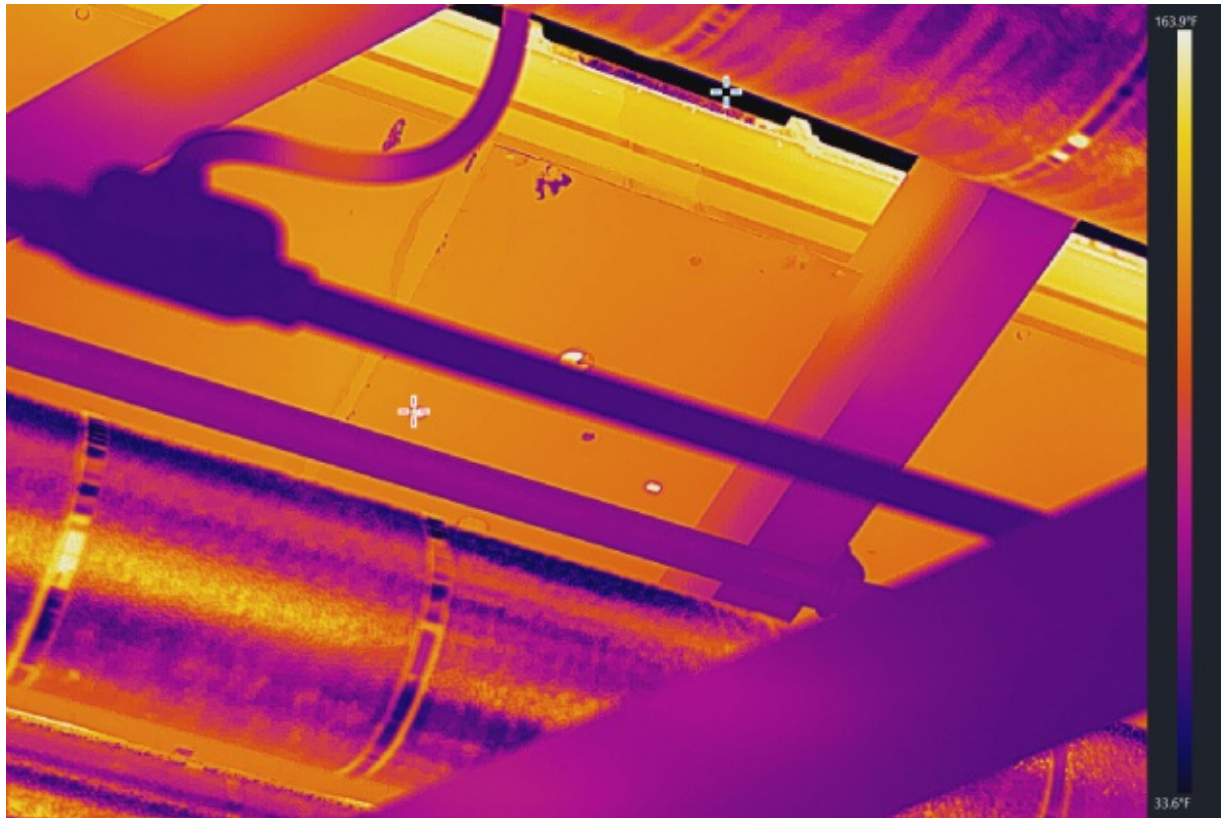

BUS DUCT HEATERS

Measurements		Image Parameters	
Image:Max. Temp.	163.9°F	Distance	1.5m
Image:Min. Temp.	33.6°F	Humidity	60%
		Emissivity	0.97
		Reflected Temp.	77.0°F
		Atmospheric Temp.	91.9°F
Measurement Parameters		Device Information	
		Device Model	SP60
		Device Serial No.	L26310272
		Captured At	2023-08-04 03:04:07
Text Annotation			

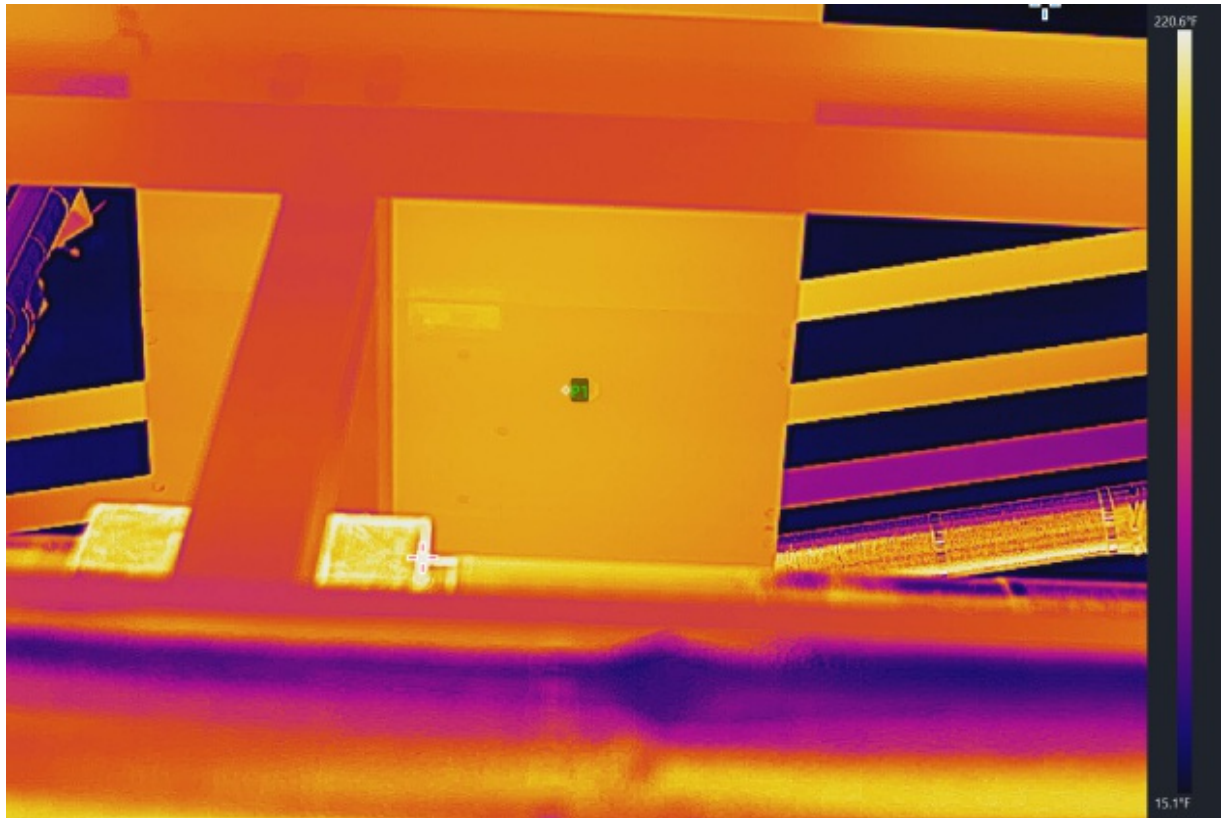

BUS DUCT HEATERS

Measurements		Image Parameters	
Image:Max. Temp.	220.6°F	Distance	1.5m
Image:Min. Temp.	15.1°F	Humidity	60%
P1	118.0°F	Emissivity	0.97
		Reflected Temp.	77.0°F
		Atmospheric Temp.	91.4°F

Measurement Parameters		Device Information	
P1:Emissivity	0.97	Device Model	SP60
P1:Reflected Temp.	77.0°F	Device Serial No.	L26310272
P1:Distance	1.5m	Captured At	2023-08-04 03:03:18

Text Annotation

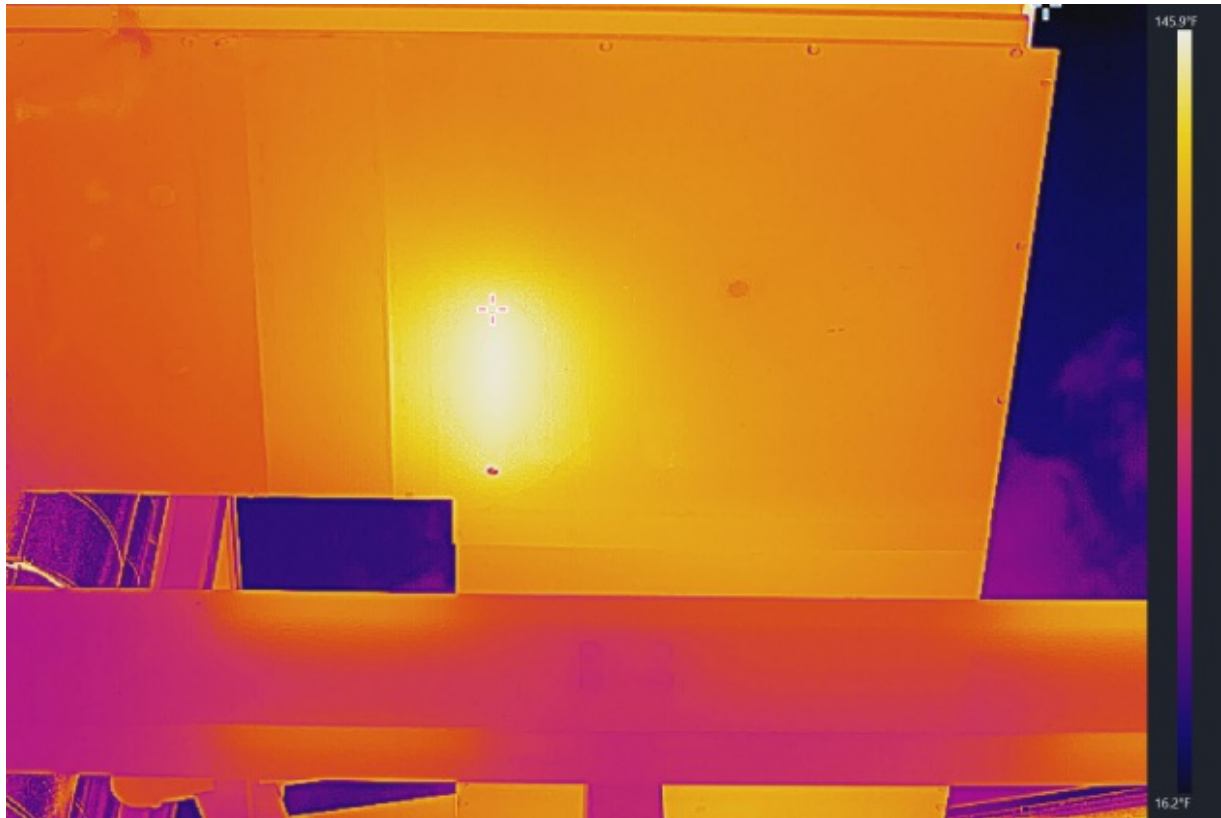

BUS DUCT HEATERS

Measurements		Image Parameters	
Image:Max. Temp.	145.9°F	Distance	1.5m
Image:Min. Temp.	16.2°F	Humidity	60%
		Emissivity	0.97
		Reflected Temp.	77.0°F
		Atmospheric Temp.	91.4°F
Measurement Parameters		Device Information	
		Device Model	SP60
		Device Serial No.	L26310272
		Captured At	2023-08-04 03:03:04
Text Annotation			

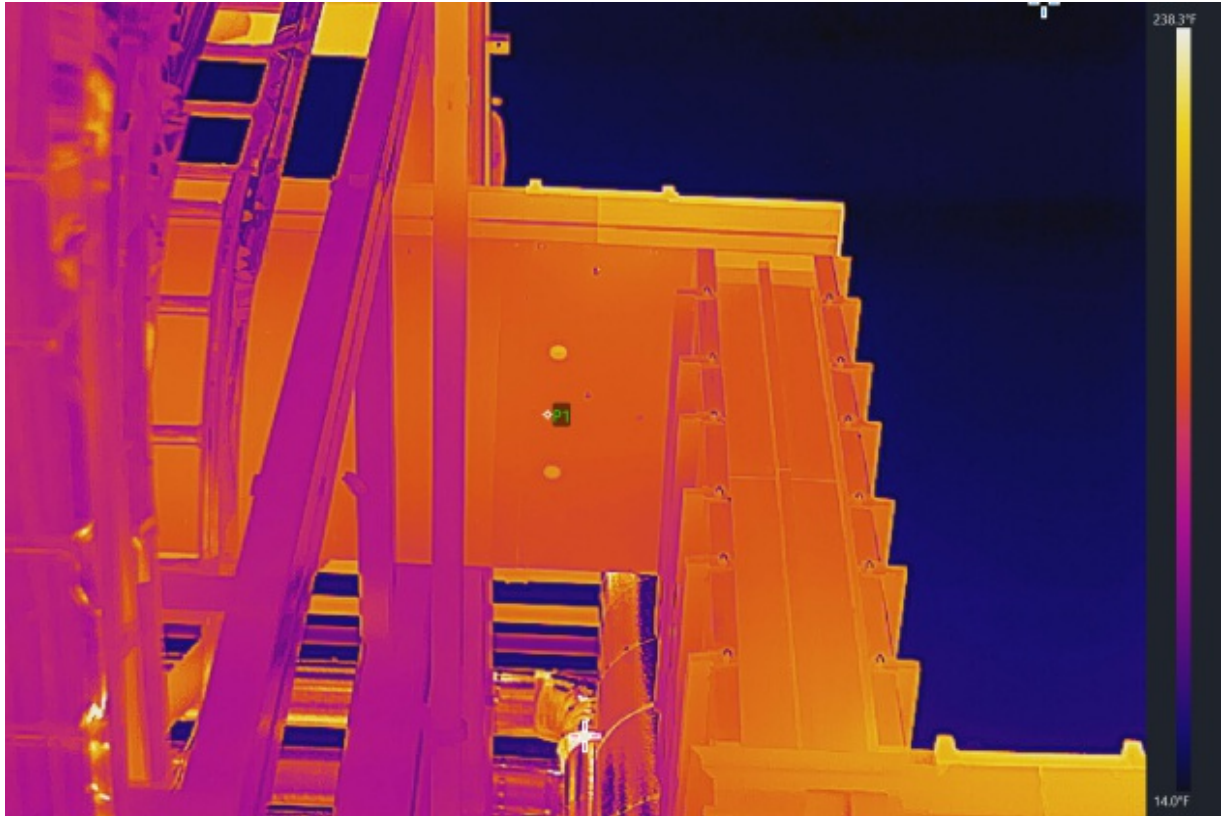

BUS DUCT HEATERS

Measurements		Image Parameters	
Image:Max. Temp.	238.3°F	Distance	1.5m
Image:Min. Temp.	14.0°F	Humidity	60%
P1	104.5°F	Emissivity	0.97
		Reflected Temp.	77.0°F
		Atmospheric Temp.	91.4°F

Measurement Parameters		Device Information	
P1:Emissivity	0.97	Device Model	SP60
P1:Reflected Temp.	77.0°F	Device Serial No.	L26310272
P1:Distance	1.5m	Captured At	2023-08-04 03:02:45

Text Annotation

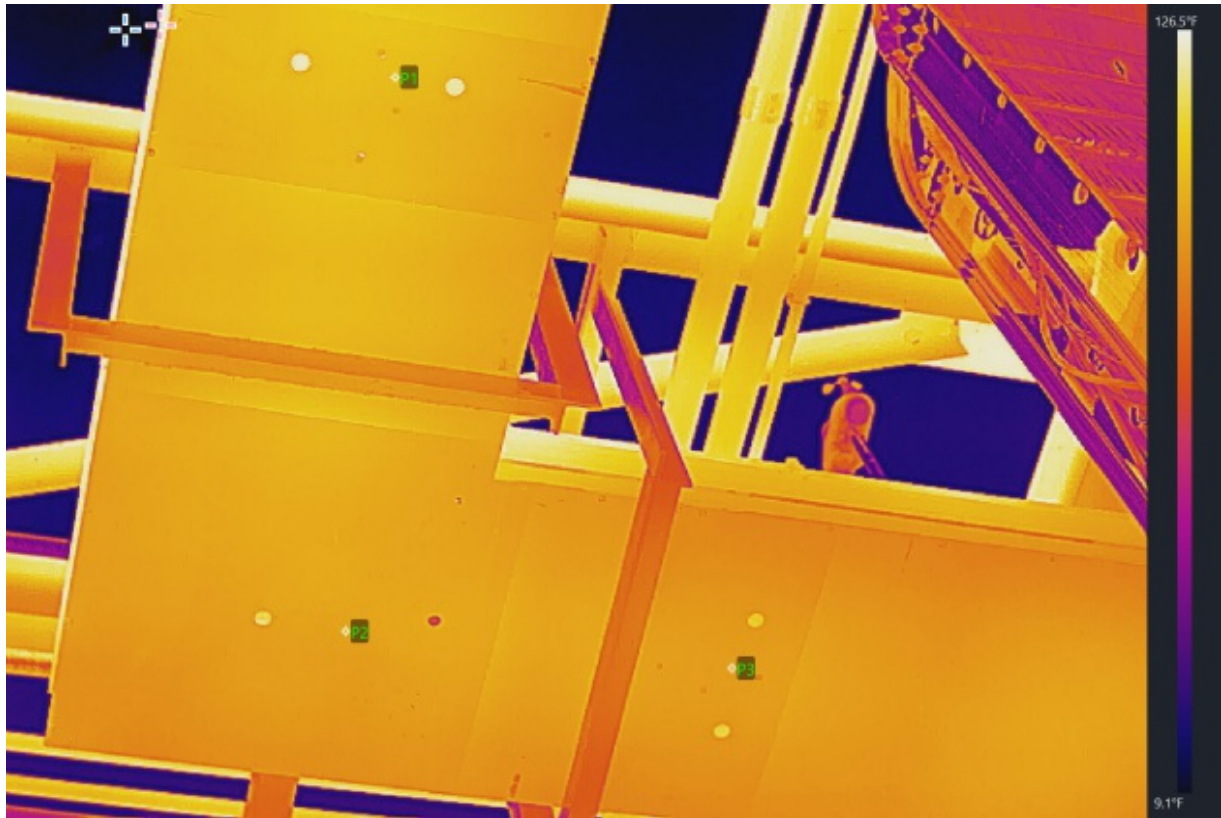

BUS DUCT HEATERS

Measurements		Image Parameters	
Image:Max. Temp.	126.5°F	Distance	1.5m
Image:Min. Temp.	9.1°F	Humidity	60%
P1	110.3°F	Emissivity	0.97
P2	107.4°F	Reflected Temp.	77.0°F
P3	106.5°F	Atmospheric Temp.	91.4°F

Measurement Parameters		Device Information	
P1:Emissivity	0.97	Device Model	SP60
P1:Reflected Temp.	77.0°F	Device Serial No.	L26310272
P1:Distance	1.5m	Captured At	2023-08-04 03:02:32
P2:Emissivity	0.97		
P2:Reflected Temp.	77.0°F		
P2:Distance	1.5m		
P3:Emissivity	0.97		

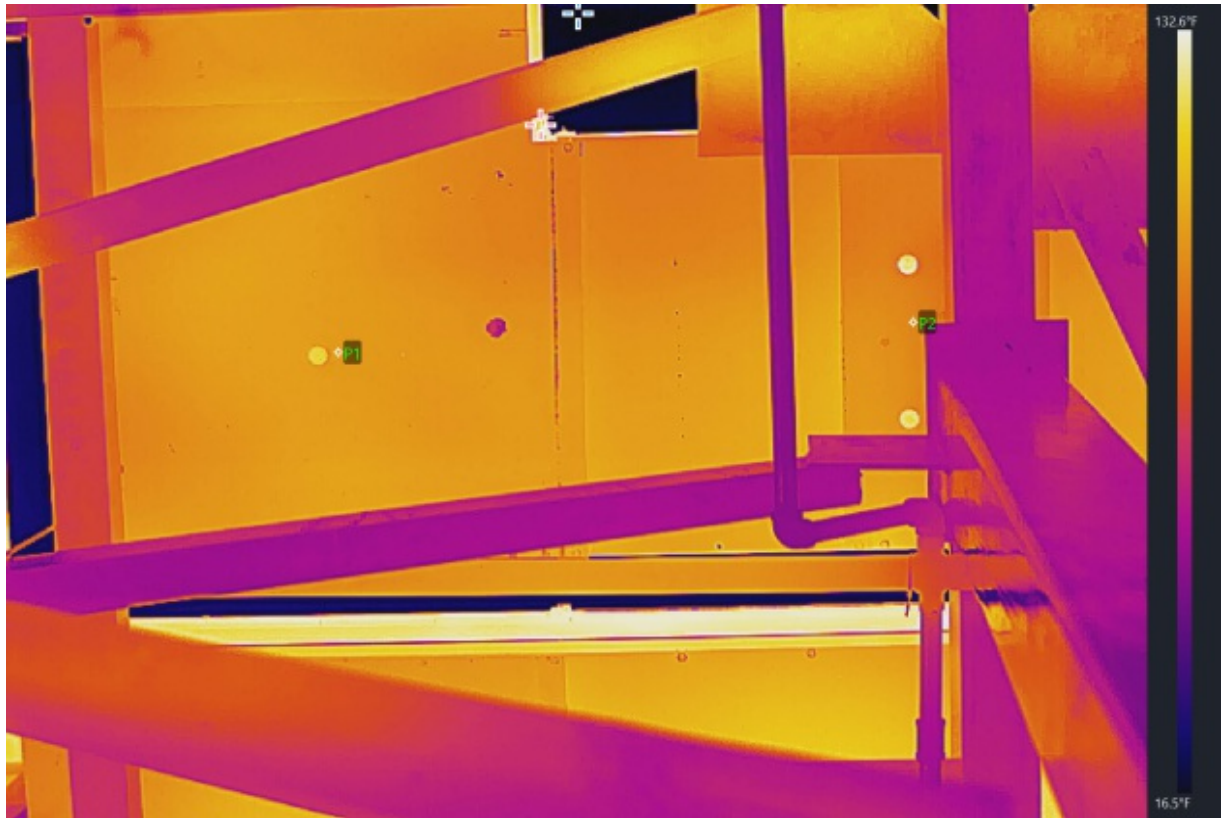

BUS DUCT HEATERS

Measurements		Image Parameters	
Image:Max. Temp.	132.6°F	Distance	1.5m
Image:Min. Temp.	16.5°F	Humidity	60%
P1	111.7°F	Emissivity	0.97
P2	109.6°F	Reflected Temp.	77.0°F
		Atmospheric Temp.	91.5°F

Measurement Parameters		Device Information	
P1:Emissivity	0.97	Device Model	SP60
P1:Reflected Temp.	77.0°F	Device Serial No.	L26310272
P1:Distance	1.5m	Captured At	2023-08-04 03:02:20
P2:Emissivity	0.97		
P2:Reflected Temp.	77.0°F		
P2:Distance	1.5m		

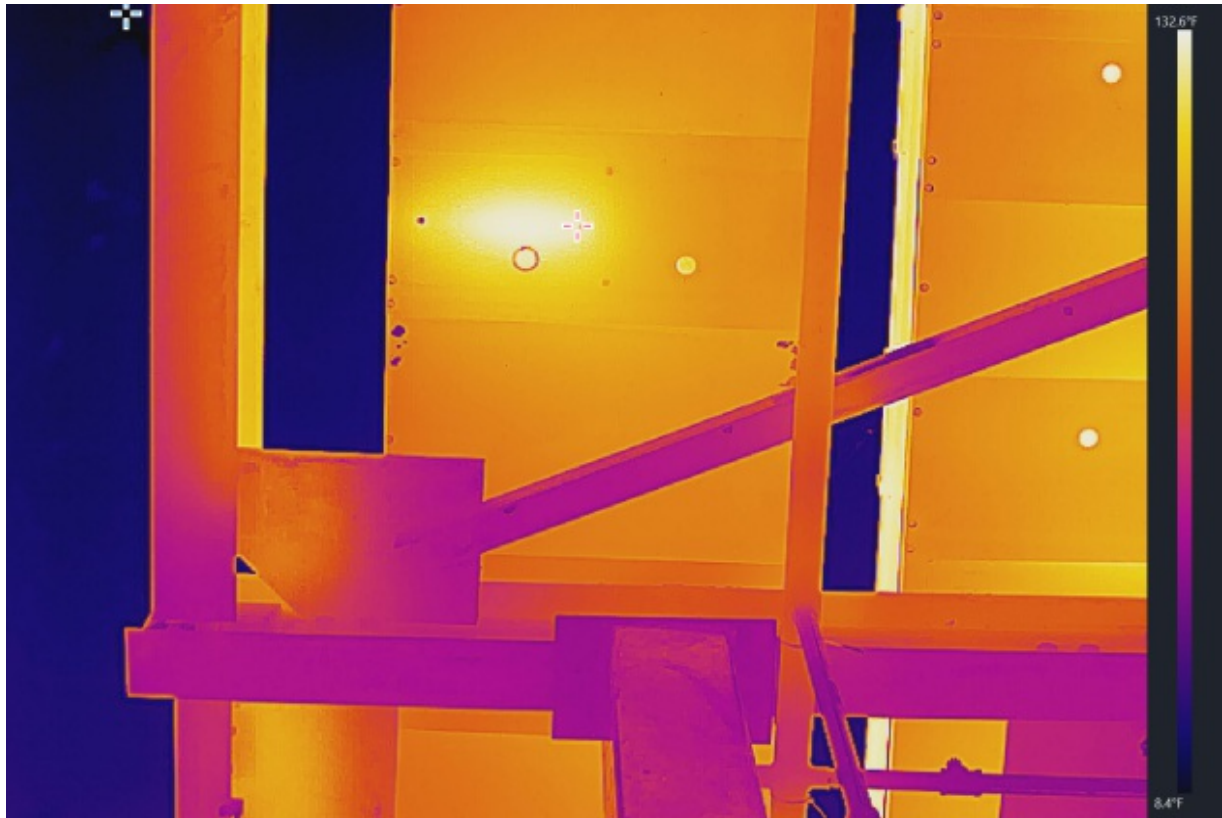

BUS DUCT HEATERS

Measurements		Image Parameters	
Image:Max. Temp.	132.6°F	Distance	1.5m
Image:Min. Temp.	8.4°F	Humidity	60%
		Emissivity	0.97
		Reflected Temp.	77.0°F
		Atmospheric Temp.	91.5°F

Measurement Parameters		Device Information	
		Device Model	SP60
		Device Serial No.	L26310272
		Captured At	2023-08-04 03:02:09

Text Annotation

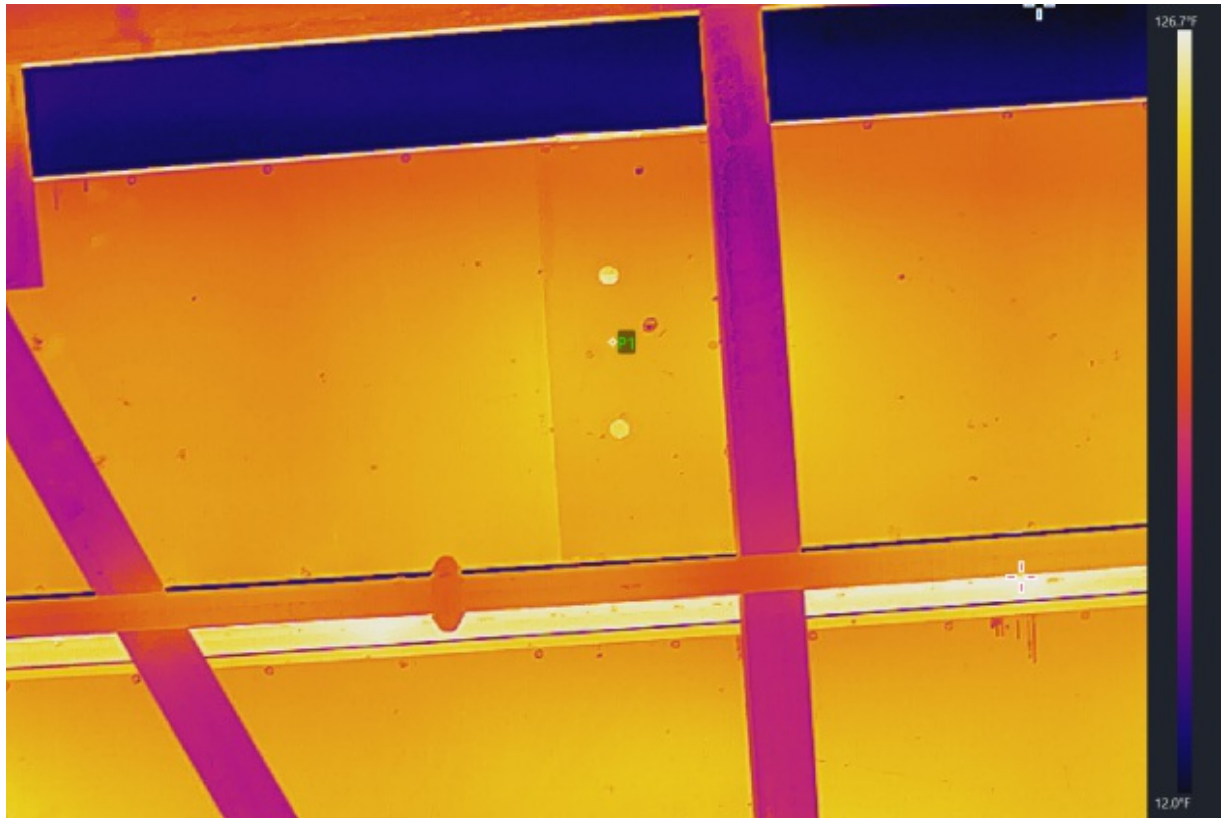

BUS DUCT HEATERS

Measurements		Image Parameters	
Image:Max. Temp.	126.7°F	Distance	1.5m
Image:Min. Temp.	12.0°F	Humidity	60%
P1	114.4°F	Emissivity	0.97
		Reflected Temp.	77.0°F
		Atmospheric Temp.	91.5°F

Measurement Parameters		Device Information	
P1:Emissivity	0.97	Device Model	SP60
P1:Reflected Temp.	77.0°F	Device Serial No.	L26310272
P1:Distance	1.5m	Captured At	2023-08-04 03:02:00

Text Annotation

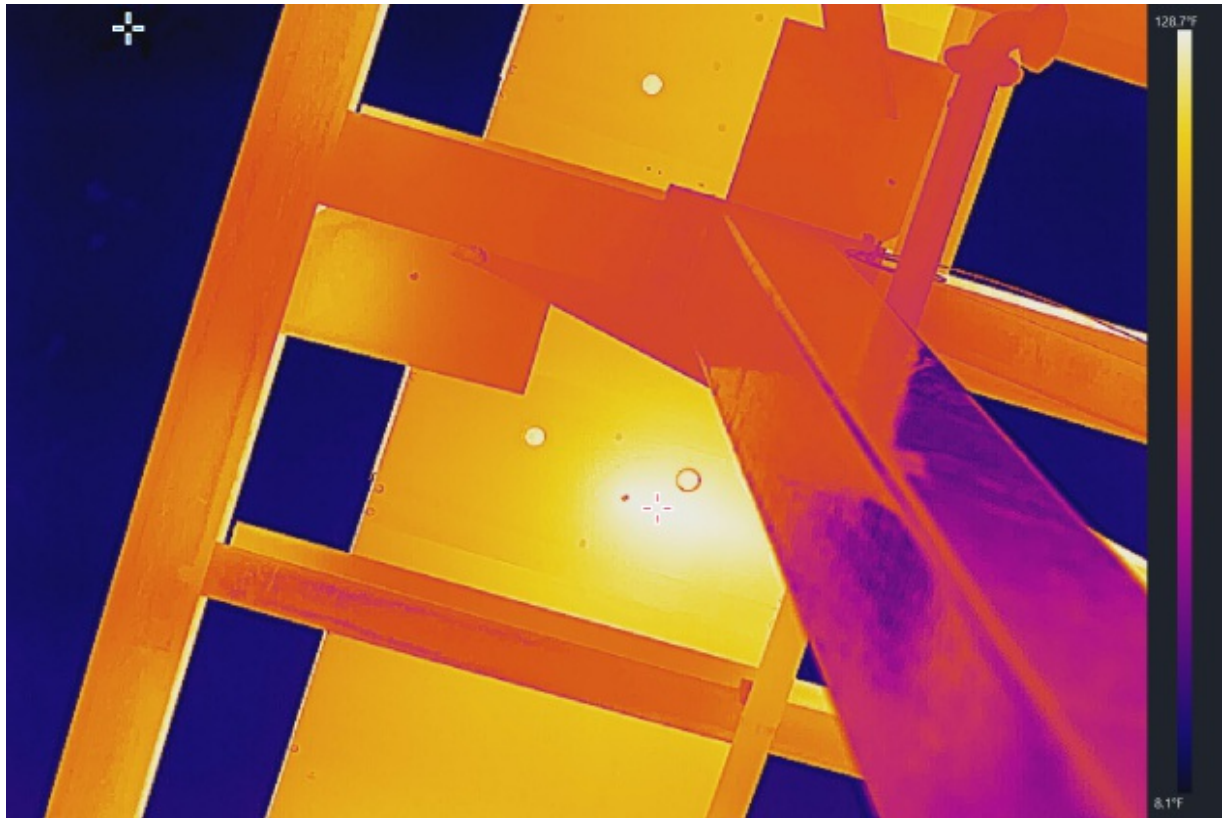

BUS DUCT HEATERS

Measurements		Image Parameters	
Image:Max. Temp.	128.7°F	Distance	1.5m
Image:Min. Temp.	8.1°F	Humidity	60%
		Emissivity	0.97
		Reflected Temp.	77.0°F
		Atmospheric Temp.	91.6°F
Measurement Parameters		Device Information	
		Device Model	SP60
		Device Serial No.	L26310272
		Captured At	2023-08-04 03:01:47
Text Annotation			

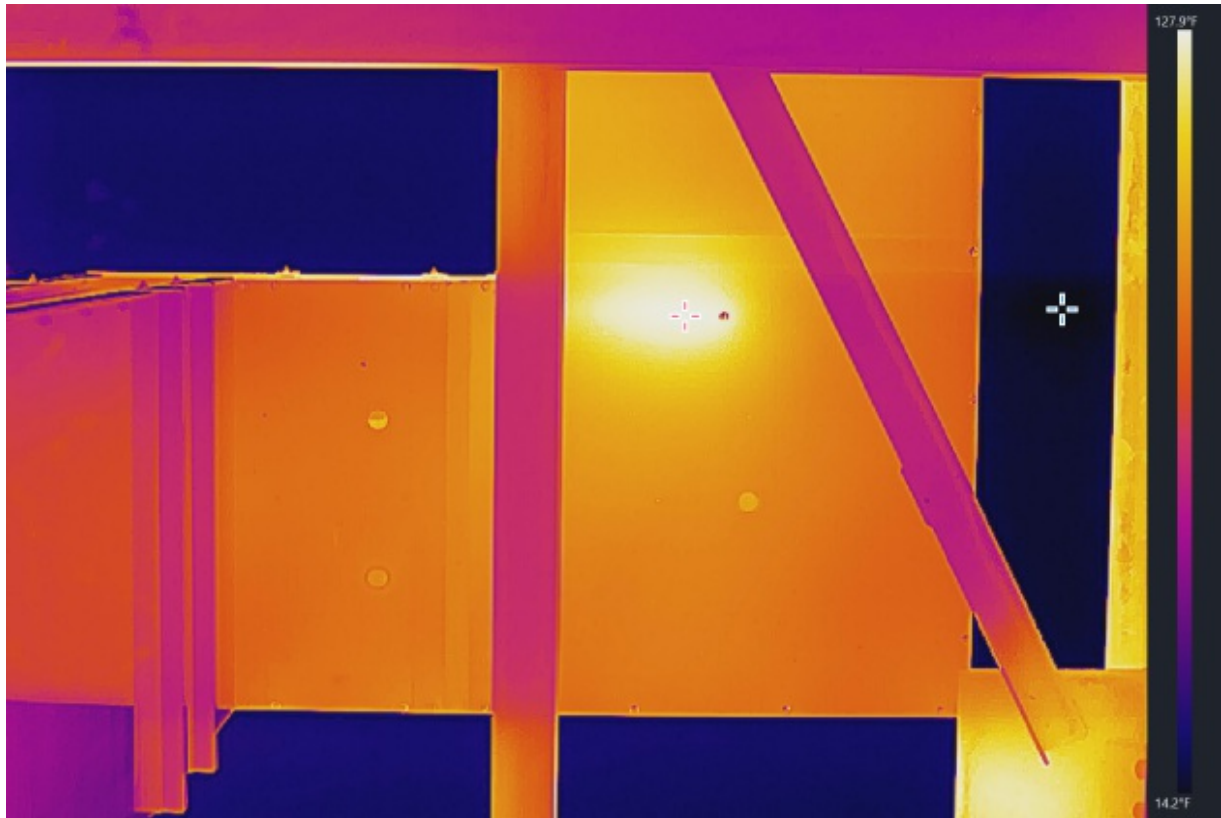

BUS DUCT HEATERS

Measurements		Image Parameters	
Image:Max. Temp.	127.9°F	Distance	1.5m
Image:Min. Temp.	14.2°F	Humidity	60%
		Emissivity	0.97
		Reflected Temp.	77.0°F
		Atmospheric Temp.	91.5°F
Measurement Parameters		Device Information	
		Device Model	SP60
		Device Serial No.	L26310272
		Captured At	2023-08-04 03:01:34
Text Annotation			

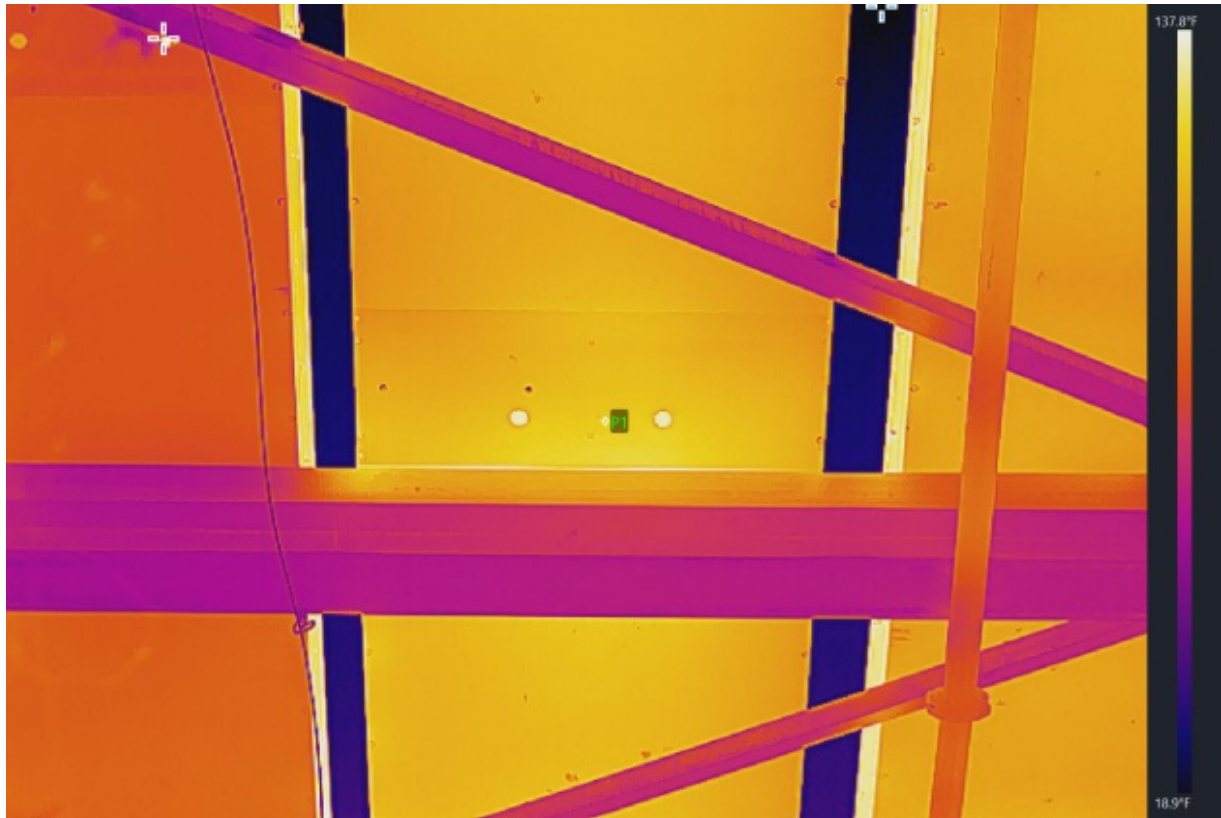

BUS DUCT HEATERS

Measurements		Image Parameters	
Image:Max. Temp.	137.8°F	Distance	1.5m
Image:Min. Temp.	18.9°F	Humidity	60%
P1	117.9°F	Emissivity	0.97
		Reflected Temp.	77.0°F
		Atmospheric Temp.	91.1°F

Measurement Parameters		Device Information	
P1:Emissivity	0.97	Device Model	SP60
P1:Reflected Temp.	77.0°F	Device Serial No.	L26310272
P1:Distance	1.5m	Captured At	2023-08-04 03:01:02

Text Annotation



BUS DUCT HEATERS

Measurements		Image Parameters	
Image:Max. Temp.	133.5°F	Distance	1.5m
Image:Min. Temp.	15.4°F	Humidity	60%
P1	117.1°F	Emissivity	0.97
P2	115.3°F	Reflected Temp.	77.0°F
		Atmospheric Temp.	91.0°F

Measurement Parameters		Device Information	
P1:Emissivity	0.97	Device Model	SP60
P1:Reflected Temp.	77.0°F	Device Serial No.	L26310272
P1:Distance	1.5m	Captured At	2023-08-04 03:00:56
P2:Emissivity	0.97		
P2:Reflected Temp.	77.0°F		
P2:Distance	1.5m		



BUS DUCT HEATERS

Measurements		Image Parameters	
Image:Max. Temp.	136.4°F	Distance	1.5m
Image:Min. Temp.	-0.4°F	Humidity	60%
P1	119.1°F	Emissivity	0.97
P2	116.8°F	Reflected Temp.	77.0°F
		Atmospheric Temp.	90.6°F

Measurement Parameters		Device Information	
P1:Emissivity	0.97	Device Model	SP60
P1:Reflected Temp.	77.0°F	Device Serial No.	L26310272
P1:Distance	1.5m	Captured At	2023-08-04 02:59:59
P2:Emissivity	0.97		
P2:Reflected Temp.	77.0°F		
P2:Distance	1.5m		

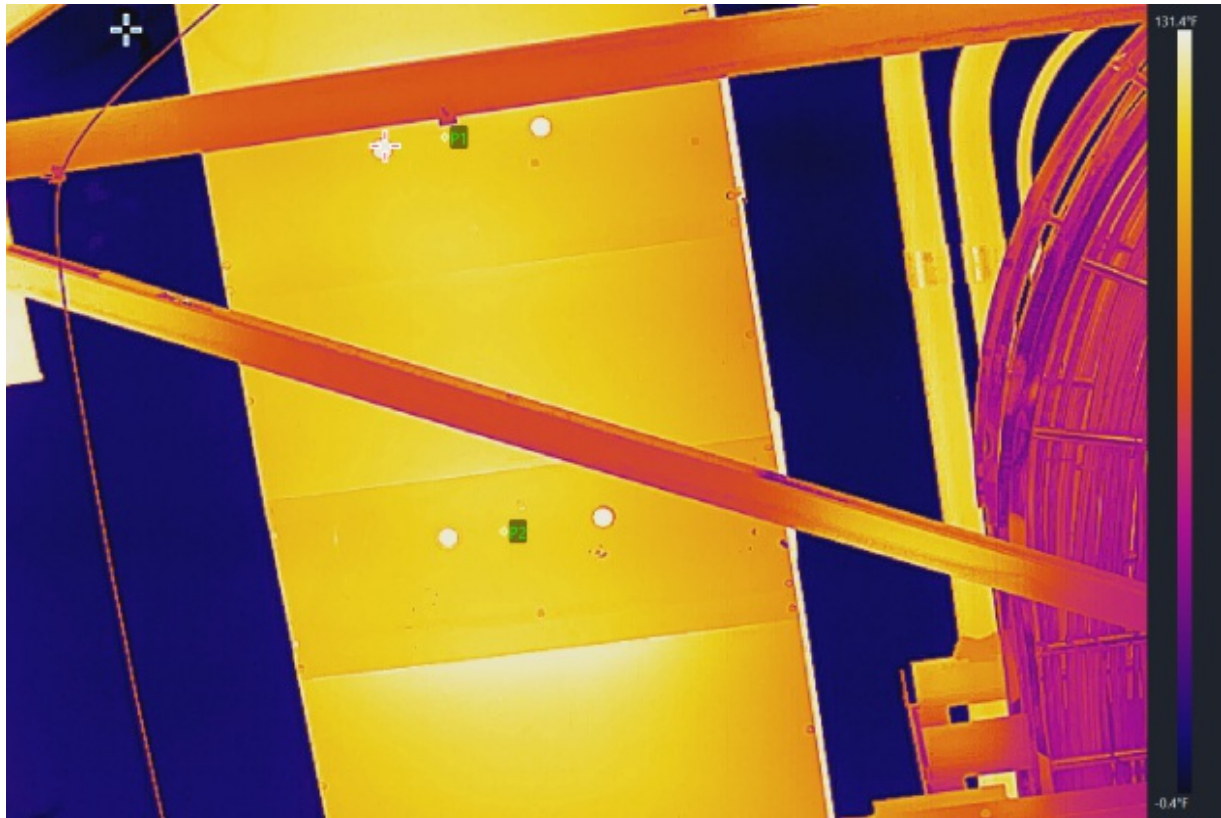

BUS DUCT HEATERS

Measurements		Image Parameters	
Image:Max. Temp.	131.4°F	Distance	1.5m
Image:Min. Temp.	-0.4°F	Humidity	60%
P1	118.8°F	Emissivity	0.97
P2	119.3°F	Reflected Temp.	77.0°F
		Atmospheric Temp.	90.6°F

Measurement Parameters		Device Information	
P1:Emissivity	0.97	Device Model	SP60
P1:Reflected Temp.	77.0°F	Device Serial No.	L26310272
P1:Distance	1.5m	Captured At	2023-08-04 02:59:46
P2:Emissivity	0.97		
P2:Reflected Temp.	77.0°F		
P2:Distance	1.5m		



BUS DUCT HEATERS

Measurements		Image Parameters	
Image:Max. Temp.	133.2°F	Distance	1.5m
Image:Min. Temp.	23.7°F	Humidity	60%
P1	118.6°F	Emissivity	0.97
P2	118.8°F	Reflected Temp.	77.0°F
P3	118.8°F	Atmospheric Temp.	90.5°F

Measurement Parameters		Device Information	
P1:Emissivity	0.97	Device Model	SP60
P1:Reflected Temp.	77.0°F	Device Serial No.	L26310272
P1:Distance	1.5m	Captured At	2023-08-04 02:59:20
P2:Emissivity	0.97		
P2:Reflected Temp.	77.0°F		
P2:Distance	1.5m		
P3:Emissivity	0.97		

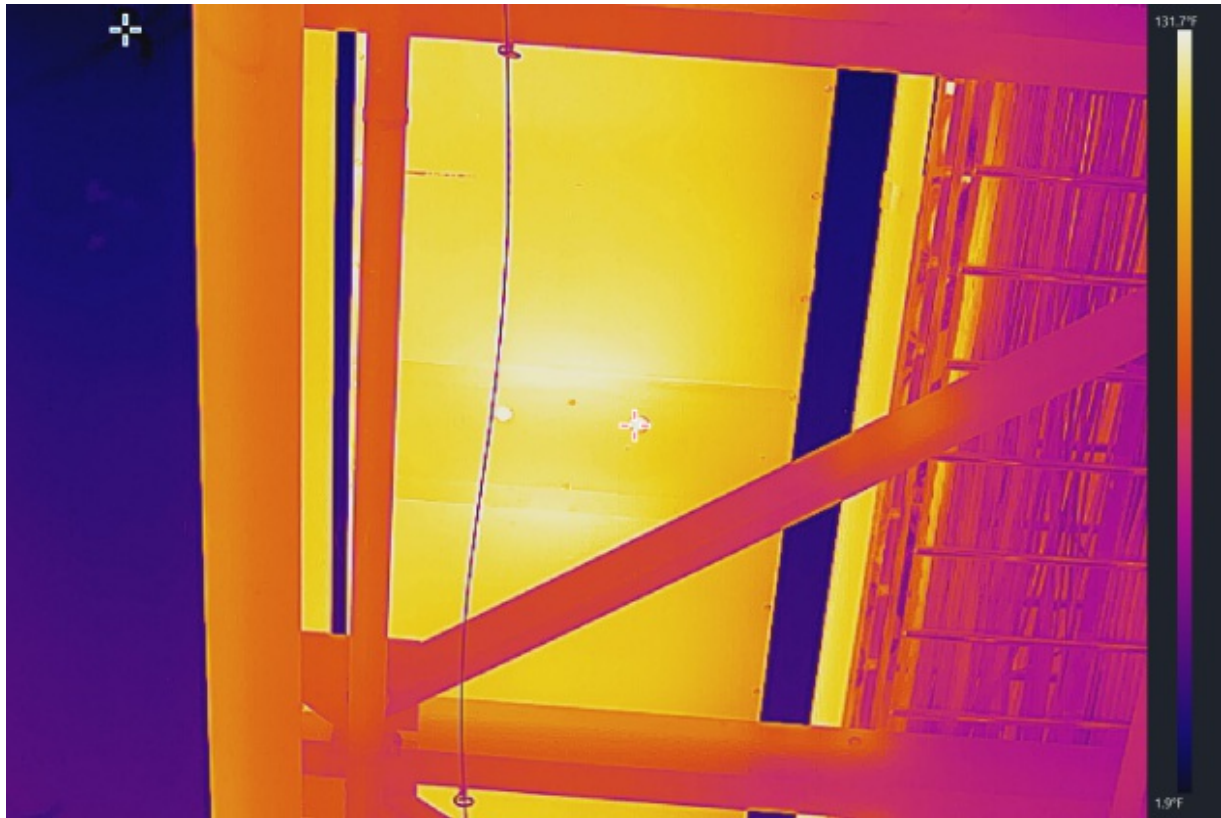

BUS DUCT HEATERS

Measurements		Image Parameters	
Image:Max. Temp.	131.7°F	Distance	1.5m
Image:Min. Temp.	1.9°F	Humidity	60%
		Emissivity	0.97
		Reflected Temp.	77.0°F
		Atmospheric Temp.	90.5°F
Measurement Parameters		Device Information	
		Device Model	SP60
		Device Serial No.	L26310272
		Captured At	2023-08-04 02:59:05
Text Annotation			



BUS DUCT HEATERS

Measurements		Image Parameters	
Image:Max. Temp.	129.0°F	Distance	1.5m
Image:Min. Temp.	-0.0°F	Humidity	60%
		Emissivity	0.97
		Reflected Temp.	77.0°F
		Atmospheric Temp.	90.6°F

Measurement Parameters	Device Information	
	Device Model	SP60
	Device Serial No.	L26310272
	Captured At	2023-08-04 02:58:55

Text Annotation

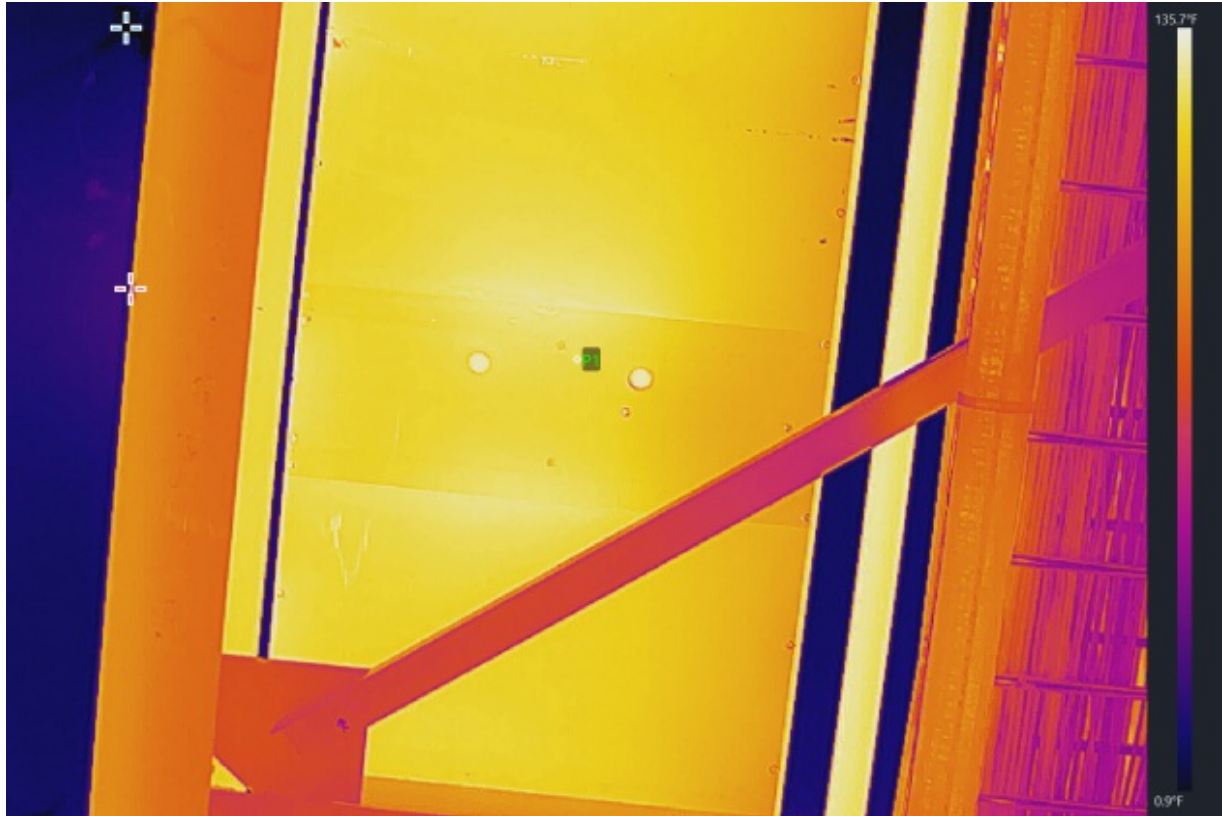

BUS DUCT HEATERS

Measurements		Image Parameters	
Image:Max. Temp.	135.7°F	Distance	1.5m
Image:Min. Temp.	0.9°F	Humidity	60%
P1	118.6°F	Emissivity	0.97
		Reflected Temp.	77.0°F
		Atmospheric Temp.	90.6°F

Measurement Parameters		Device Information	
P1:Emissivity	0.97	Device Model	SP60
P1:Reflected Temp.	77.0°F	Device Serial No.	L26310272
P1:Distance	1.5m	Captured At	2023-08-04 02:58:46

Text Annotation



BUS DUCT HEATERS

Measurements		Image Parameters	
Image:Max. Temp.	124.9°F	Distance	1.5m
Image:Min. Temp.	15.6°F	Humidity	60%
P1	113.5°F	Emissivity	0.97
		Reflected Temp.	77.0°F
		Atmospheric Temp.	90.7°F

Measurement Parameters		Device Information	
P1:Emissivity	0.97	Device Model	SP60
P1:Reflected Temp.	77.0°F	Device Serial No.	L26310272
P1:Distance	1.5m	Captured At	2023-08-04 02:58:36

Text Annotation



BUS DUCT HEATERS

Measurements		Image Parameters	
Image:Max. Temp.	110.8°F	Distance	1.5m
Image:Min. Temp.	30.4°F	Humidity	60%
P1	109.2°F	Emissivity	0.97
P2	106.7°F	Reflected Temp.	77.0°F
		Atmospheric Temp.	91.6°F

Measurement Parameters		Device Information	
P1:Emissivity	0.97	Device Model	SP60
P1:Reflected Temp.	77.0°F	Device Serial No.	L26310272
P1:Distance	1.5m	Captured At	2023-08-04 02:56:22
P2:Emissivity	0.97		
P2:Reflected Temp.	77.0°F		
P2:Distance	1.5m		

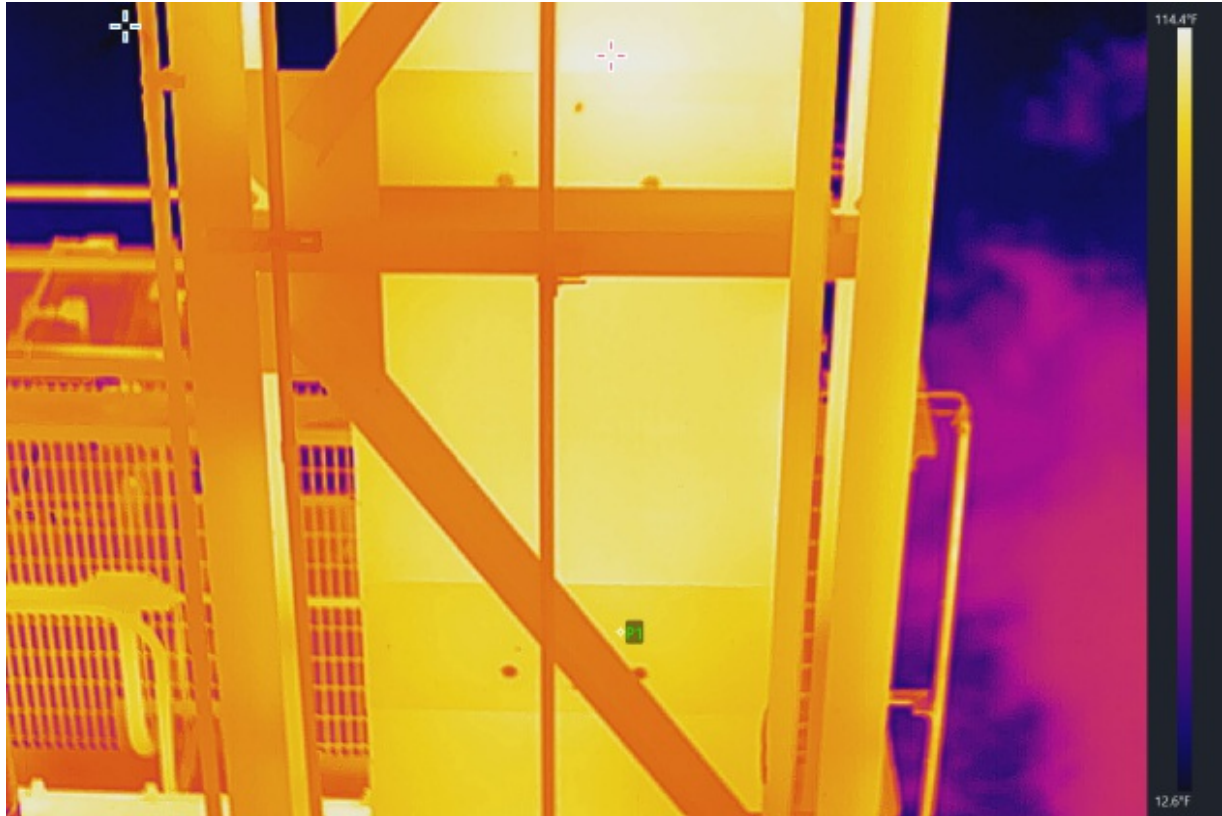

BUS DUCT HEATERS

Measurements		Image Parameters	
Image:Max. Temp.	114.4°F	Distance	1.5m
Image:Min. Temp.	12.6°F	Humidity	60%
P1	108.1°F	Emissivity	0.97
		Reflected Temp.	77.0°F
		Atmospheric Temp.	91.3°F

Measurement Parameters		Device Information	
P1:Emissivity	0.97	Device Model	SP60
P1:Reflected Temp.	77.0°F	Device Serial No.	L26310272
P1:Distance	1.5m	Captured At	2023-08-04 02:56:00

Text Annotation

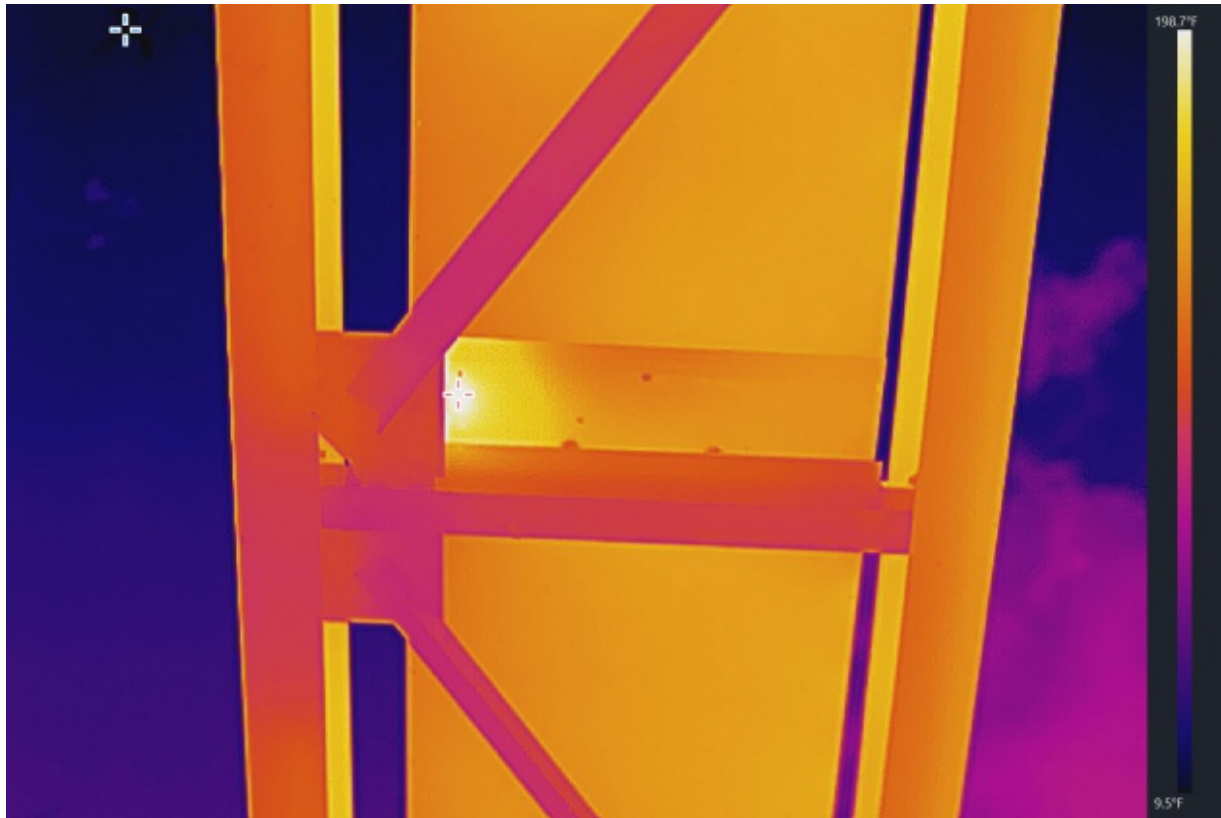

BUS DUCT HEATERS

Measurements		Image Parameters	
Image:Max. Temp.	198.7°F	Distance	1.5m
Image:Min. Temp.	9.5°F	Humidity	60%
		Emissivity	0.97
		Reflected Temp.	77.0°F
		Atmospheric Temp.	91.1°F
Measurement Parameters		Device Information	
		Device Model	SP60
		Device Serial No.	L26310272
		Captured At	2023-08-04 02:55:35
Text Annotation			

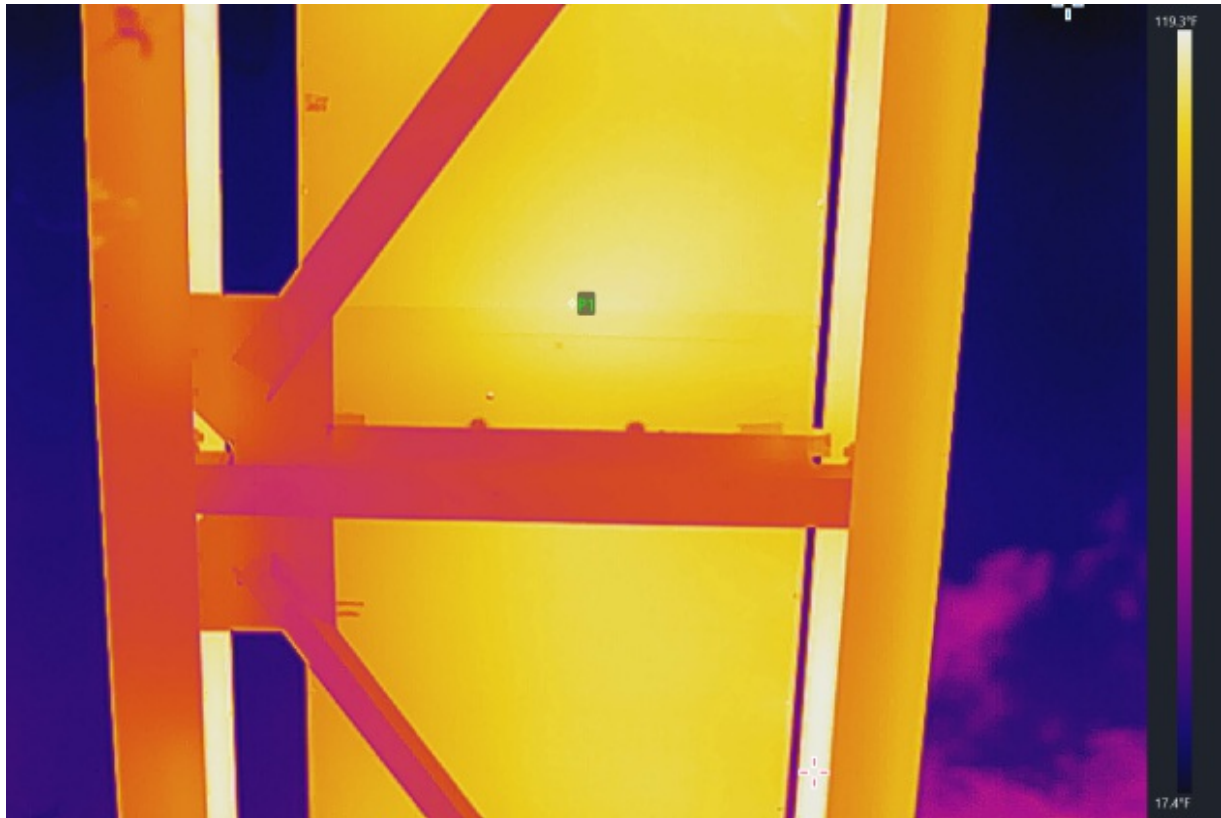

BUS DUCT HEATERS

Measurements		Image Parameters	
Image:Max. Temp.	119.3°F	Distance	1.5m
Image:Min. Temp.	17.4°F	Humidity	60%
P1	117.0°F	Emissivity	0.97
		Reflected Temp.	77.0°F
		Atmospheric Temp.	91.1°F

Measurement Parameters		Device Information	
P1:Emissivity	0.97	Device Model	SP60
P1:Reflected Temp.	77.0°F	Device Serial No.	L26310272
P1:Distance	1.5m	Captured At	2023-08-04 02:55:25

Text Annotation

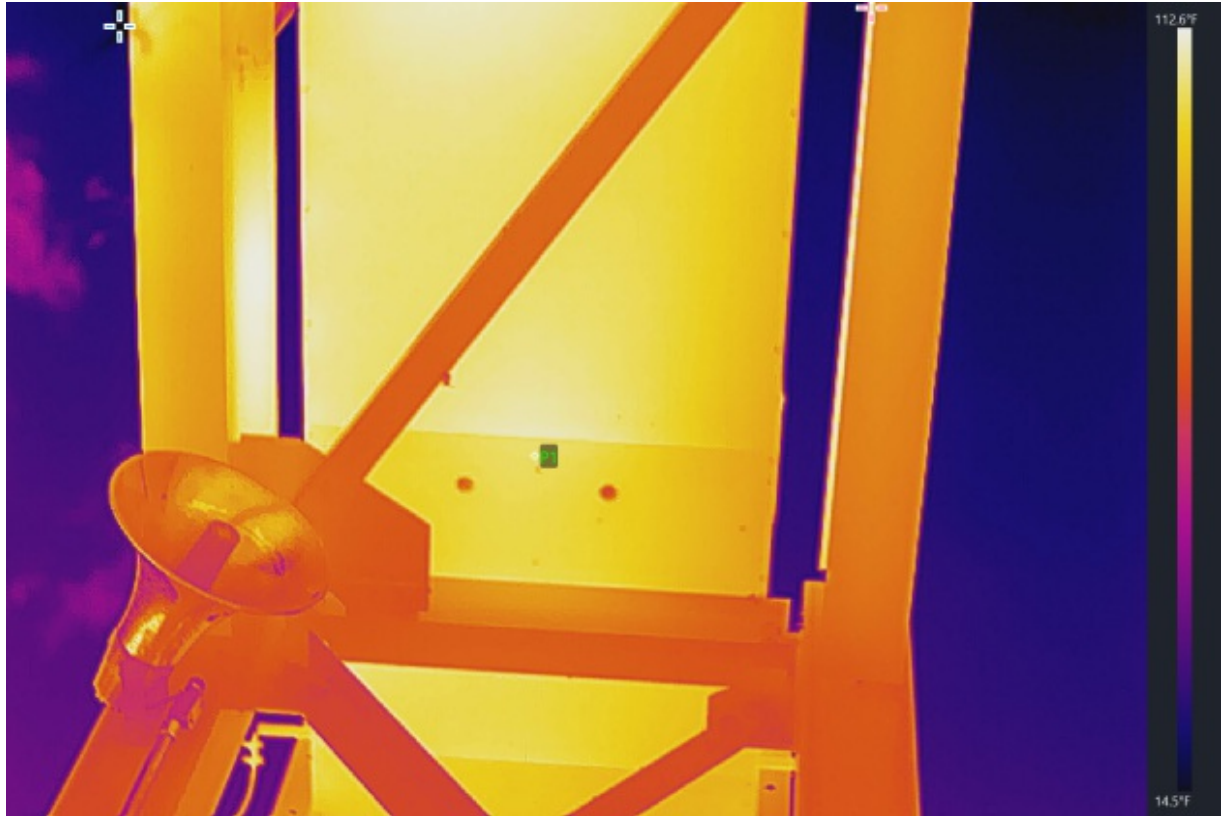

BUS DUCT HEATERS

Measurements		Image Parameters	
Image:Max. Temp.	112.6°F	Distance	1.5m
Image:Min. Temp.	14.5°F	Humidity	60%
P1	109.2°F	Emissivity	0.97
		Reflected Temp.	77.0°F
		Atmospheric Temp.	91.1°F

Measurement Parameters		Device Information	
P1:Emissivity	0.97	Device Model	SP60
P1:Reflected Temp.	77.0°F	Device Serial No.	L26310272
P1:Distance	1.5m	Captured At	2023-08-04 02:55:01

Text Annotation

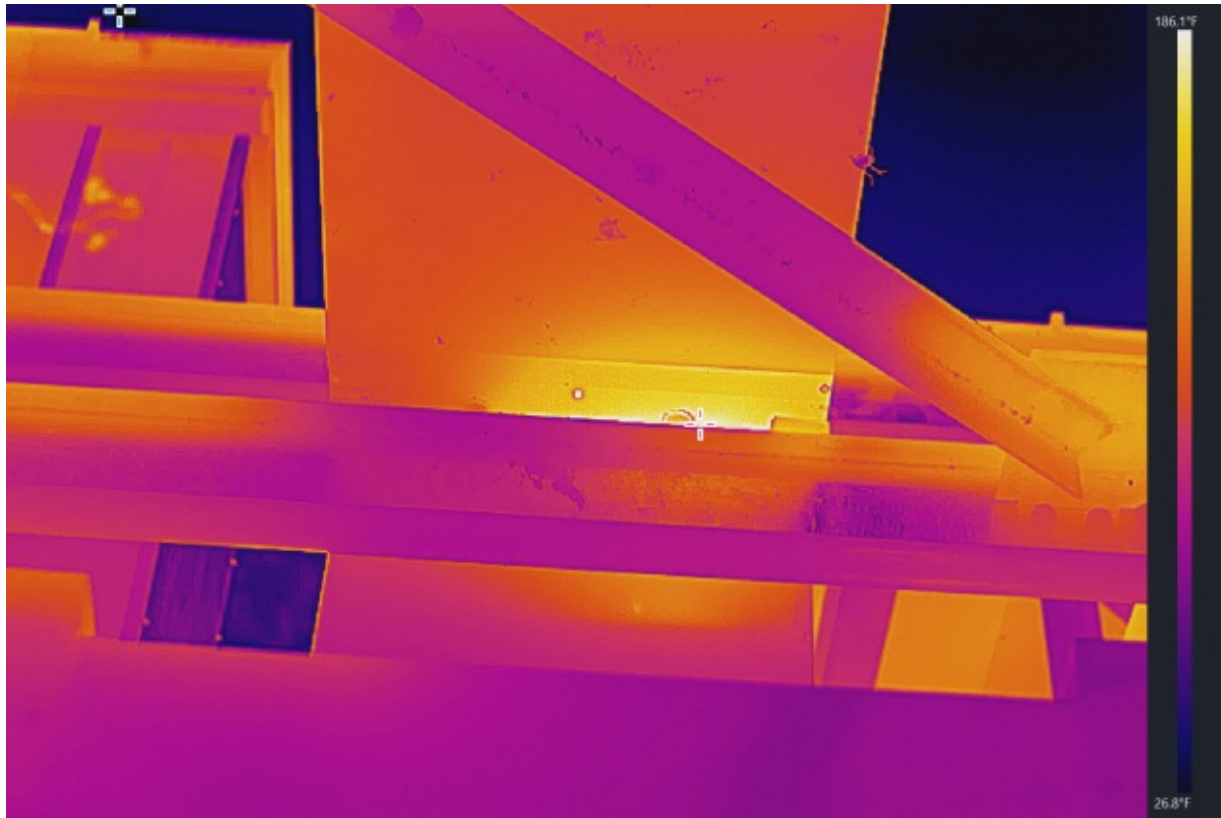

BUS DUCT HEATERS

Measurements		Image Parameters	
Image:Max. Temp.	186.1°F	Distance	1.5m
Image:Min. Temp.	26.8°F	Humidity	60%
		Emissivity	0.97
		Reflected Temp.	77.0°F
		Atmospheric Temp.	91.1°F
Measurement Parameters		Device Information	
		Device Model	SP60
		Device Serial No.	L26310272
		Captured At	2023-08-04 02:53:13
Text Annotation			

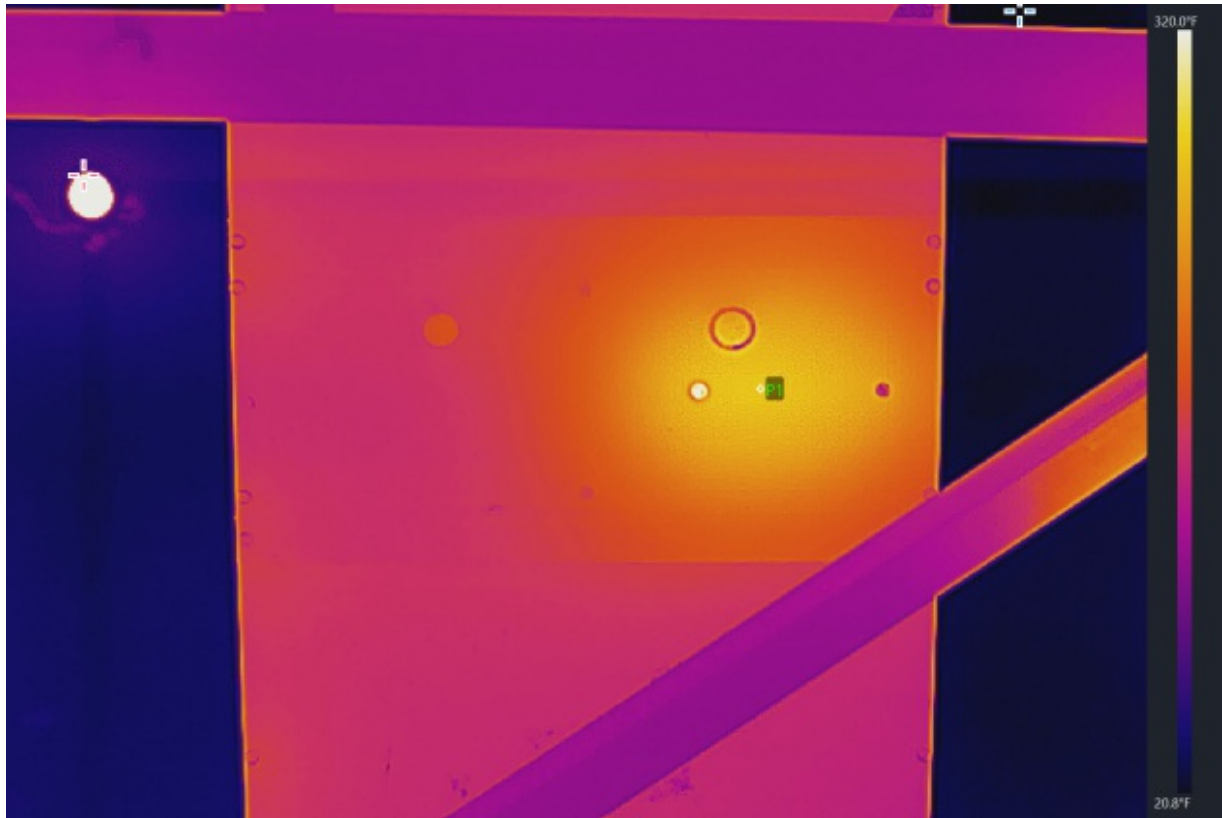

BUS DUCT HEATERS

Measurements		Image Parameters	
Image:Max. Temp.	>320.0°F	Distance	1.5m
Image:Min. Temp.	20.8°F	Humidity	60%
P1	136.6°F	Emissivity	0.97
		Reflected Temp.	77.0°F
		Atmospheric Temp.	91.1°F

Measurement Parameters		Device Information	
P1:Emissivity	0.97	Device Model	SP60
P1:Reflected Temp.	77.0°F	Device Serial No.	L26310272
P1:Distance	1.5m	Captured At	2023-08-04 02:53:04

Text Annotation

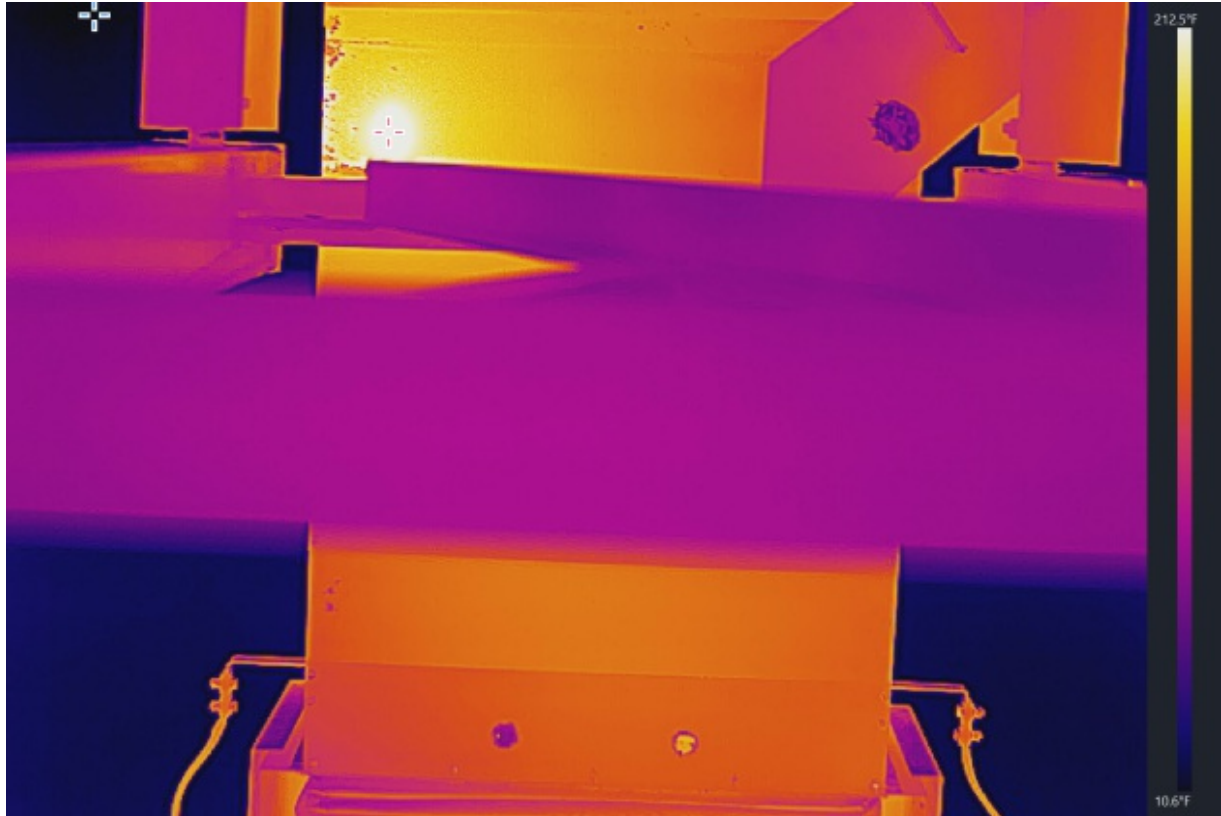

BUS DUCT HEATERS

Measurements		Image Parameters	
Image:Max. Temp.	212.5°F	Distance	1.5m
Image:Min. Temp.	10.6°F	Humidity	60%
		Emissivity	0.97
		Reflected Temp.	77.0°F
		Atmospheric Temp.	91.8°F
Measurement Parameters		Device Information	
		Device Model	SP60
		Device Serial No.	L26310272
		Captured At	2023-08-04 02:52:16
Text Annotation			

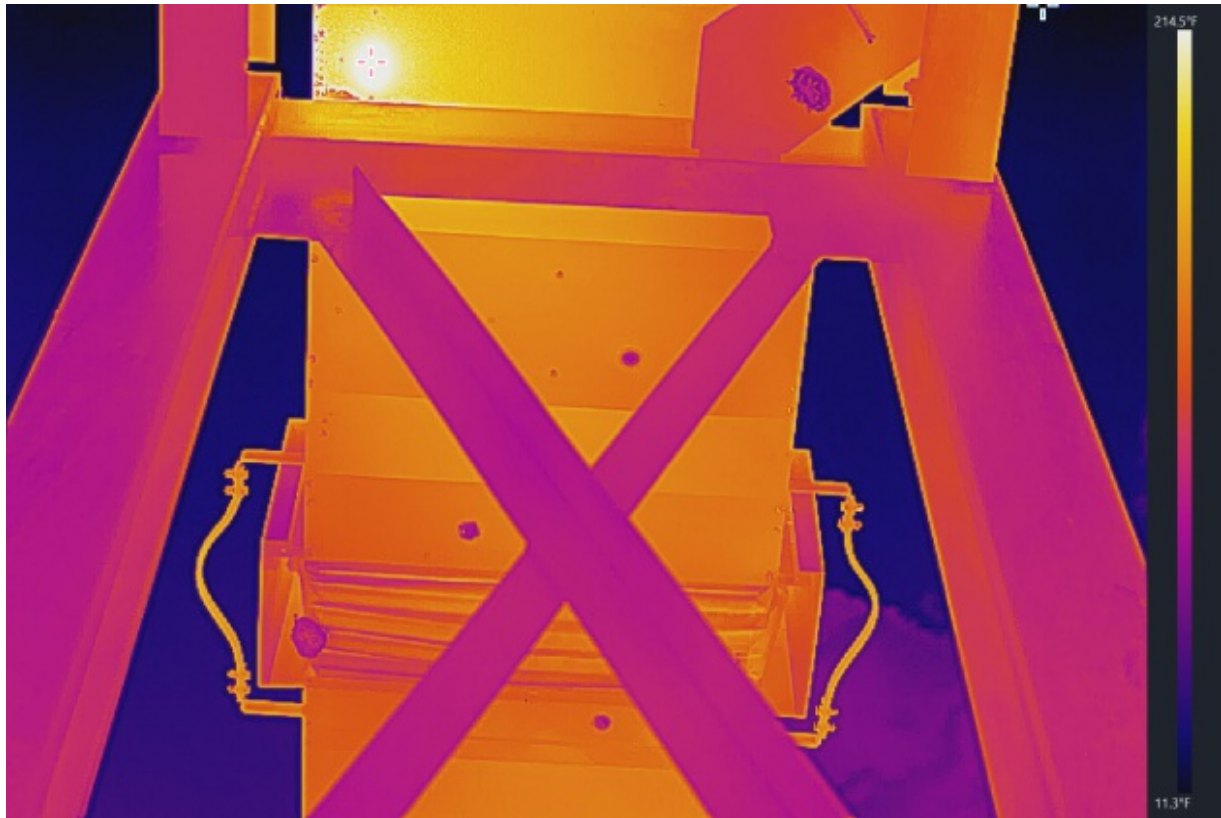

BUS DUCT HEATERS

Measurements		Image Parameters	
Image:Max. Temp.	214.5°F	Distance	1.5m
Image:Min. Temp.	11.3°F	Humidity	60%
		Emissivity	0.97
		Reflected Temp.	77.0°F
		Atmospheric Temp.	92.1°F

Measurement Parameters		Device Information	
		Device Model	SP60
		Device Serial No.	L26310272
		Captured At	2023-08-04 02:52:02

Text Annotation

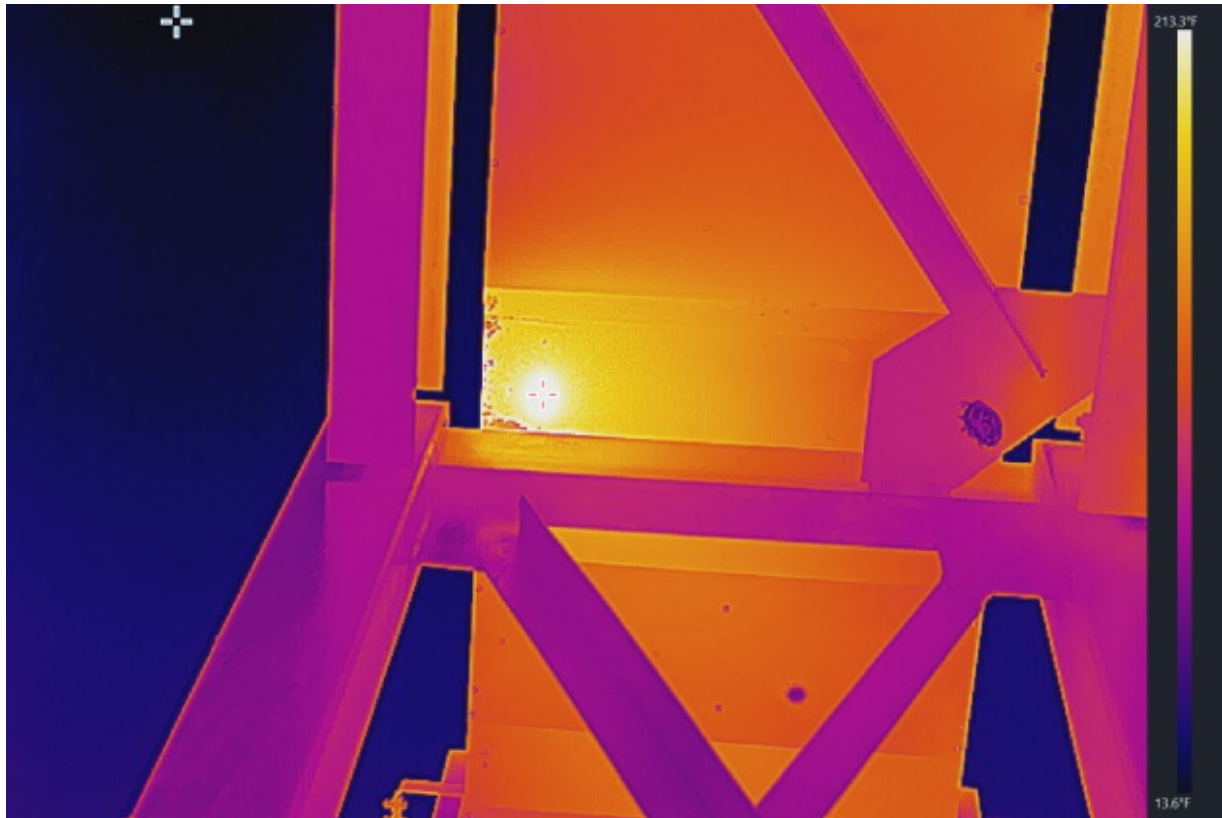

BUS DUCT HEATERS

Measurements		Image Parameters	
Image:Max. Temp.	213.3°F	Distance	1.5m
Image:Min. Temp.	13.6°F	Humidity	60%
		Emissivity	0.97
		Reflected Temp.	77.0°F
		Atmospheric Temp.	92.2°F
Measurement Parameters		Device Information	
		Device Model	SP60
		Device Serial No.	L26310272
		Captured At	2023-08-04 02:51:54
Text Annotation			

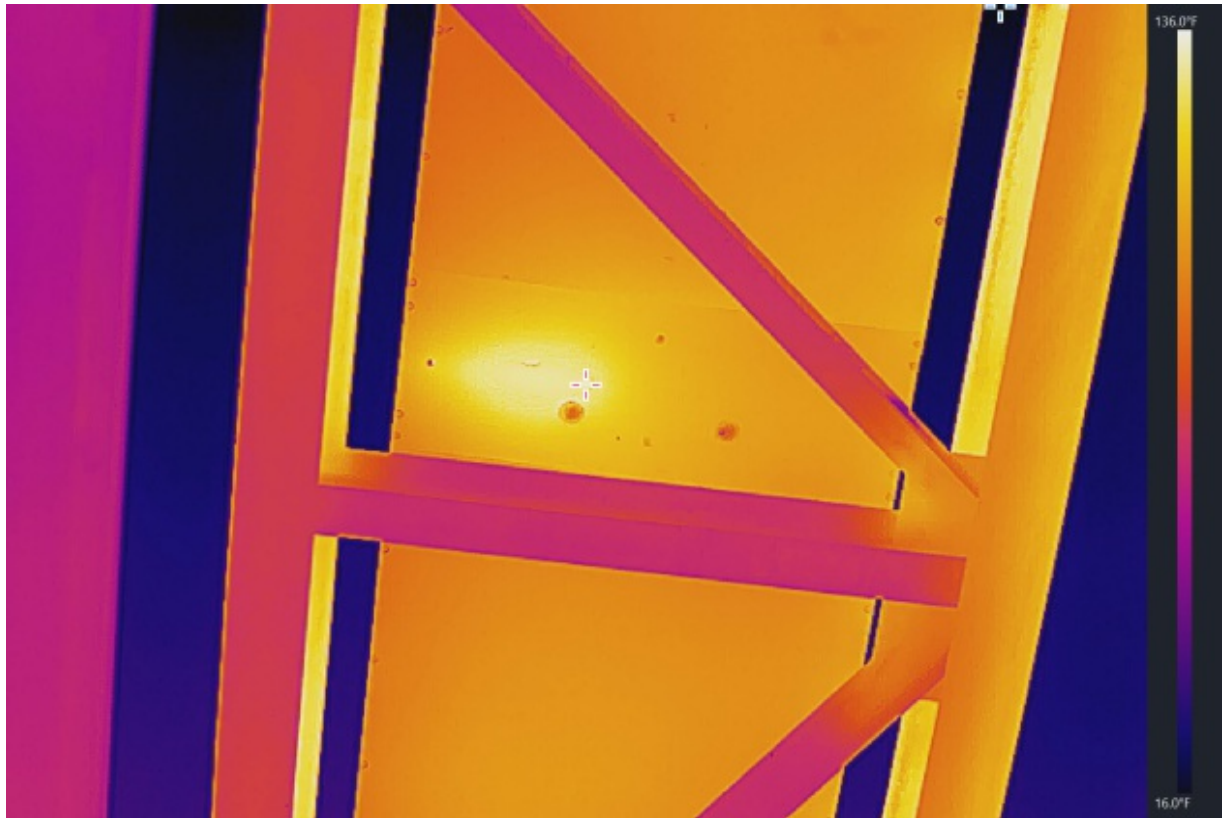

BUS DUCT HEATERS

Measurements		Image Parameters	
Image:Max. Temp.	136.0°F	Distance	1.5m
Image:Min. Temp.	16.0°F	Humidity	60%
		Emissivity	0.97
		Reflected Temp.	77.0°F
		Atmospheric Temp.	92.3°F
Measurement Parameters		Device Information	
		Device Model	SP60
		Device Serial No.	L26310272
		Captured At	2023-08-04 02:51:40
Text Annotation			

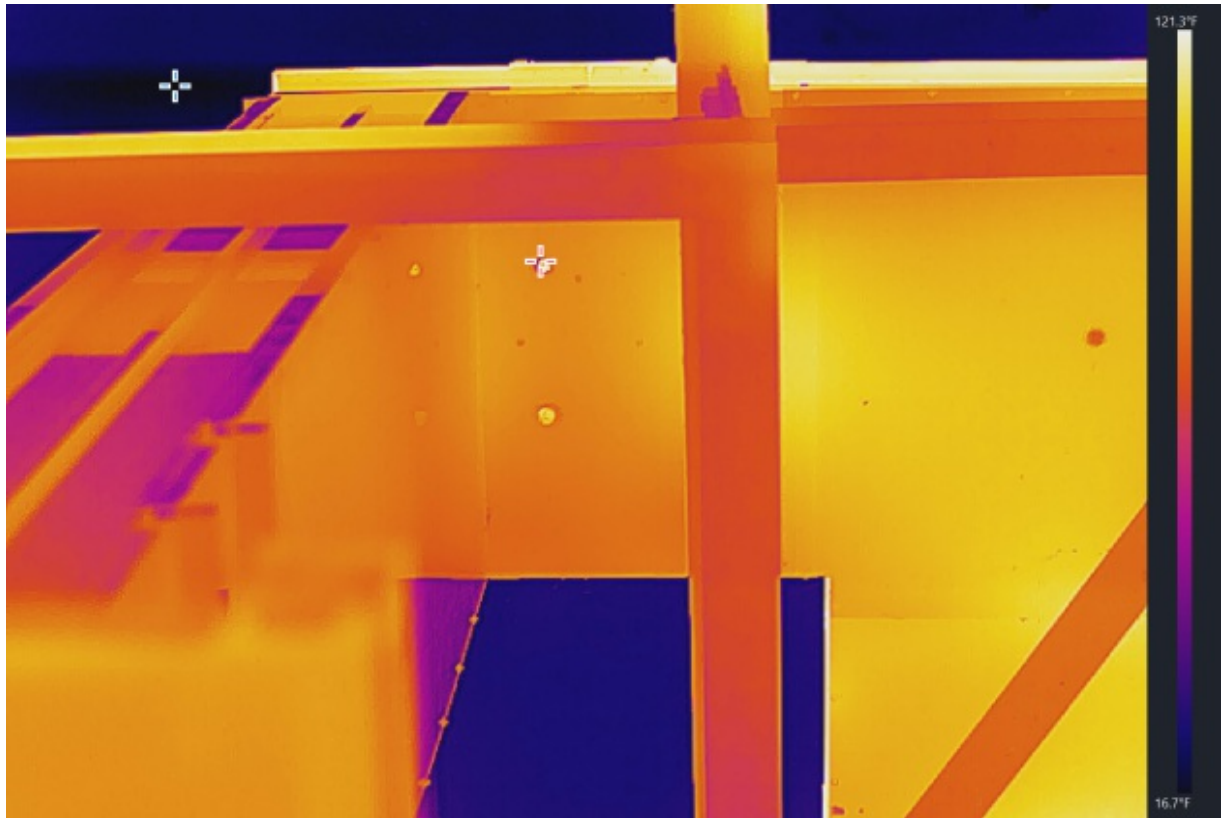

BUS DUCT HEATERS

Measurements		Image Parameters	
Image:Max. Temp.	121.3°F	Distance	1.5m
Image:Min. Temp.	16.7°F	Humidity	60%
		Emissivity	0.97
		Reflected Temp.	77.0°F
		Atmospheric Temp.	92.2°F
Measurement Parameters		Device Information	
		Device Model	SP60
		Device Serial No.	L26310272
		Captured At	2023-08-04 02:51:08
Text Annotation			

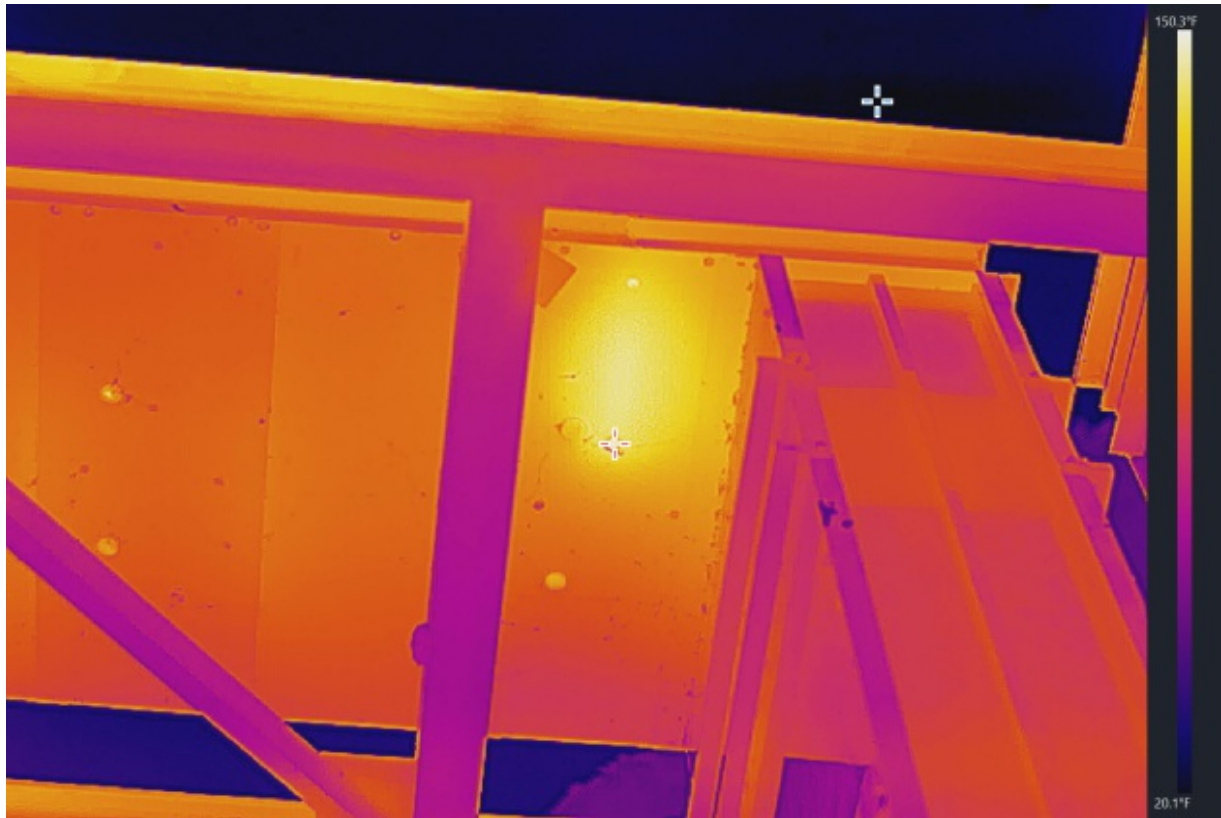

BUS DUCT HEATERS

Measurements		Image Parameters	
Image:Max. Temp.	150.3°F	Distance	1.5m
Image:Min. Temp.	20.1°F	Humidity	60%
		Emissivity	0.97
		Reflected Temp.	77.0°F
		Atmospheric Temp.	91.9°F
Measurement Parameters		Device Information	
		Device Model	SP60
		Device Serial No.	L26310272
		Captured At	2023-08-04 02:50:47
Text Annotation			

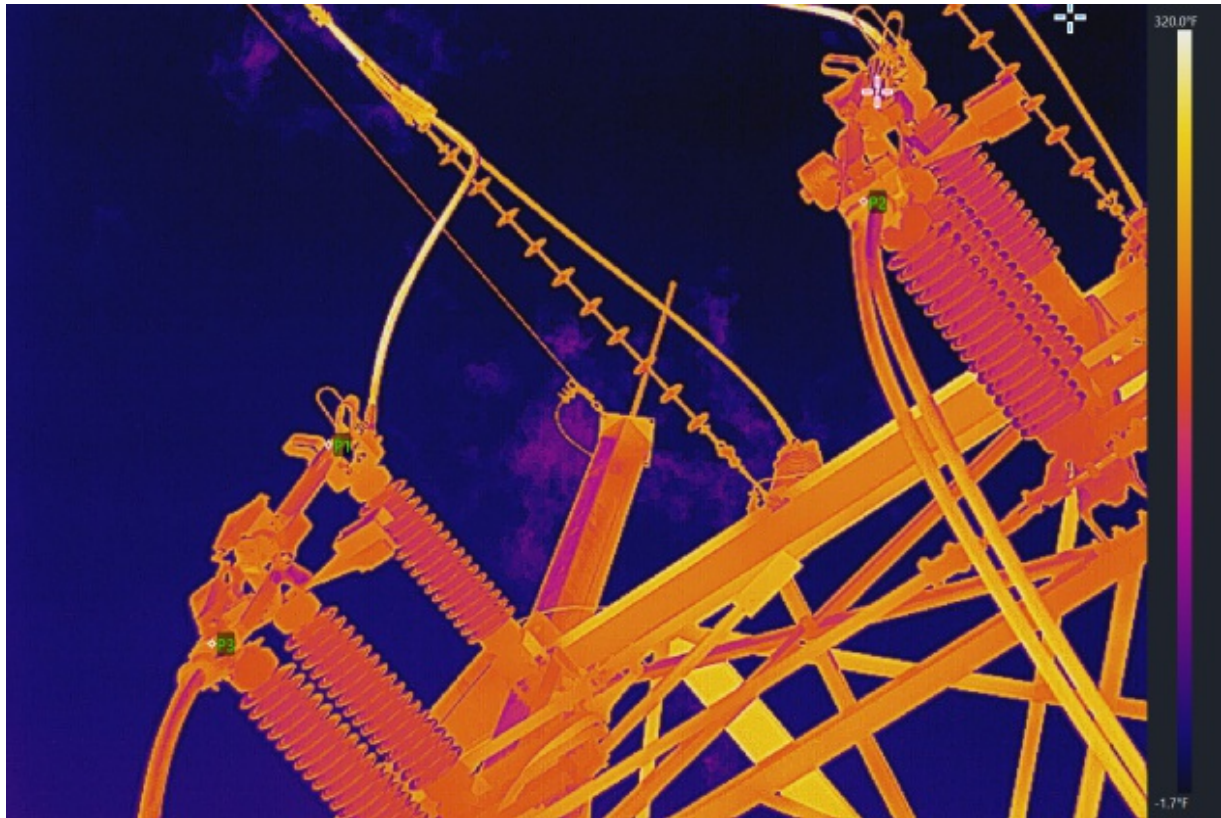

SWITCHYARD MAIN SWITCH

Measurements		Image Parameters	
Image:Max. Temp.	>320.0°F	Distance	1.5m
Image:Min. Temp.	-1.7°F	Humidity	60%
P1	83.8°F	Emissivity	0.97
P2	89.4°F	Reflected Temp.	77.0°F
P3	91.2°F	Atmospheric Temp.	90.2°F

Measurement Parameters		Device Information	
P1:Emissivity	0.97	Device Model	SP60
P1:Reflected Temp.	77.0°F	Device Serial No.	L26310272
P1:Distance	1.5m	Captured At	2023-08-04 02:48:43
P2:Emissivity	0.97		
P2:Reflected Temp.	77.0°F		
P2:Distance	1.5m		
P3:Emissivity	0.97		



SWITCHYARD MAIN SWITCH

Measurements		Image Parameters	
Image:Max. Temp.	110.3°F	Distance	1.5m
Image:Min. Temp.	4.1°F	Humidity	60%
P1	102.0°F	Emissivity	0.97
		Reflected Temp.	77.0°F
		Atmospheric Temp.	90.0°F

Measurement Parameters		Device Information	
P1:Emissivity	0.97	Device Model	SP60
P1:Reflected Temp.	77.0°F	Device Serial No.	L26310272
P1:Distance	1.5m	Captured At	2023-08-04 02:48:30

Text Annotation

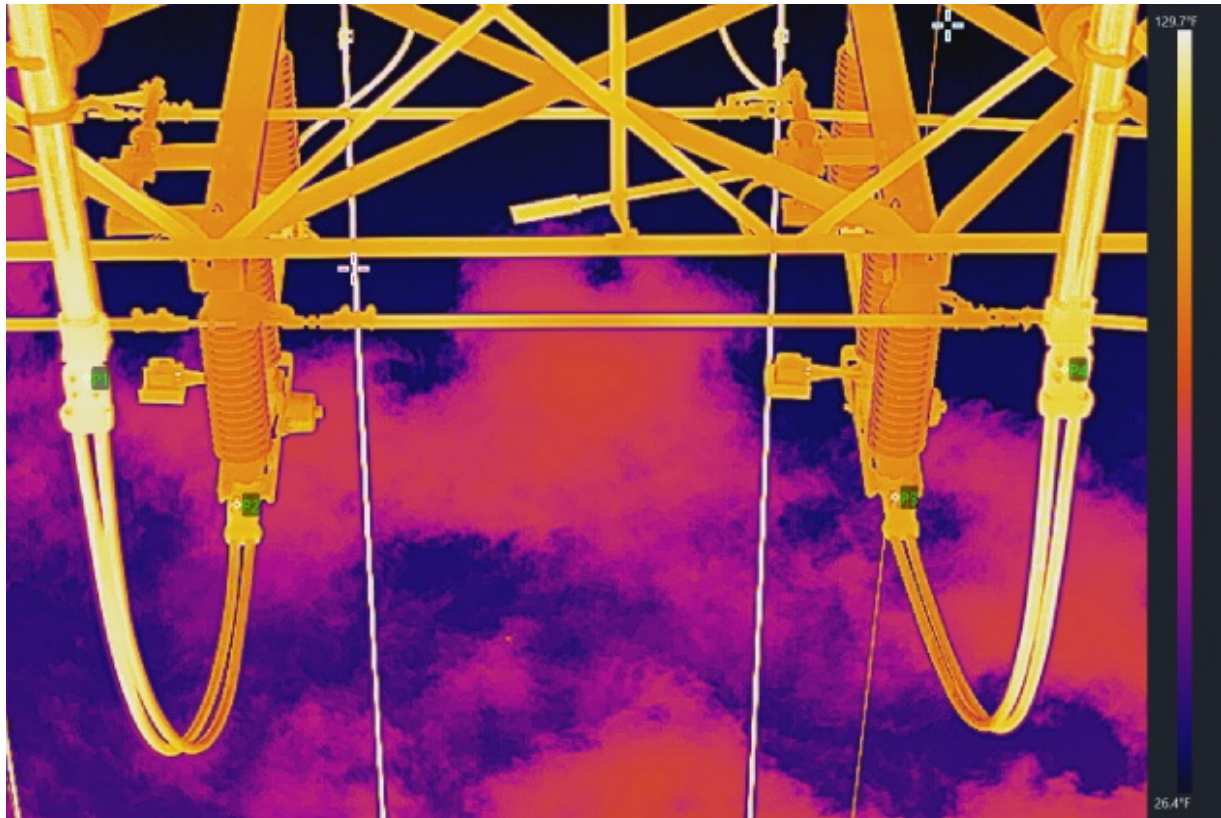

SWITCHYARD MAIN SWITCH

Measurements		Image Parameters	
Image:Max. Temp.	129.7°F	Distance	1.5m
Image:Min. Temp.	26.4°F	Humidity	60%
P1	116.2°F	Emissivity	0.97
P2	102.2°F	Reflected Temp.	77.0°F
P3	97.2°F	Atmospheric Temp.	89.2°F
P4	108.7°F		

Measurement Parameters		Device Information	
P1:Emissivity	0.97	Device Model	SP60
P1:Reflected Temp.	77.0°F	Device Serial No.	L26310272
P1:Distance	1.5m	Captured At	2023-08-04 02:47:36
P2:Emissivity	0.97		
P2:Reflected Temp.	77.0°F		
P2:Distance	1.5m		

P3:Emissivity	0.97
P3:Reflected Temp.	77.0°F
P3:Distance	1.5m
P4:Emissivity	0.97
P4:Reflected Temp.	77.0°F
P4:Distance	1.5m

Text Annotation

Remarks



SWITCHYARD MAIN SWITCH

Measurements		Image Parameters	
Image:Max. Temp.	108.3°F	Distance	1.5m
Image:Min. Temp.	15.8°F	Humidity	60%
P1	101.1°F	Emissivity	0.97
		Reflected Temp.	77.0°F
		Atmospheric Temp.	89.2°F

Measurement Parameters		Device Information	
P1:Emissivity	0.97	Device Model	SP60
P1:Reflected Temp.	77.0°F	Device Serial No.	L26310272
P1:Distance	1.5m	Captured At	2023-08-04 02:46:45

Text Annotation



T2-GSU - HIGH SIDE BUSHINGS

Measurements		Image Parameters	
Image:Max. Temp.	147.4°F	Distance	1.5m
Image:Min. Temp.	39.6°F	Humidity	60%
P1	96.6°F	Emissivity	0.97
P2	96.1°F	Reflected Temp.	77.0°F
		Atmospheric Temp.	89.5°F

Measurement Parameters		Device Information	
P1:Emissivity	0.97	Device Model	SP60
P1:Reflected Temp.	77.0°F	Device Serial No.	L26310272
P1:Distance	1.5m	Captured At	2023-08-04 02:45:55
P2:Emissivity	0.97		
P2:Reflected Temp.	77.0°F		
P2:Distance	1.5m		



T2-GSU - HIGH SIDE BUSHINGS

Measurements		Image Parameters	
Image:Max. Temp.	126.0°F	Distance	1.5m
Image:Min. Temp.	40.1°F	Humidity	60%
P1	112.5°F	Emissivity	0.97
		Reflected Temp.	77.0°F
		Atmospheric Temp.	89.5°F

Measurement Parameters		Device Information	
P1:Emissivity	0.97	Device Model	SP60
P1:Reflected Temp.	77.0°F	Device Serial No.	L26310272
P1:Distance	1.5m	Captured At	2023-08-04 02:45:07

Text Annotation

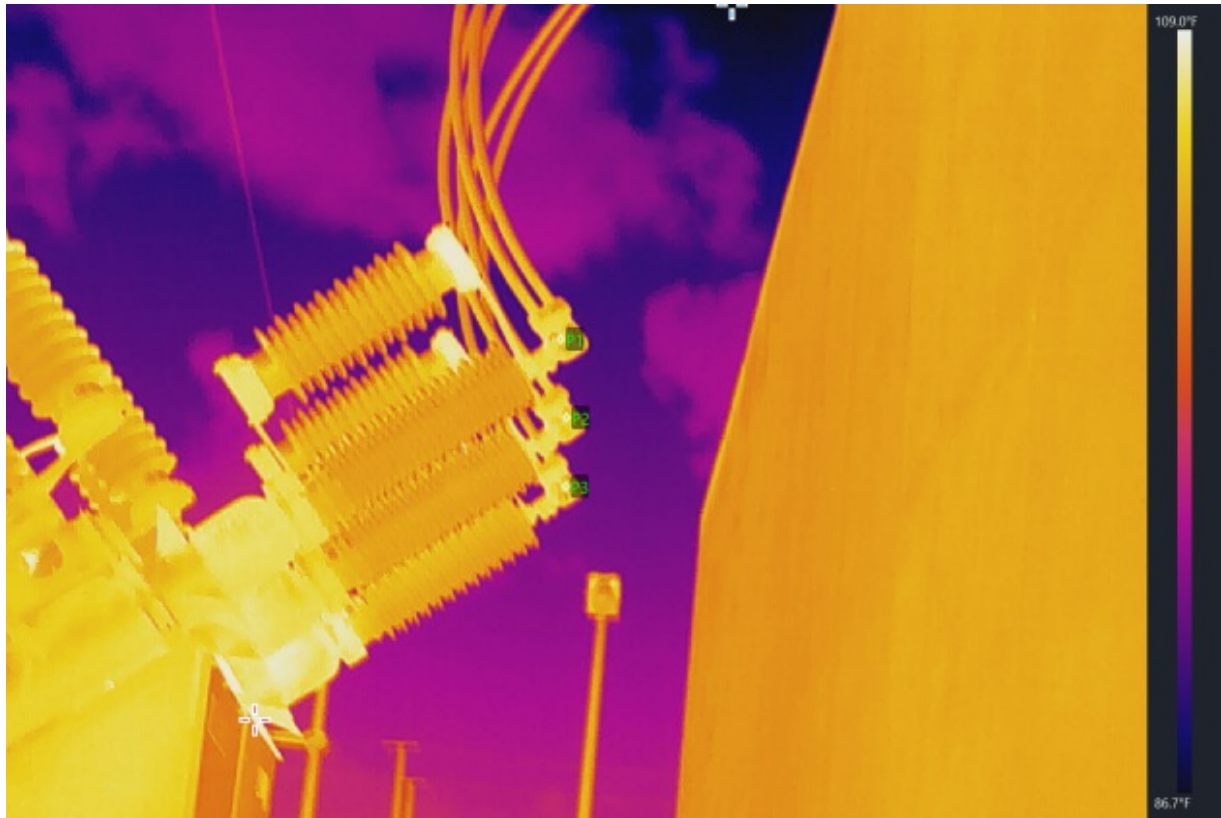

52-L2 - SF6 BREAKER

Measurements		Image Parameters	
Image:Max. Temp.	109.0°F	Distance	1.5m
Image:Min. Temp.	86.7°F	Humidity	60%
P1	104.9°F	Emissivity	0.97
P2	104.7°F	Reflected Temp.	77.0°F
P3	104.7°F	Atmospheric Temp.	88.5°F

Measurement Parameters		Device Information	
P1:Emissivity	0.97	Device Model	SP60
P1:Reflected Temp.	77.0°F	Device Serial No.	L26310272
P1:Distance	1.5m	Captured At	2023-08-04 02:44:07
P2:Emissivity	0.97		
P2:Reflected Temp.	77.0°F		
P2:Distance	1.5m		
P3:Emissivity	0.97		

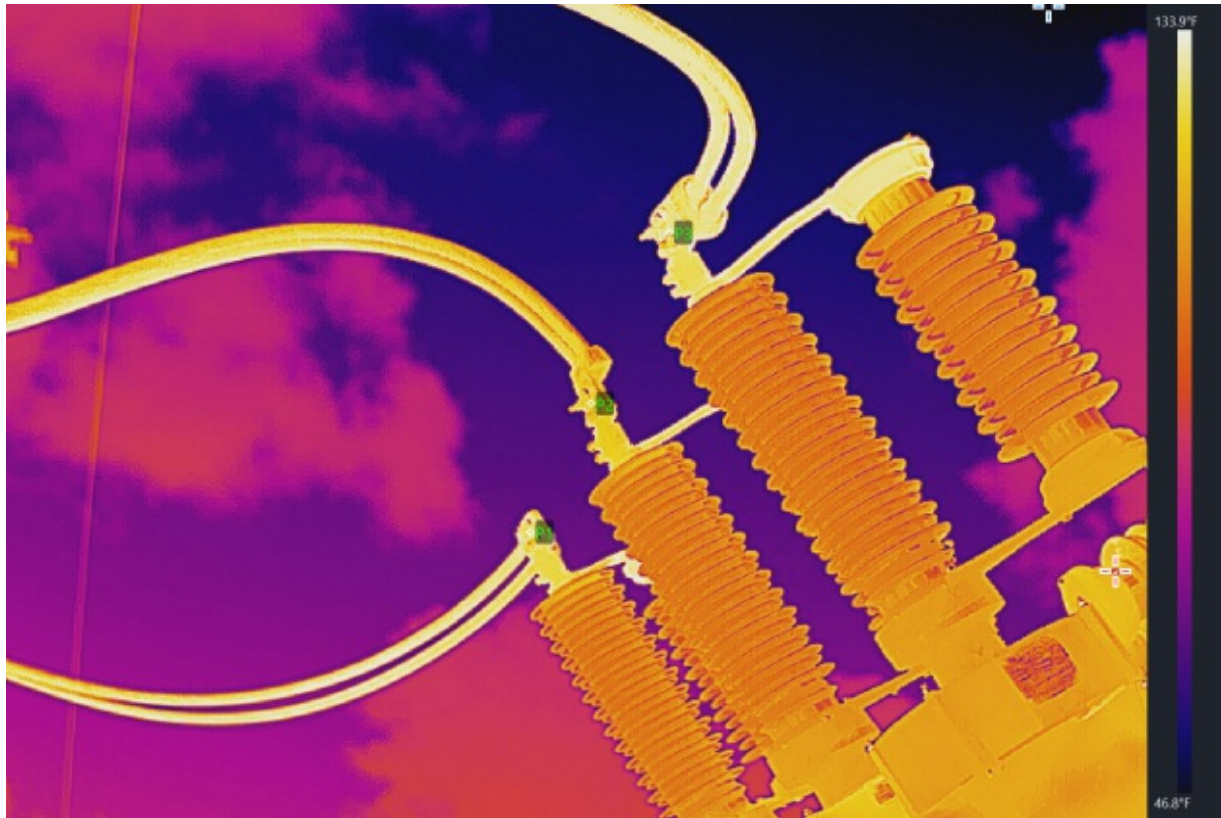

52-L2 - SF6 BREAKER

Measurements		Image Parameters	
Image:Max. Temp.	133.9°F	Distance	1.5m
Image:Min. Temp.	46.8°F	Humidity	60%
P1	113.5°F	Emissivity	0.97
P2	109.6°F	Reflected Temp.	77.0°F
P3	109.0°F	Atmospheric Temp.	86.5°F

Measurement Parameters		Device Information	
P1:Emissivity	0.97	Device Model	SP60
P1:Reflected Temp.	77.0°F	Device Serial No.	L26310272
P1:Distance	1.5m	Captured At	2023-08-04 02:42:45
P2:Emissivity	0.97		
P2:Reflected Temp.	77.0°F		
P2:Distance	1.5m		
P3:Emissivity	0.97		



T2 - MAIN AIR SWITCH

Measurements		Image Parameters	
Image:Max. Temp.	124.3°F	Distance	1.5m
Image:Min. Temp.	53.4°F	Humidity	60%
P1	112.5°F	Emissivity	0.97
P2	110.7°F	Reflected Temp.	77.0°F
P3	114.1°F	Atmospheric Temp.	86.2°F
P4	109.4°F		
P5	113.5°F		

Measurement Parameters		Device Information	
P1:Emissivity	0.97	Device Model	SP60
P1:Reflected Temp.	77.0°F	Device Serial No.	L26310272
P1:Distance	1.5m	Captured At	2023-08-04 02:42:17
P2:Emissivity	0.97		
P2:Reflected Temp.	77.0°F		

P2:Distance	1.5m
P3:Emissivity	0.97
P3:Reflected Temp.	77.0°F
P3:Distance	1.5m
P4:Emissivity	0.97
P4:Reflected Temp.	77.0°F
P4:Distance	1.5m
P5:Emissivity	0.97
P5:Reflected Temp.	77.0°F
P5:Distance	1.5m

Text Annotation

Remarks

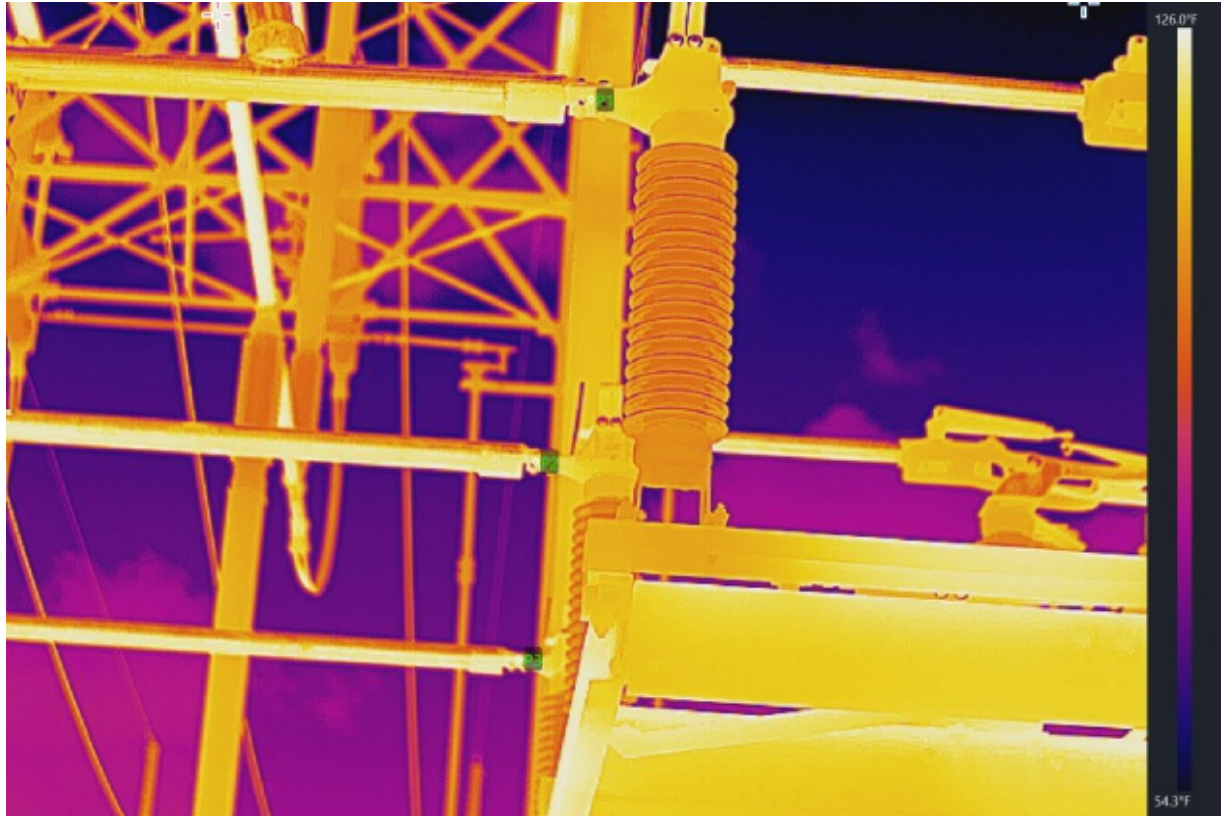

T2 - MAIN AIR SWITCH

Measurements		Image Parameters	
Image:Max. Temp.	126.0°F	Distance	1.5m
Image:Min. Temp.	54.3°F	Humidity	60%
P1	112.5°F	Emissivity	0.97
P2	111.6°F	Reflected Temp.	77.0°F
P3	114.8°F	Atmospheric Temp.	86.3°F

Measurement Parameters		Device Information	
P1:Emissivity	0.97	Device Model	SP60
P1:Reflected Temp.	77.0°F	Device Serial No.	L26310272
P1:Distance	1.5m	Captured At	2023-08-04 02:41:38
P2:Emissivity	0.97		
P2:Reflected Temp.	77.0°F		
P2:Distance	1.5m		
P3:Emissivity	0.97		



T1 - MAIN AIR SWITCH

Measurements		Image Parameters	
Image:Max. Temp.	118.0°F	Distance	1.5m
Image:Min. Temp.	34.0°F	Humidity	60%
P1	105.6°F	Emissivity	0.97
		Reflected Temp.	77.0°F
		Atmospheric Temp.	86.2°F

Measurement Parameters		Device Information	
P1:Emissivity	0.97	Device Model	SP60
P1:Reflected Temp.	77.0°F	Device Serial No.	L26310272
P1:Distance	1.5m	Captured At	2023-08-04 02:40:33

Text Annotation

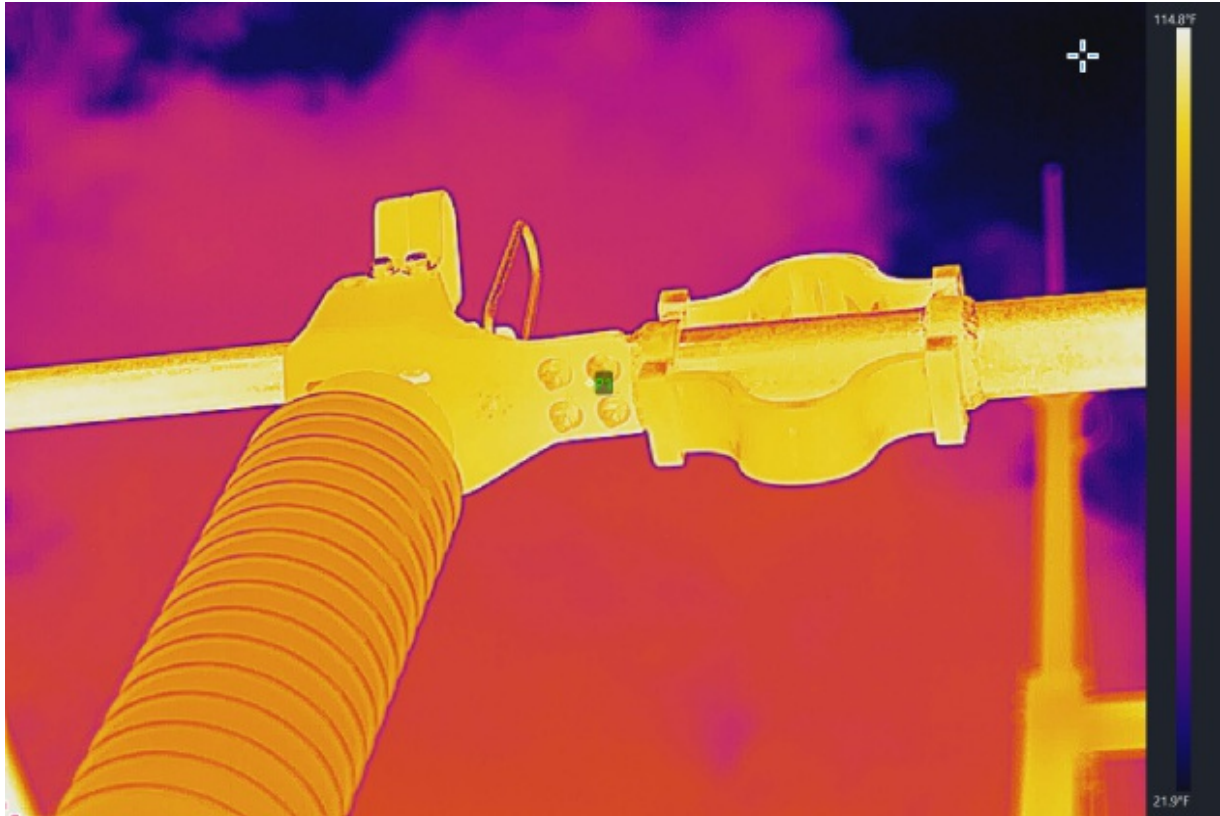

T1 - MAIN AIR SWITCH

Measurements		Image Parameters	
Image:Max. Temp.	114.8°F	Distance	1.5m
Image:Min. Temp.	21.9°F	Humidity	60%
P1	104.2°F	Emissivity	0.97
		Reflected Temp.	77.0°F
		Atmospheric Temp.	86.2°F

Measurement Parameters		Device Information	
P1:Emissivity	0.97	Device Model	SP60
P1:Reflected Temp.	77.0°F	Device Serial No.	L26310272
P1:Distance	1.5m	Captured At	2023-08-04 02:39:45

Text Annotation

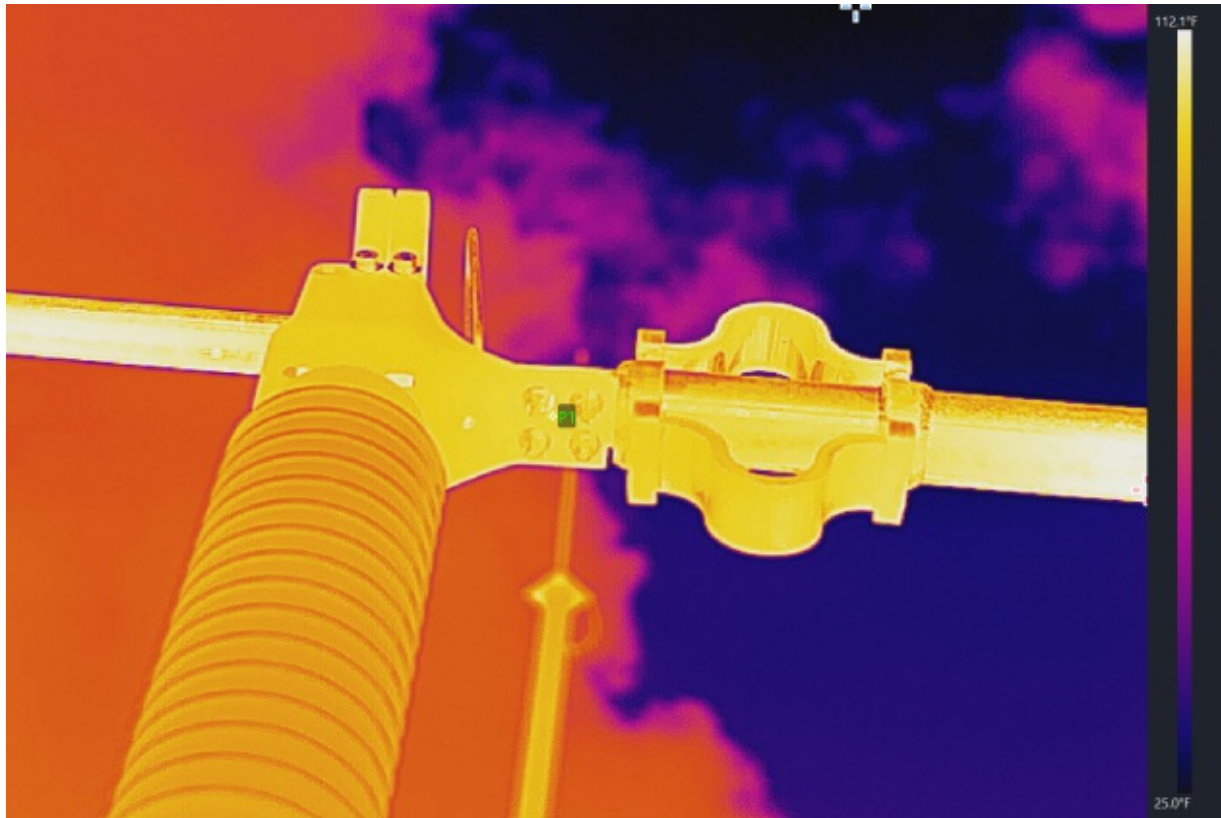

T1 - MAIN AIR SWITCH

Measurements		Image Parameters	
Image:Max. Temp.	112.1°F	Distance	1.5m
Image:Min. Temp.	25.0°F	Humidity	60%
P1	104.5°F	Emissivity	0.97
		Reflected Temp.	77.0°F
		Atmospheric Temp.	86.2°F

Measurement Parameters		Device Information	
P1:Emissivity	0.97	Device Model	SP60
P1:Reflected Temp.	77.0°F	Device Serial No.	L26310272
P1:Distance	1.5m	Captured At	2023-08-04 02:39:14

Text Annotation



T1 - MAIN AIR SWITCH

Measurements		Image Parameters	
Image:Max. Temp.	117.1°F	Distance	1.5m
Image:Min. Temp.	43.9°F	Humidity	60%
P1	106.2°F	Emissivity	0.97
		Reflected Temp.	77.0°F
		Atmospheric Temp.	86.3°F

Measurement Parameters		Device Information	
P1:Emissivity	0.97	Device Model	SP60
P1:Reflected Temp.	77.0°F	Device Serial No.	L26310272
P1:Distance	1.5m	Captured At	2023-08-04 02:38:39

Text Annotation

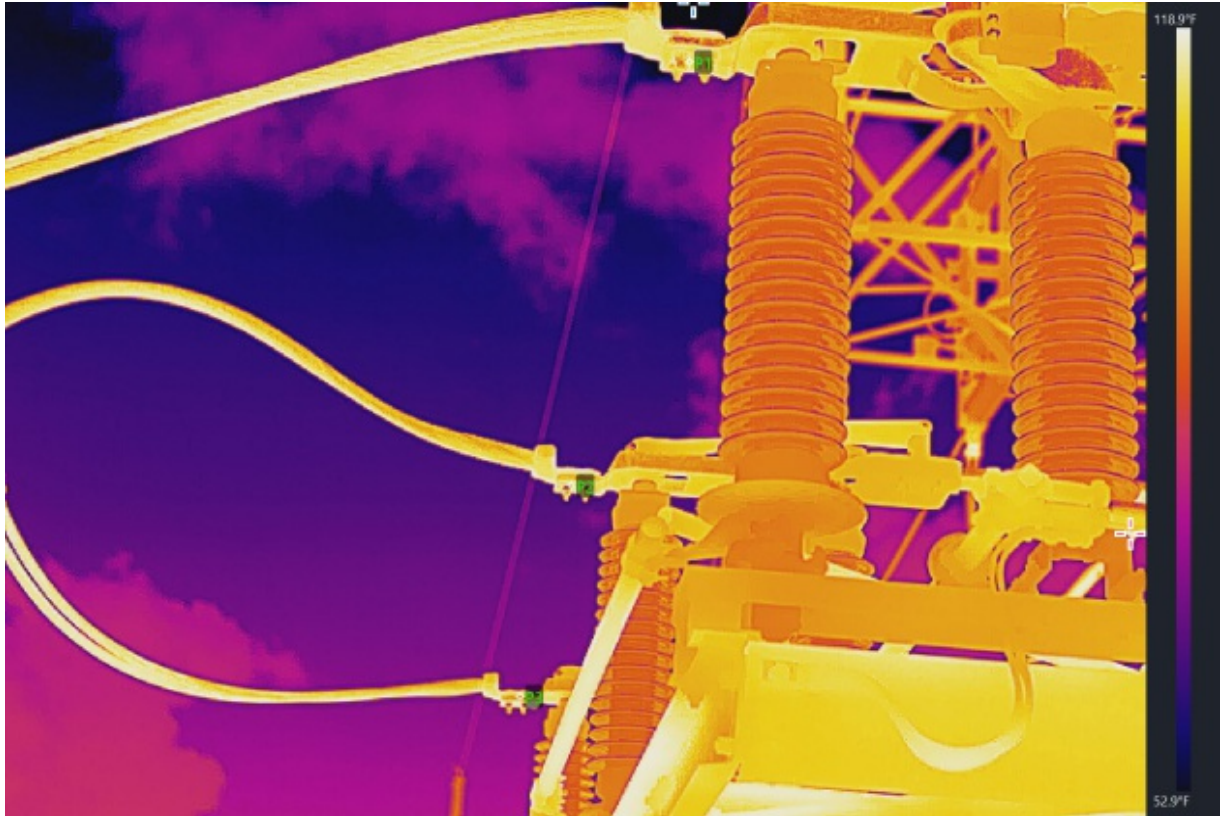

T1 - MAIN AIR SWITCH

Measurements		Image Parameters	
Image:Max. Temp.	118.9°F	Distance	1.5m
Image:Min. Temp.	52.9°F	Humidity	60%
P1	109.9°F	Emissivity	0.97
P2	108.5°F	Reflected Temp.	77.0°F
P3	102.7°F	Atmospheric Temp.	86.3°F

Measurement Parameters		Device Information	
P1:Emissivity	0.97	Device Model	SP60
P1:Reflected Temp.	77.0°F	Device Serial No.	L26310272
P1:Distance	1.5m	Captured At	2023-08-04 02:37:48
P2:Emissivity	0.97		
P2:Reflected Temp.	77.0°F		
P2:Distance	1.5m		
P3:Emissivity	0.97		

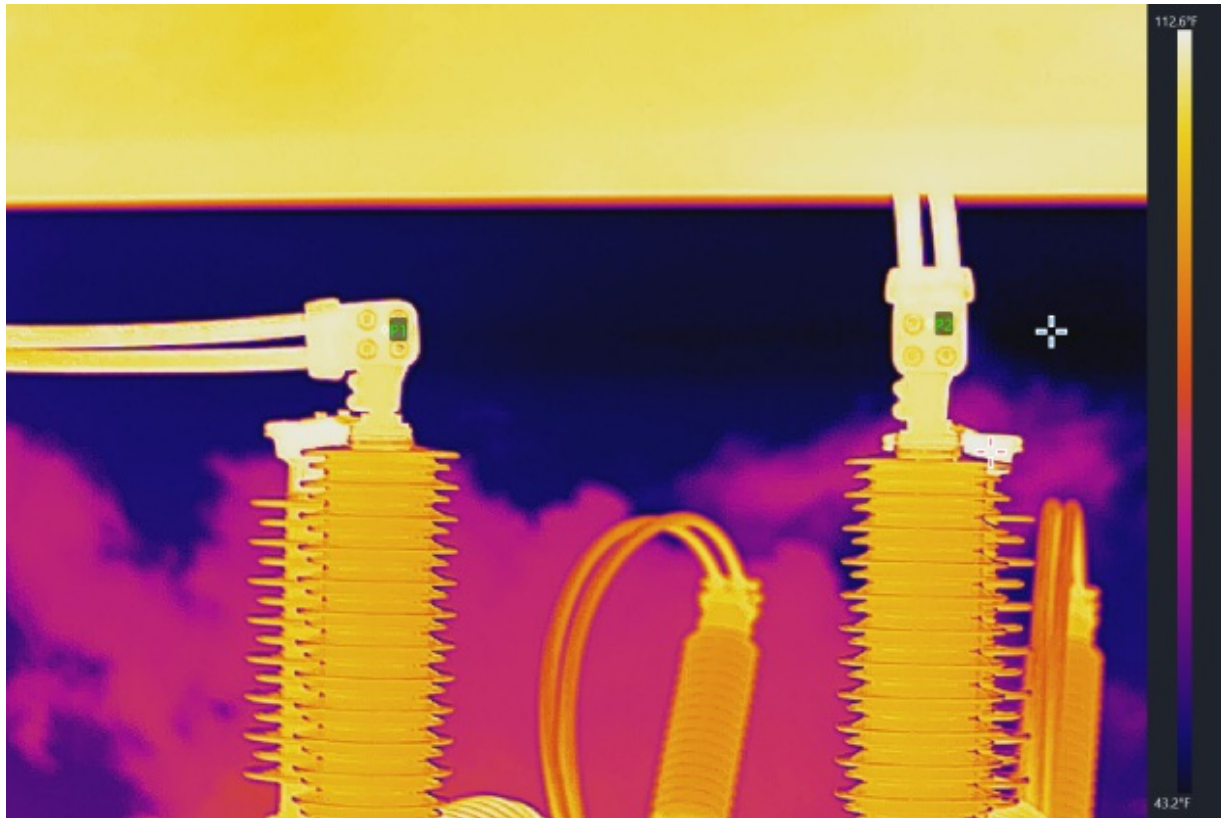

52-L1 - SF6 BREAKER

Measurements		Image Parameters	
Image:Max. Temp.	112.6°F	Distance	1.5m
Image:Min. Temp.	43.2°F	Humidity	60%
P1	109.8°F	Emissivity	0.97
P2	109.8°F	Reflected Temp.	77.0°F
		Atmospheric Temp.	86.3°F

Measurement Parameters		Device Information	
P1:Emissivity	0.97	Device Model	SP60
P1:Reflected Temp.	77.0°F	Device Serial No.	L26310272
P1:Distance	1.5m	Captured At	2023-08-04 02:37:01
P2:Emissivity	0.97		
P2:Reflected Temp.	77.0°F		
P2:Distance	1.5m		

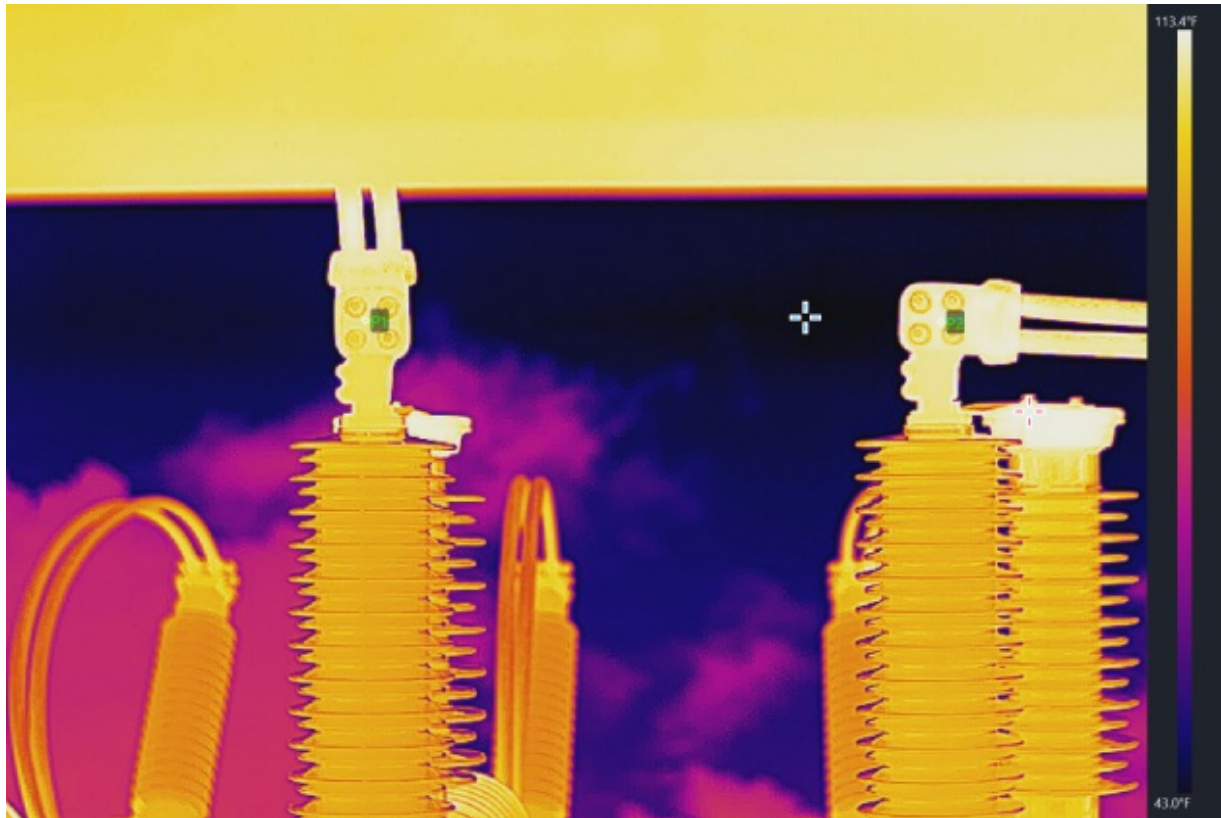

52-L1 - SF6 BREAKER

Measurements		Image Parameters	
Image:Max. Temp.	113.4°F	Distance	1.5m
Image:Min. Temp.	43.0°F	Humidity	60%
P1	109.2°F	Emissivity	0.97
P2	111.7°F	Reflected Temp.	77.0°F
		Atmospheric Temp.	86.3°F

Measurement Parameters		Device Information	
P1:Emissivity	0.97	Device Model	SP60
P1:Reflected Temp.	77.0°F	Device Serial No.	L26310272
P1:Distance	1.5m	Captured At	2023-08-04 02:36:53
P2:Emissivity	0.97		
P2:Reflected Temp.	77.0°F		
P2:Distance	1.5m		

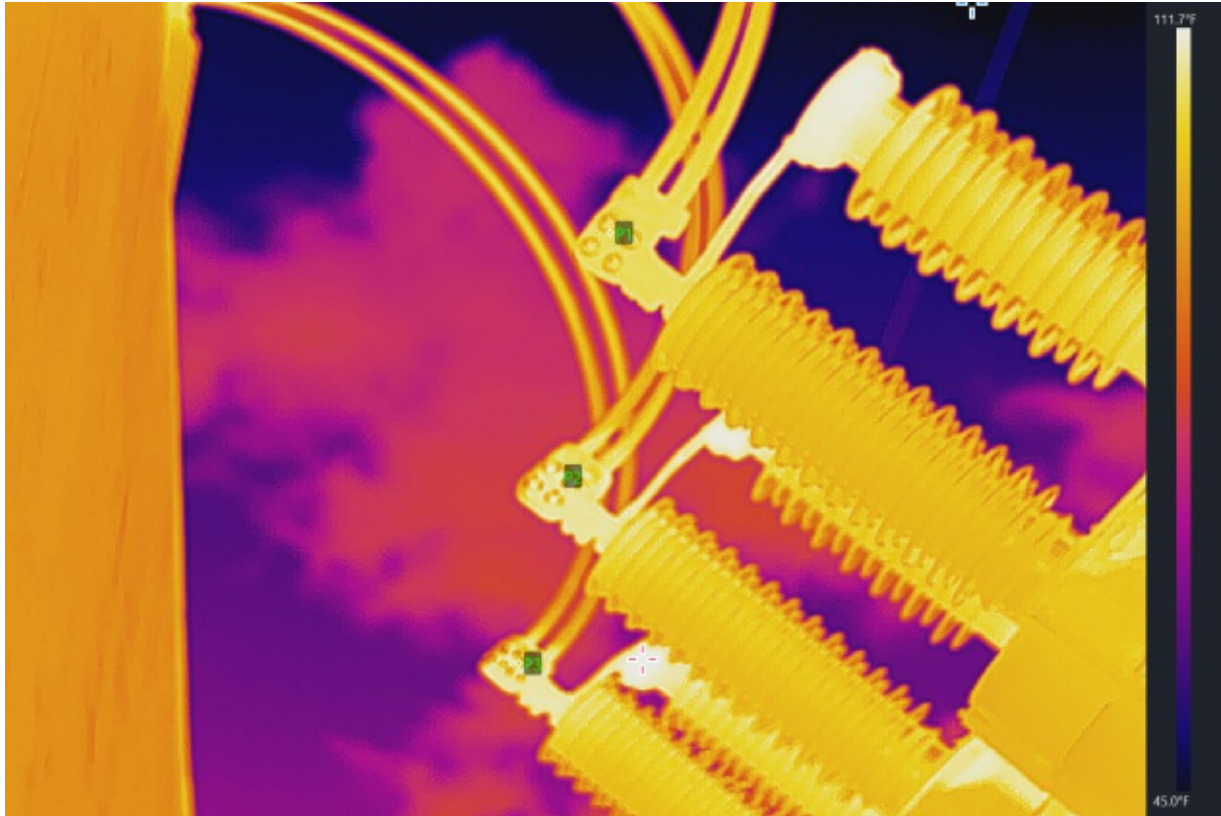

52-L1 - SF6 BREAKER

Measurements		Image Parameters	
Image:Max. Temp.	111.7°F	Distance	1.5m
Image:Min. Temp.	45.0°F	Humidity	60%
P1	102.2°F	Emissivity	0.97
P2	104.5°F	Reflected Temp.	77.0°F
P3	99.5°F	Atmospheric Temp.	86.3°F

Measurement Parameters		Device Information	
P1:Emissivity	0.97	Device Model	SP60
P1:Reflected Temp.	77.0°F	Device Serial No.	L26310272
P1:Distance	1.5m	Captured At	2023-08-04 02:35:09
P2:Emissivity	0.97		
P2:Reflected Temp.	77.0°F		
P2:Distance	1.5m		
P3:Emissivity	0.97		

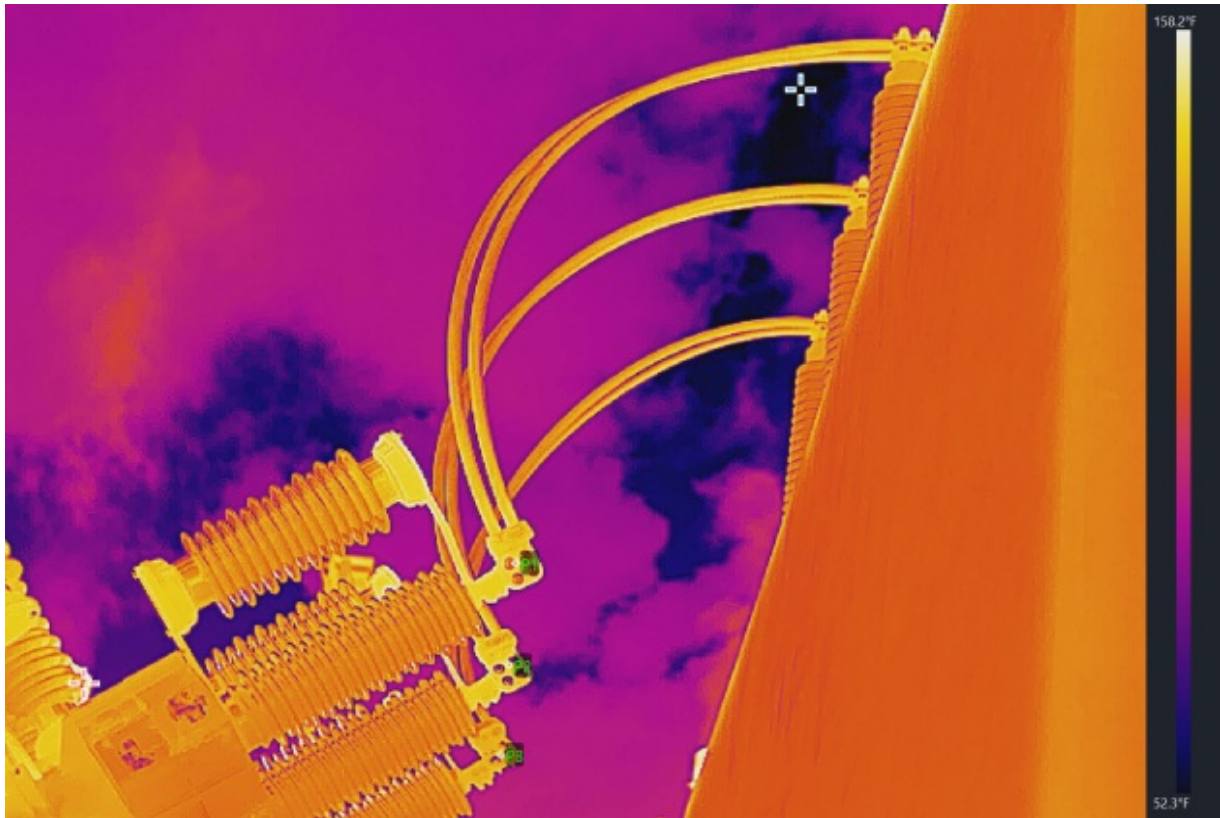

52-L1 - SF6 BREAKER

Measurements		Image Parameters	
Image:Max. Temp.	158.2°F	Distance	1.5m
Image:Min. Temp.	52.3°F	Humidity	60%
P1	104.2°F	Emissivity	0.97
P2	104.2°F	Reflected Temp.	77.0°F
P3	99.7°F	Atmospheric Temp.	86.2°F

Measurement Parameters		Device Information	
P1:Emissivity	0.97	Device Model	SP60
P1:Reflected Temp.	77.0°F	Device Serial No.	L26310272
P1:Distance	1.5m	Captured At	2023-08-04 02:34:46
P2:Emissivity	0.97		
P2:Reflected Temp.	77.0°F		
P2:Distance	1.5m		
P3:Emissivity	0.97		



T1-GSU - HIGH SIDE BUSHINGS

Measurements		Image Parameters	
Image:Max. Temp.	132.3°F	Distance	1.5m
Image:Min. Temp.	50.5°F	Humidity	60%
P1	103.8°F	Emissivity	0.97
P2	115.5°F	Reflected Temp.	77.0°F
		Atmospheric Temp.	86.2°F

Measurement Parameters		Device Information	
P1:Emissivity	0.97	Device Model	SP60
P1:Reflected Temp.	77.0°F	Device Serial No.	L26310272
P1:Distance	1.5m	Captured At	2023-08-04 02:33:55
P2:Emissivity	0.97		
P2:Reflected Temp.	77.0°F		
P2:Distance	1.5m		



T1-GSU - HIGH SIDE BUSHINGS

Measurements		Image Parameters	
Image:Max. Temp.	133.5°F	Distance	1.5m
Image:Min. Temp.	52.9°F	Humidity	60%
P1	103.8°F	Emissivity	0.97
P2	108.7°F	Reflected Temp.	77.0°F
		Atmospheric Temp.	86.3°F

Measurement Parameters		Device Information	
P1:Emissivity	0.97	Device Model	SP60
P1:Reflected Temp.	77.0°F	Device Serial No.	L26310272
P1:Distance	1.5m	Captured At	2023-08-04 02:33:23
P2:Emissivity	0.97		
P2:Reflected Temp.	77.0°F		
P2:Distance	1.5m		



52-L1 - SF6 BREAKER

Measurements		Image Parameters	
Image:Max. Temp.	113.4°F	Distance	1.5m
Image:Min. Temp.	44.6°F	Humidity	60%
P1	105.8°F	Emissivity	0.97
P2	106.9°F	Reflected Temp.	77.0°F
P3	104.4°F	Atmospheric Temp.	86.2°F

Measurement Parameters		Device Information	
P1:Emissivity	0.97	Device Model	SP60
P1:Reflected Temp.	77.0°F	Device Serial No.	L26310272
P1:Distance	1.5m	Captured At	2023-08-04 02:31:53
P2:Emissivity	0.97		
P2:Reflected Temp.	77.0°F		
P2:Distance	1.5m		
P3:Emissivity	0.97		



TOGA® - TEST REPORT

Condition Code: 1
ACCOUNT/LOCATION NUMBERS
80205870

COMPANY NAME CSW Energy		LOCATION Orange Cogeneration Facility			
LOCATION ADDRESS (No., Street, City, State, Zip) 1901 Clear Springs Rd., Bartow FL 33830					
UNIT DESIGNATION 116E100	SERIAL NUMBER MNL-9183	EQUIPMENT TYPE GSU - Unit Transformer	MANUFACTURER ABB	YEAR BUILT 1994	

SAMPLE REPORT ORDER DETAILS

SAMPLED BY Steve Shore		PCB LEVEL (ppm) Unknown		OIL PRESERVATION METHOD Gas Blanketed - Sealed					
COOLING METHOD OA/FA	OIL VOLUME 4,828 GALS	VOLTAGE KV	PRI 14	SEC 69	TER	SIZE MVA	PRI 49	SEC 66	TER
CONDITION CODE 1	SCHEDULED NEXT SAMPLE DATE 03/01/25		SCHEDULED TESTS DGA, Screen, Moisture						

REVIEWER COMMENTS (Condition Codes 1-No recommendations, 2- Monitoring unit, 3- Recommendation issued)

The DGA gas profile and combustible gas levels are similar to the previous sample. We expect to see carbon monoxide and carbon dioxide gases to increase over time as tank materials age. The CO2 to CO ratio was reported at 16 and the carbon oxide gas concentrations are similar to the previous samples. We monitor this ratio for indications of cellulose deterioration. The insulating fluid moisture saturation level based on the moisture content and a sample temperature of 53°C is about 5.7%. The insulating fluid physical properties are satisfactory. There are no recommendations based on these results. The next scheduled sample for 8/31/2025 is DGA

CLIENT COMMENTS

CURRENT & PREVIOUS SAMPLE REPORT RESULTS

Report Order ID	177997	175822	173192	171523	171036	168008
Sample Date	02/19/25	08/24/24	04/09/24	09/08/23	08/30/23	02/27/23
Condition Code	1	1	1	1	1	1
Sample Received Date	03/05/25	09/04/24	04/15/24	09/05/23	09/05/23	03/13/23
Sample Processed Date						03/23/23
Gas Pressure, psig:	2.5	1	2.5	2	2	1
Max. Temp. by Indicator (°C)	57	62	65	60	60	55
Temp. at Time of Sample, (°C)	53	60	62	0	60	50
Ambient Temperature (°F)	80	93	78	94	94	75
Hours Of Operation	0	0	0	0	0	0

DISSOLVED GAS ANALYSIS

Hydrogen, (H2), ppm	0	0	0	1		0
Oxygen, (O2), ppm	267	279	233	11935		273
Nitrogen, (N2), ppm	76695	63843	68291	65745		70707
Methane, (CH4), ppm	3	2	2	2		3
Carbon Monoxide, (CO), ppm	21	12	9	17		15
Carbon Dioxide, (CO2), ppm	332	325	245	503		318
Ethylene, (C2H4), ppm	0	0	0	0		0
Ethane, (C2H6), ppm	20	20	23	29		35
Acetylene, (C2H2), ppm	0	0	0	0		0
Combustible gas, ppm	44	34	34	49		53
% of Gas in oil by volume						
TCG est. in the gas space	0.0217	0.0155	0.0115	0.0216		0.0182

SCREEN TESTS

Dielectric Breakdown, KV	30	18			34	
Specific Gravity	0.8785	0.8792			0.8791	
Color	L2.0	L2.5			L2.5	
Acidity, mg KOH/g	0.012	0.006			0.014	
Interfacial Tension, dynes/cm	31.24	30.23			29.08	
Power Factor @ 25 °C, %	0.095	0.078			0.128	
Power Factor @ 100 °C, %						
Water, ppm	11	14		27		
PCB, ppm						



TOGA® - TEST REPORT

Condition Code: 1
ACCOUNT/LOCATION NUMBERS
80205870

COMPANY NAME CSW Energy		LOCATION Orange Cogeneration Facility			
LOCATION ADDRESS (No., Street, City, State, Zip) 1901 Clear Springs Rd., Bartow FL 33830					
UNIT DESIGNATION 216E100	SERIAL NUMBER MNL-9182	EQUIPMENT TYPE GSU - Unit Transformer	MANUFACTURER ABB	YEAR BUILT 1994	

SAMPLE REPORT ORDER DETAILS

SAMPLED BY		PCB LEVEL (ppm) Unknown		OIL PRESERVATION METHOD Conservator/Diaphragm					
COOLING METHOD OA/FA/FOA	OIL VOLUME 9,998 GALS	VOLTAGE KV	PRI 14	SEC 69	TER	SIZE MVA	PRI 49	SEC 64	TER 113
CONDITION CODE 1	SCHEDULED NEXT SAMPLE DATE 03/01/25	SCHEDULED TESTS DGA							

REVIEWER COMMENTS (Condition Codes 1-No recommendations, 2- Monitoring unit, 3- Recommendation issued)

The DGA gas profile and combustible gas levels are similar to the previous sample. We expect to see carbon monoxide and carbon dioxide gases to increase over time as tank materials age. The CO2 to CO ratio was reported at 23 and the carbon oxide gas concentrations are similar to the previous samples. We monitor this ratio for indications of cellulose deterioration. There are no recommendations based on these results. The next scheduled samples for 8/31/2025 are DGA, Screen, Moisture

CLIENT COMMENTS

CURRENT & PREVIOUS SAMPLE REPORT RESULTS

Report Order ID	177998	175823	173193	171037	168009	165946
Sample Date	02/19/25	08/24/24	04/09/24	08/30/23	02/27/23	09/09/22
Condition Code	1	1	1	1	1	2
Sample Received Date	03/05/25	09/04/24	04/15/24	09/05/23	03/13/23	09/14/22
Sample Processed Date					03/23/23	09/30/22
Gas Pressure, psig:	2.0	2	2.5	1.5	1	1.0
Max. Temp. by Indicator (°C)	50	62	65	62	55	70
Temp. at Time of Sample, (°C)	46	54	62	60	50	60
Ambient Temperature (°F)	80	93	78	94	75	84
Hours Of Operation	0	0	0	0	0	0

DISSOLVED GAS ANALYSIS

Hydrogen, (H2), ppm	0	0	0	1	0	0
Oxygen, (O2), ppm	260	204	213	184	244	677
Nitrogen, (N2), ppm	73714	62757	67971	72870	68008	71576
Methane, (CH4), ppm	5	4	6	12	15	25
Carbon Monoxide, (CO), ppm	17	9	8	16	14	20
Carbon Dioxide, (CO2), ppm	390	378	342	494	402	518
Ethylene, (C2H4), ppm	3	3	3	5	4	5
Ethane, (C2H6), ppm	79	82	92	128	128	152
Acetylene, (C2H2), ppm	0	0	0	0	0	0
Combustible gas, ppm	104	98	109	162	161	202
% of Gas in oil by volume						
TCG est. in the gas space	0.0224	0.0169	0.0158	0.0289	0.0271	0.0362

SCREEN TESTS

Dielectric Breakdown, KV	31	38	17
Specific Gravity	0.8795	0.8793	0.8796
Color	L2.5	L2.5	L2.0
Acidity, mg KOH/g	0.011	0.012	0.011
Interfacial Tension, dynes/cm	33.19	32.65	32.01
Power Factor @ 25 °C, %	0.038	0.017	0.037
Power Factor @ 100 °C, %			
Water, ppm	14	9	6
PCB, ppm			



TOGA® - TEST REPORT

Condition Code: 1
ACCOUNT/LOCATION NUMBERS
80205870

COMPANY NAME CSW Energy		LOCATION Orange Cogeneration Facility		
LOCATION ADDRESS (No., Street, City, State, Zip) 1901 Clear Springs Rd., Bartow FL 33830				
UNIT DESIGNATION 216E110	SERIAL NUMBER HBA1123-0101	EQUIPMENT TYPE GSU - Unit Transformer	MANUFACTURER ABB	YEAR BUILT 1994

SAMPLE REPORT ORDER DETAILS

SAMPLED BY Steve Shore		PCB LEVEL (ppm) Unknown		OIL PRESERVATION METHOD Gas Blanketed - Sealed					
COOLING METHOD OA/FA	OIL VOLUME 1,347 GALS	VOLTAGE KV	PRI 14	SEC 4	TER	SIZE MVA	PRI 6	SEC	TER
CONDITION CODE 1	SCHEDULED NEXT SAMPLE DATE 03/01/25	SCHEDULED TESTS DGA, Screen, Moisture							

REVIEWER COMMENTS (Condition Codes 1-No recommendations, 2- Monitoring unit, 3- Recommendation issued)
 There was a significant decrease in the combustible gas concentration from the historic trend. We expect to see carbon monoxide and carbon dioxide gases to increase over time as tank materials age. The CO2 to CO ratio was reported at 10 which is about 70% of the previous DGA with lower carbon oxide gas concentrations. We monitor this ratio for indications of cellulose deterioration. The dissolved moisture content is elevated but it is below the IEEE guideline of 35 ppm. Elevated dissolved moisture levels can accelerate sludge formation and degrade the insulation system. The cellulose material can also become saturated making it difficult to dehydrate the insulating fluid. Elevated moisture can accelerate the rate of cellulose deterioration and decrease the ability of the insulation system to perform its function. The insulating fluid moisture saturation level based on the moisture content and a sample temperature of 46°C is about 21.9%. We will trend the increase in the fluid's color index at the next routine sample. The insulating fluid physical properties are satisfactory. There are no recommendations based on these results. The next scheduled samples for 8/31/2025 are DGA, Screen, Moisture

CLIENT COMMENTS

CURRENT & PREVIOUS SAMPLE REPORT RESULTS

Report Order ID	177999	175824	173194	171038	170330	169362
Sample Date	02/19/25	08/24/24	04/09/24	08/30/23	07/05/23	05/24/23
Condition Code	1	1	2	3	3	2
Sample Received Date	03/05/25	09/04/24	04/15/24	09/05/23	07/12/23	06/01/23
Sample Processed Date						
Gas Pressure, psig:	1.5	1.5	1.5	1	1	2.0
Max. Temp. by Indicator (°C)	51	67	58	62	65	55
Temp. at Time of Sample, (°C)	46	52	62	68	68	53
Ambient Temperature (°F)	80	93	78	94	98	91
Hours Of Operation	0	0	0	0	0	0

DISSOLVED GAS ANALYSIS

Hydrogen, (H2), ppm	6	0	0	0	0	0
Oxygen, (O2), ppm	13983	2155	3326	15045	2616	2839
Nitrogen, (N2), ppm	62479	62093	62694	66210	70324	68123
Methane, (CH4), ppm	6	90	92	85	106	99
Carbon Monoxide, (CO), ppm	464	1221	1195	794	1352	1261
Carbon Dioxide, (CO2), ppm	4830	7398	6954	7079	7847	7791
Ethylene, (C2H4), ppm	8	137	145	144	162	152
Ethane, (C2H6), ppm	2	25	25	27	29	26
Acetylene, (C2H2), ppm	0	2	1	2	2	2
Combustible gas, ppm	486	1475	1458	1052	1651	1540
% of Gas in oil by volume						
TCG est. in the gas space	0.4939	1.4143	1.3616	0.8012	1.3849	1.3308

SCREEN TESTS

Dielectric Breakdown, KV	35		34		
Specific Gravity	0.88		0.8844		
Color	L1.5		L0.5		
Acidity, mg KOH/g	0.02		0.013		
Interfacial Tension, dynes/cm	37.02		41.14		
Power Factor @ 25 °C, %	0.036		0.002		
Power Factor @ 100 °C, %					
Water, ppm	33		8		
PCB, ppm					



TOGA® - TEST REPORT

Condition Code: 1
ACCOUNT/LOCATION NUMBERS
80205870

COMPANY NAME CSW Energy		LOCATION Orange Cogeneration Facility		
LOCATION ADDRESS (No., Street, City, State, Zip) 1901 Clear Springs Rd., Bartow FL 33830				
UNIT DESIGNATION 116E110	SERIAL NUMBER ZAV9721-0101	EQUIPMENT TYPE GSU - Unit Transformer	MANUFACTURER ABB	YEAR BUILT 1994

SAMPLE REPORT ORDER DETAILS

SAMPLED BY Steve Shore		PCB LEVEL (ppm) Unknown	OIL PRESERVATION METHOD Gas Blanketed - Sealed						
COOLING METHOD OA/FA	OIL VOLUME 1,347 GALS	VOLTAGE KV	PRI 14	SEC 4	TER 7	SIZE MVA	PRI 6	SEC 7	TER 7
CONDITION CODE 1	SCHEDULED NEXT SAMPLE DATE 03/01/25	SCHEDULED TESTS DGA							
REVIEWER COMMENTS (Condition Codes 1-No recommendations, 2- Monitoring unit, 3- Recommendation issued)									

The DGA gas profile and combustible gas levels are similar to the previous sample. We expect to see carbon monoxide and carbon dioxide gases to increase over time as tank materials age. The CO2 to CO ratio was reported at 17 and the carbon oxide gas concentrations are similar to the previous samples. We monitor this ratio for indications of cellulose deterioration. There are no recommendations based on these results. The next scheduled samples for 8/31/2025 are DGA, Screen, Moisture

CLIENT COMMENTS

CURRENT & PREVIOUS SAMPLE REPORT RESULTS

Report Order ID	178000	175825	173195	171039	168011	165948
Sample Date	02/19/25	08/24/24	04/09/24	08/30/23	02/27/23	09/09/22
Condition Code	1	2	1	1	1	1
Sample Received Date	03/05/25	09/04/24	04/15/24	09/05/23	03/13/23	09/14/22
Sample Processed Date					03/23/23	09/30/22
Gas Pressure, psig:	2.0	1.2	2.0	2	2	1.0
Max. Temp. by Indicator (°C)	50	52	60	60	50	52
Temp. at Time of Sample, (°C)	42	44	50	50	40	46
Ambient Temperature (°F)		93	78	94	75	84
Hours Of Operation	0	0	0	0	0	0

DISSOLVED GAS ANALYSIS

Hydrogen, (H2), ppm	4	3	2	3	3	0
Oxygen, (O2), ppm	1233	2369	1000	3889	994	2750
Nitrogen, (N2), ppm	73556	65584	66327	72981	66308	70066
Methane, (CH4), ppm	17	16	16	19	17	20
Carbon Monoxide, (CO), ppm	359	277	286	346	338	379
Carbon Dioxide, (CO2), ppm	6080	5694	5625	6453	5945	6510
Ethylene, (C2H4), ppm	8	6	4	4	3	3
Ethane, (C2H6), ppm	4	3	3	3	3	3
Acetylene, (C2H2), ppm	0	0	0	0	0	0
Combustible gas, ppm	392	305	311	375	364	405
% of Gas in oil by volume						
TCG est. in the gas space	0.3631	0.3118	0.3187	0.3444	0.3772	0.3872

SCREEN TESTS

Dielectric Breakdown, KV		10		35		30
Specific Gravity		0.884		0.884		0.885
Color		L0.5		L1.0		L1.0
Acidity, mg KOH/g		0.013		0.01		0.004
Interfacial Tension, dynes/cm		41.6		40.7		39
Power Factor @ 25 °C, %		0.005		0.03		0.005
Power Factor @ 100 °C, %						
Water, ppm		13		17		7
PCB, ppm						



TOGA® - TEST REPORT

Condition Code: 1
ACCOUNT/LOCATION NUMBERS
80205870

COMPANY NAME CSW Energy		LOCATION Orange Cogeneration Facility		
LOCATION ADDRESS (No., Street, City, State, Zip) 1901 Clear Springs Rd., Bartow FL 33830				
UNIT DESIGNATION 116E100	SERIAL NUMBER MNL-9183	EQUIPMENT TYPE GSU - Unit Transformer	MANUFACTURER ABB	YEAR BUILT 1994

SAMPLE REPORT ORDER DETAILS

SAMPLED BY Steve Shore		PCB LEVEL (ppm) Unknown		OIL PRESERVATION METHOD Gas Blanketed - Sealed					
COOLING METHOD OA/FA	OIL VOLUME 4,828 GALS	VOLTAGE KV	PRI 14	SEC 69	TER	SIZE MVA	PRI 49	SEC 66	TER
CONDITION CODE 1	SCHEDULED NEXT SAMPLE DATE 08/31/25	SCHEDULED TESTS DGA							

REVIEWER COMMENTS (Condition Codes 1-No recommendations, 2- Monitoring unit, 3- Recommendation issued)

The DGA gas profile and combustible gas levels are similar to the previous sample. We expect to see carbon monoxide and carbon dioxide gases to increase over time as tank materials age. The CO2 to CO ratio was reported at 36 and the carbon oxide gas concentrations are similar to the previous samples. We monitor this ratio for indications of cellulose deterioration. The insulating fluid moisture saturation level based on the moisture content and a sample temperature of 55°C is about 5.8%. The insulating fluid physical properties are satisfactory. There are no recommendations based on these results. The next scheduled sample for 3/1/2026 is DGA

CLIENT COMMENTS

CURRENT & PREVIOUS SAMPLE REPORT RESULTS

Report Order ID	181006	177997	175822	173192	171523	171036
Sample Date	08/15/25	02/19/25	08/24/24	04/09/24	09/08/23	08/30/23
Condition Code	1	1	1	1	1	1
Sample Received Date	08/25/25	03/05/25	09/04/24	04/15/24	09/05/23	09/05/23
Sample Processed Date						
Gas Pressure, psig:	2	2.5	1	2.5	2	2
Max. Temp. by Indicator (°C)	55	57	62	65	60	60
Temp. at Time of Sample, (°C)	45	53	60	62	0	60
Ambient Temperature (°F)	95	80	93	78	94	94
Hours Of Operation	0	0	0	0	0	0

DISSOLVED GAS ANALYSIS

Hydrogen, (H2), ppm	0	0	0	0	1	
Oxygen, (O2), ppm	172	267	279	233	11935	
Nitrogen, (N2), ppm	68466	76695	63843	68291	65745	
Methane, (CH4), ppm	3	3	2	2	2	
Carbon Monoxide, (CO), ppm	10	21	12	9	17	
Carbon Dioxide, (CO2), ppm	361	332	325	245	503	
Ethylene, (C2H4), ppm	0	0	0	0	0	
Ethane, (C2H6), ppm	19	20	20	23	29	
Acetylene, (C2H2), ppm	0	0	0	0	0	
Combustible gas, ppm	32	44	34	34	49	
% of Gas in oil by volume						
TCG est. in the gas space	0.0126	0.0217	0.0155	0.0115	0.0216	

SCREEN TESTS

Dielectric Breakdown, KV	24	30	18			34
Specific Gravity	0.88	0.878	0.879			0.879
Color	L2.5	L2.0	L2.5			L2.5
Acidity, mg KOH/g	0.012	0.012	0.006			0.014
Interfacial Tension, dynes/cm	45.8	31.2	30.2			29.1
Power Factor @ 25 °C, %	0.097	0.095	0.078			0.128
Power Factor @ 100 °C, %						
Water, ppm	12	11	14		27	
PCB, ppm						



TOGA® - TEST REPORT

Condition Code: 1
ACCOUNT/LOCATION NUMBERS
80205870

COMPANY NAME CSW Energy	LOCATION Orange Cogeneration Facility			
LOCATION ADDRESS (No., Street, City, State, Zip) 1901 Clear Springs Rd., Bartow FL 33830				
UNIT DESIGNATION 216E100	SERIAL NUMBER MNL-9182	EQUIPMENT TYPE GSU - Unit Transformer	MANUFACTURER ABB	YEAR BUILT 1994

SAMPLE REPORT ORDER DETAILS

SAMPLED BY Steve Shore	PCB LEVEL (ppm) Unknown	OIL PRESERVATION METHOD Conservator/Diaphragm							
COOLING METHOD OA/FA/FOA	OIL VOLUME 9,998 GALS	VOLTAGE KV	PRI 14	SEC 69	TER	SIZE MVA	PRI 49	SEC 64	TER 113
CONDITION CODE 1	SCHEDULED NEXT SAMPLE DATE 08/31/25	SCHEDULED TESTS DGA, Screen, Moisture							

REVIEWER COMMENTS (Condition Codes 1-No recommendations, 2- Monitoring unit, 3- Recommendation issued)

The DGA gas profile and combustible gas levels are similar to the previous sample. We expect to see carbon monoxide and carbon dioxide gases to increase over time as tank materials age. The CO2 to CO ratio was reported at 46 and the carbon oxide gas concentrations are similar to the previous samples. We monitor this ratio for indications of cellulose deterioration. The insulating fluid moisture saturation level based on the moisture content and a sample temperature of 55°C is about 3.9%. The insulating fluid physical properties are satisfactory. There are no recommendations based on these results. The next scheduled sample for 3/1/2026 is DGA

CLIENT COMMENTS

CURRENT & PREVIOUS SAMPLE REPORT RESULTS

Report Order ID	181007	177998	175823	173193	171037	168009
Sample Date	08/15/25	02/19/25	08/24/24	04/09/24	08/30/23	02/27/23
Condition Code	1	1	1	1	1	1
Sample Received Date	08/25/25	03/05/25	09/04/24	04/15/24	09/05/23	03/13/23
Sample Processed Date						03/23/23
Gas Pressure, psig:	6	2.0	2	2.5	1.5	1
Max. Temp. by Indicator (°C)	60	50	62	65	62	55
Temp. at Time of Sample, (°C)	55	46	54	62	60	50
Ambient Temperature (°F)	95	80	93	78	94	75
Hours Of Operation	0	0	0	0	0	0

DISSOLVED GAS ANALYSIS

Hydrogen, (H2), ppm	0	0	0	0	1	0
Oxygen, (O2), ppm	189	260	204	213	184	244
Nitrogen, (N2), ppm	65158	73714	62757	67971	72870	68008
Methane, (CH4), ppm	3	5	4	6	12	15
Carbon Monoxide, (CO), ppm	9	17	9	8	16	14
Carbon Dioxide, (CO2), ppm	411	390	378	342	494	402
Ethylene, (C2H4), ppm	2	3	3	3	5	4
Ethane, (C2H6), ppm	73	79	82	92	128	128
Acetylene, (C2H2), ppm	0	0	0	0	0	0
Combustible gas, ppm	87	104	98	109	162	161
% of Gas in oil by volume						
TCG est. in the gas space	0.0154	0.0224	0.0169	0.0158	0.0289	0.0271

SCREEN TESTS

Dielectric Breakdown, KV	33		31		38	
Specific Gravity	0.879		0.88		0.879	
Color	L2.0		L2.5		L2.5	
Acidity, mg KOH/g	0.014		0.011		0.012	
Interfacial Tension, dynes/cm	32.6		33.2		32.6	
Power Factor @ 25 °C, %	0.046		0.038		0.017	
Power Factor @ 100 °C, %						
Water, ppm	8		14		9	
PCB, ppm						



TOGA® - TEST REPORT

Condition Code: 1
ACCOUNT/LOCATION NUMBERS
80205870

COMPANY NAME CSW Energy		LOCATION Orange Cogeneration Facility		
LOCATION ADDRESS (No., Street, City, State, Zip) 1901 Clear Springs Rd., Bartow FL 33830				
UNIT DESIGNATION New Xfer	SERIAL NUMBER 121034273A	EQUIPMENT TYPE Transformer	MANUFACTURER	YEAR BUILT 2025

SAMPLE REPORT ORDER DETAILS

SAMPLED BY Steve Shore		PCB LEVEL (ppm) Unknown		OIL PRESERVATION METHOD Gas Blanketed - Bottle					
COOLING METHOD OA	OIL VOLUME GALS	VOLTAGE KV	PRI 14	SEC 4	TER	SIZE MVA	PRI 6	SEC	TER
CONDITION CODE 1	SCHEDULED NEXT SAMPLE DATE 08/31/25	SCHEDULED TESTS DGA, Screen, Moisture							

REVIEWER COMMENTS (Condition Codes 1-No recommendations, 2- Monitoring unit, 3- Recommendation issued)
 The combustible gas levels are typical of a new power transformer but we are monitoring the ethylene gas concentration. We expect to see carbon monoxide and carbon dioxide gases to increase over time as tank materials age. The CO2 to CO ratio was reported at 20 which is about will be trended at the next routine sample. We monitor this ratio for indications of cellulose deterioration. The dissolved moisture content is elevated but it is below the IEEE guideline of 35 ppm. Elevated dissolved moisture levels can accelerate sludge formation and degrade the insulation system. The cellulose material can also become saturated making it difficult to dehydrate the insulating fluid. Elevated moisture can accelerate the rate of cellulose deterioration and decrease the ability of the insulation system to perform its function. The insulating fluid moisture saturation level based on the moisture content and a sample temperature of 60°C is about 13.6%. The insulating fluid physical properties are satisfactory. There are no recommendations based on these results. The next scheduled sample for 3/16/2026 is DGA

CLIENT COMMENTS

This is a new xfer we swapped out at the last outage. IC#121034273 Job #415419

CURRENT & PREVIOUS SAMPLE REPORT RESULTS

Report Order ID	181008				
Sample Date	08/15/25				
Condition Code	1				
Sample Received Date	08/25/25				
Sample Processed Date	09/16/25				
Gas Pressure, psig:	2				
Max. Temp. by Indicator (°C)	65				
Temp. at Time of Sample, (°C)	60				
Ambient Temperature (°F)	95				
Hours Of Operation	0				

DISSOLVED GAS ANALYSIS

Hydrogen, (H2), ppm	2				
Oxygen, (O2), ppm	2566				
Nitrogen, (N2), ppm	64043				
Methane, (CH4), ppm	12				
Carbon Monoxide, (CO), ppm	412				
Carbon Dioxide, (CO2), ppm	8178				
Ethylene, (C2H4), ppm	16				
Ethane, (C2H6), ppm	3				
Acetylene, (C2H2), ppm	0				
Combustible gas, ppm	445				
% of Gas in oil by volume					
TCG est. in the gas space	0.4617				

SCREEN TESTS

Dielectric Breakdown, KV	42				
Specific Gravity	0.88				
Color	L1.5				
Acidity, mg KOH/g	0.015				
Interfacial Tension, dynes/cm	32.1				
Power Factor @ 25 °C, %	0.062				
Power Factor @ 100 °C, %					
Water, ppm	33				
PCB, ppm					



TOGA® - TEST REPORT

Condition Code: 1	■
ACCOUNT/LOCATION NUMBERS	
80205870	

COMPANY NAME CSW Energy		LOCATION Orange Cogeneration Facility			
LOCATION ADDRESS (No., Street, City, State, Zip) 1901 Clear Springs Rd., Bartow FL 33830					
UNIT DESIGNATION 116E110	SERIAL NUMBER ZAV9721-0101	EQUIPMENT TYPE GSU - Unit Transformer	MANUFACTURER ABB	YEAR BUILT 1994	

SAMPLE REPORT ORDER DETAILS

SAMPLED BY Steve Shore		PCB LEVEL (ppm) Unknown		OIL PRESERVATION METHOD Gas Blanketed - Sealed					
COOLING METHOD OA/FA	OIL VOLUME 1,347 GALS	VOLTAGE KV	PRI 14	SEC 4	TER	SIZE MVA	PRI 6	SEC 7	TER
CONDITION CODE 1 ■	SCHEDULED NEXT SAMPLE DATE 08/31/25	SCHEDULED TESTS DGA, Screen, Moisture							

REVIEWER COMMENTS (Condition Codes 1-No recommendations, 2- Monitoring unit, 3- Recommendation issued)

The DGA gas profile and combustible gas levels are similar to the previous sample. We expect to see carbon monoxide and carbon dioxide gases to increase over time as tank materials age. The CO2 to CO ratio was reported at 20 and the carbon oxide gas concentrations are similar to the previous samples. We monitor this ratio for indications of cellulose deterioration. The insulating fluid moisture saturation level based on the moisture content and a sample temperature of 45°C is about 4.1%. The insulating fluid physical properties are satisfactory. There are no recommendations based on these results. The next scheduled sample for 3/1/2026 is DGA

CLIENT COMMENTS

CURRENT & PREVIOUS SAMPLE REPORT RESULTS

Report Order ID	181009	178000	175825	173195	171039	168011
Sample Date	08/15/25	02/19/25	08/24/24	04/09/24	08/30/23	02/27/23
Condition Code	1 ■	1 ■	2 ■	1 ■	1 ■	1 ■
Sample Received Date	08/25/25	03/05/25	09/04/24	04/15/24	09/05/23	03/13/23
Sample Processed Date	09/16/25					03/23/23
Gas Pressure, psig:	2	2.0	1.2	2.0	2	2
Max. Temp. by Indicator (°C)	55	50	52	60	60	50
Temp. at Time of Sample, (°C)	45	42	44	50	50	40
Ambient Temperature (°F)	95	95	93	78	94	75
Hours Of Operation	0	0	0	0	0	0

DISSOLVED GAS ANALYSIS

Hydrogen, (H2), ppm	0	4	3	2	3	3
Oxygen, (O2), ppm	1029	1233	2369	1000	3889	994
Nitrogen, (N2), ppm	65120	73556	65584	66327	72981	66308
Methane, (CH4), ppm	19	17	16	16	19	17
Carbon Monoxide, (CO), ppm	293	359	277	286	346	338
Carbon Dioxide, (CO2), ppm	6001	6080	5694	5625	6453	5945
Ethylene, (C2H4), ppm	8	8	6	4	4	3
Ethane, (C2H6), ppm	4	4	3	3	3	3
Acetylene, (C2H2), ppm	0	0	0	0	0	0
Combustible gas, ppm	324	392	305	311	375	364
% of Gas in oil by volume						
TCG est. in the gas space	0.3281	0.3631	0.3118	0.3187	0.3444	0.3772

SCREEN TESTS

Dielectric Breakdown, KV	41		10		35	
Specific Gravity	0.884		0.884		0.884	
Color	L1.0		L0.5		L1.0	
Acidity, mg KOH/g	0.005		0.013		0.01	
Interfacial Tension, dynes/cm	42.6		41.6		40.7	
Power Factor @ 25 °C, %	0.004		0.005		0.03	
Power Factor @ 100 °C, %						
Water, ppm	6		13		17	
PCB, ppm						

TO JUNCTION FOR WIRE CONNECTIONS SEE INVA 9181-04

#10 WIRE

9/1/74
LIS
LT
CDS

CONTROL CABINET "W"

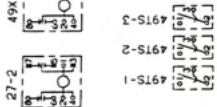
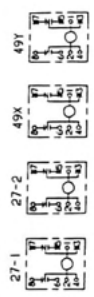
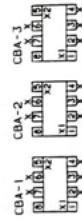

1 - 5.6V
2 - 5.6V
3 - 5.6V

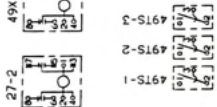

4-1
4-2
4-3
83
84
85
86
87
88
89
90
91
92
93
94
95
96
97
98
99
100

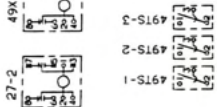

HTR-1
HTR-2

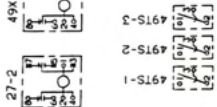

STATIONARY PANEL "A"

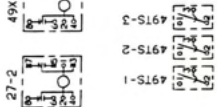

63 PANEL E

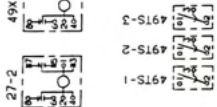

HINGED PANEL "B" (SHOWN REAR VIEW)

WIRE CONNECTIONS ON STAT CONTROL PANEL "A"

WIRE CODE	FROM	TO	DESTINATION
1	A	1	4-1
2	A	2	27-2
3	A	3	5
4	A	4	27-2
5	A	5	27-2
6	A	6	AT
7	A	7	83
8	A	8	49Y
9	A	9	49Y
10	A	10	49Y
11	A	11	49Y
12	A	12	49Y
13	A	13	49Y
14	A	14	49Y
15	A	15	49Y
16	A	16	49Y
17	A	17	49Y
18	A	18	49Y
19	A	19	49Y
20	A	20	49Y
21	A	21	49Y
22	A	22	49Y
23	A	23	49Y
24	A	24	49Y
25	A	25	49Y
26	A	26	49Y
27	A	27	49Y
28	A	28	49Y
29	A	29	49Y
30	A	30	49Y
31	A	31	49Y
32	A	32	49Y
33	A	33	49Y
34	A	34	49Y
35	A	35	49Y
36	A	36	49Y
37	A	37	49Y
38	A	38	49Y
39	A	39	49Y
40	A	40	49Y
41	A	41	49Y
42	A	42	49Y
43	A	43	49Y
44	A	44	49Y
45	A	45	49Y
46	A	46	49Y
47	A	47	49Y
48	A	48	49Y
49	A	49	49Y
50	A	50	49Y
51	A	51	49Y
52	A	52	49Y
53	A	53	49Y
54	A	54	49Y
55	A	55	49Y
56	A	56	49Y
57	A	57	49Y
58	A	58	49Y
59	A	59	49Y
60	A	60	49Y
61	A	61	49Y
62	A	62	49Y
63	A	63	49Y
64	A	64	49Y
65	A	65	49Y
66	A	66	49Y
67	A	67	49Y
68	A	68	49Y
69	A	69	49Y
70	A	70	49Y
71	A	71	49Y
72	A	72	49Y
73	A	73	49Y
74	A	74	49Y
75	A	75	49Y
76	A	76	49Y
77	A	77	49Y
78	A	78	49Y
79	A	79	49Y
80	A	80	49Y
81	A	81	49Y
82	A	82	49Y
83	A	83	49Y
84	A	84	49Y
85	A	85	49Y
86	A	86	49Y
87	A	87	49Y
88	A	88	49Y
89	A	89	49Y
90	A	90	49Y
91	A	91	49Y
92	A	92	49Y
93	A	93	49Y
94	A	94	49Y
95	A	95	49Y
96	A	96	49Y
97	A	97	49Y
98	A	98	49Y
99	A	99	49Y
100	A	100	49Y

WIRE CONNECTIONS ON HINGED PANEL "B"

WIRE CODE	FROM	TO	DESTINATION
1	A	1	8-2
2	A	2	8-3
3	A	3	8-4
4	A	4	8-5
5	A	5	8-6
6	A	6	8-7
7	A	7	8-8
8	A	8	8-9
9	A	9	8-10
10	A	10	8-11
11	A	11	8-12
12	A	12	8-13
13	A	13	8-14
14	A	14	8-15
15	A	15	8-16
16	A	16	8-17
17	A	17	8-18
18	A	18	8-19
19	A	19	8-20
20	A	20	8-21
21	A	21	8-22
22	A	22	8-23
23	A	23	8-24
24	A	24	8-25
25	A	25	8-26
26	A	26	8-27
27	A	27	8-28
28	A	28	8-29
29	A	29	8-30
30	A	30	8-31
31	A	31	8-32
32	A	32	8-33
33	A	33	8-34
34	A	34	8-35
35	A	35	8-36
36	A	36	8-37
37	A	37	8-38
38	A	38	8-39
39	A	39	8-40
40	A	40	8-41
41	A	41	8-42
42	A	42	8-43
43	A	43	8-44
44	A	44	8-45
45	A	45	8-46
46	A	46	8-47
47	A	47	8-48
48	A	48	8-49
49	A	49	8-50
50	A	50	8-51
51	A	51	8-52
52	A	52	8-53
53	A	53	8-54
54	A	54	8-55
55	A	55	8-56
56	A	56	8-57
57	A	57	8-58
58	A	58	8-59
59	A	59	8-60
60	A	60	8-61
61	A	61	8-62
62	A	62	8-63
63	A	63	8-64
64	A	64	8-65
65	A	65	8-66
66	A	66	8-67
67	A	67	8-68
68	A	68	8-69
69	A	69	8-70
70	A	70	8-71
71	A	71	8-72
72	A	72	8-73
73	A	73	8-74
74	A	74	8-75
75	A	75	8-76
76	A	76	8-77
77	A	77	8-78
78	A	78	8-79
79	A	79	8-80
80	A	80	8-81
81	A	81	8-82
82	A	82	8-83
83	A	83	8-84
84	A	84	8-85
85	A	85	8-86
86	A	86	8-87
87	A	87	8-88
88	A	88	8-89
89	A	89	8-90
90	A	90	8-91
91	A	91	8-92
92	A	92	8-93
93	A	93	8-94
94	A	94	8-95
95	A	95	8-96
96	A	96	8-97
97	A	97	8-98
98	A	98	8-99
99	A	99	8-100

WIRE CONNECTIONS IN CONTROL CABINET "W"

WIRE CODE	FROM	TO	DESTINATION
1	A	1	8
2	A	2	9
3	A	3	3
4	A	4	3
5	A	5	3
6	A	6	1
7	A	7	1
8	A	8	1
9	A	9	1
10	A	10	1
11	A	11	1
12	A	12	1
13	A	13	1
14	A	14	1
15	A	15	1
16	A	16	1
17	A	17	1
18	A	18	1
19	A	19	1
20	A	20	1
21	A	21	1
22	A	22	1
23	A	23	1
24	A	24	1
25	A	25	1
26	A	26	1
27	A	27	1
28	A	28	1
29	A	29	1
30	A	30	1
31	A	31	1
32	A	32	1
33	A	33	1
34	A	34	1
35	A	35	1
36	A	36	1
37	A	37	1
38	A	38	1
39	A	39	1
40	A	40	1
41	A	41	1
42	A	42	1
43	A	43	1
44	A	44	1
45	A	45	1
46	A	46	1
47	A	47	1
48	A	48	1
49	A	49	1
50	A	50	1
51	A	51	1
52	A	52	1
53	A	53	1
54	A	54	1
55	A	55	1
56	A	56	1
57	A	57	1
58	A	58	1
59	A	59	1
60	A	60	1
61	A	61	1
62	A	62	1
63	A	63	1
64	A	64	1
65	A	65	1
66	A	66	1
67	A	67	1
68	A	68	1
69	A	69	1
70	A	70	1
71	A	71	1
72	A	72	1
73	A	73	1
74	A	74	1
75	A	75	1
76	A	76	1
77	A	77	1
78	A	78	1
79	A	79	1
80	A	80	1
81	A	81	1
82	A	82	1
83	A	83	1
84	A	84	1
85	A	85	1
86	A	86	1
87	A	87	1
88	A	88	1
89	A	89	1
90	A	90	1
91	A	91	1
92	A	92	1
93	A	93	1
94	A	94	1
95	A	95	1
96	A	96	1
97	A	97	1
98	A	98	1
99	A	99	1
100	A	100	1



HINGED PANEL "B" (SHOWN REAR VIEW)



STATIONARY PANEL "A"



63 PANEL E



HINGED PANEL "B" (SHOWN REAR VIEW)

- A SWITCH SHOWN WITH DOOR OPEN.
- B SHORTING BLOCKS.
- C JUMPER AND SHORT CIRCUIT FOR TEST AND SHIPMENT.
- D CUSTOMER AUXILIARY CONTACT. USE, IF DESIRED, TO SHUTDOWN COOLING.
- E CONNECT ON CUSTOMER'S SIDE OF "C" BLOCK.
- F THESE JUMPERS AND GROUND CONNECTION SHOULD REMAIN FOR OPERATION. CT'S ARE SPARES.

WIRE CONNECTIONS EXTERNAL TO CONTROL CABINET "W"

WIRE CODE	FROM	TO	SCALE
A3	A	5	10
A7	A	7	49-3
A8	A	8	49-2
A9	A	9	49-1
A10	A	10	49-3
A11	A	11	49-2
A12	A	12	49-1
A13	A	13	49-3
A14	A	14	49-2
A15	A	15	49-1
A16	A	16	49-3
A17	A	17	49-2
A18	A	18	49-1
A19	A	19	49-3
A20	A	20	49-2
A21	A	21	49-1
A22	A	22	49-3
A23	A	23	49-2
A24	A	24	49-1
A25	A	25	49-3
A26	A	26	49-2
A27	A	27	49-1
A28	A	28	49-3
A29	A	29	49-2
A30	A	30	49-1
A31	A	31	49-3
A32	A	32	49-2
A33	A	33	49-1
A34	A	34	49-3
A35	A	35	49-2
A36	A	36	49-1
A37	A	37	49-3
A38	A	38	49-2
A39	A	39	49-1
A40	A	40	49-3
A41	A	41	49-2
A42	A	42	49-1
A43	A	43	49-3
A44	A	44	49-2
A45	A	45	49-1
A46	A	46	49-3
A47	A	47	49-2
A48	A	48	49-1
A49	A	49	49-3
A50	A	50	49-2
A51	A	51	49-1
A52	A	52	49-3
A53	A	53	49-2
A54	A	54	49-1
A55	A	55	49-3
A56	A	56	49-2
A57	A	57	49-1
A58	A	58	49-3
A59	A	59	49-2
A60	A	60	49-1
A61	A	61	49-3
A62	A	62	49-2
A63	A	63	49-1
A64	A	64	49-3
A65	A	65	49-2
A66	A	66	49-1
A67	A	67	49-3
A68	A	68	49-2
A69	A	69	49-1
A70	A	70	49-3
A71	A	71	49-2
A72	A	72	49-1
A73	A	73	49-3
A74	A	74	49-2
A75	A	75	49-1
A76	A	76	49-3
A77	A	77	49-2
A78	A	78	49-1
A79	A	79	49-3
A80	A	80	49-2
A81	A	81	49-1
A82	A	82	49-3
A83	A	83	49-2
A84	A	84	49-1
A85	A	85	49-3
A86	A	86	49-2
A87	A	87	49-1
A88	A	88	49-3
A89	A	89	49-2
A90	A	90	49-1
A91	A	91	49-3
A92	A	92	49-2
A93	A	93	49-1
A94	A	94	49-3
A95	A	95	49-2
A96	A	96	49-1
A97	A	97	49-3
A98	A	98	49-2
A99	A	99	49-1
A100	A	100	49-3

① CONTACT MUST BE MANUALLY RESET AFTER TRIPPING.
 ② CONTACT CLOSURE ON LOW OIL LEVEL.
 ③ 2 CONDUCTOR WITH DRAIN SHIELDED CABLE.

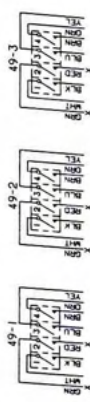
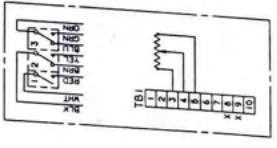
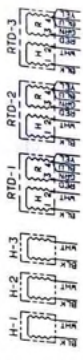
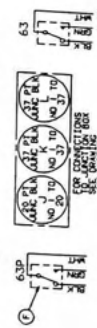
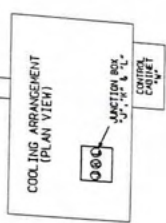

CUSTOMER - ZURN/VEPOD
 - EQUIPMENT TAG NO. 116E/100
 - ZURN/VEPOD ORANGE CONDENSATION FACILITY
 - TAG NO. 2055, FILE NO. 2055, P.O. NO. 999/10
 G.O.#P80114

ABB POWER T&D COMPANY INC.
 QU/TA TRANSFORMER
 CONNECTION WIRING DIAGRAM
 DIMENSIONS IN INCHES-SCALE NTS
 REF IN SEC
 APPROVED
 DRAWN
 MNL9183-05
 REV 1
 ST. LOUIS, MO.

PRINTS TO

1	A
2	A
3	A
4	A
5	A
6	A
7	A
8	A
9	A
10	A

SCHEMATIC DEVICE TERMINAL

WIRE - 62111BY
 TERMINALS - AMP PRE-INSULATED RING TONGUE
 CODE MARKERS - ADHESIVE

THIS DNG. TO BE CHANGED ON GRAPHICS SYSTEM ONLY

ABB POWER T & D COMPANY, INC.



ASEA BROWN BOVERI

THREE PHASE
60 HERTZ
TYPE 31
CORE FORM
TRANSFORMER
CLASS DA/FA
INSULOUR INSULATION

WINDING 72500RD, Y/41860 VOLTS
13800 VOLTS
44000/58666 KVA
44000/58666 KVA
42880/65706 KVA

55° C. AVG. RISE
55° C. AVG. RISE
42880/65706 KVA

SERIAL []

BALLONS OIL: TRANS. TANK []

IMPEDANCE [] % AT 44000 KVA, 72500 TO 13800 VOLTS

FULL WAVE IMPULSE TEST LEVEL: HIGH VOLTAGE 350 KV, LOW VOLTAGE 110 KV,
APPROX. WEIGHT IN LBS. CORE AND COLLS. []

DO NOT ATTEMPT TO HANDLE, INSTALL, USE OR SERVICE THIS
TRANSFORMER BEFORE READING INSTRUCTION BOOK MNL9183-12, TO
DO SO MAY LEAD TO BODILY INJURY OR PROPERTY DAMAGE OR BOTH.

CAUTION:

ARRESTERS H1 H2 H3

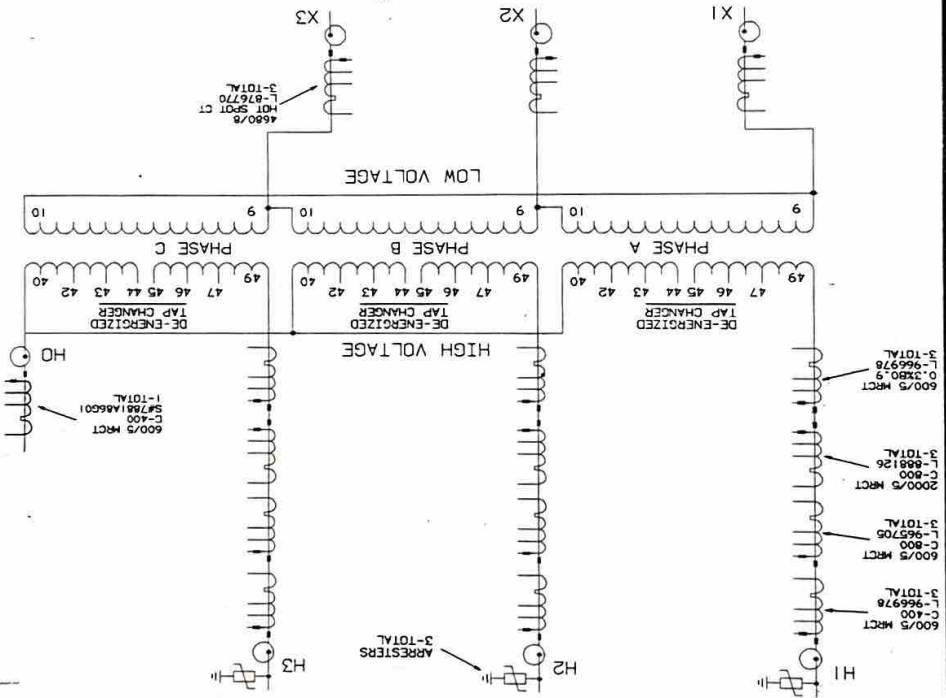

CONNECTIONS

WINDING	VOLTAGE	AMPERES AT 65706 KVA	POS. CONNECTS IN EACH PHASE
HIGH VOLTAGE	76125	498	44 TO 45
	74310	511	43 TO 45
	72500	523	43 TO 46
	70690	537	42 TO 46
	68875	551	42 TO 47
LOW VOLTAGE DELTA	2750		

PHASOR DIAGRAM:

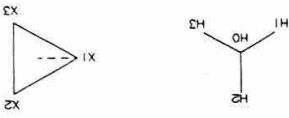

THE 25° C LIQUID LEVEL IS 16.50 INCHES BELOW TOP OF HIGHEST MANHOLE FLANGE. LIQUID LEVEL CHANGES FOR EACH 10° C CHANGE IN AVERAGE LIQUID TEMPERATURE.
THE TRANSFORMER MUST NOT BE ENERGIZED FROM ANY VOLTAGE SOURCE WHEN DE-ENERGIZED TAP CHANGERS ARE OPERATED.
THE HIGH VOLTAGE WINDING MUST BE PERMANENTLY GROUNDED EITHER DIRECTLY OR THROUGH A LOW IMPEDANCE. IF AN IMPEDANCE IS PLACED IN THE GROUND CIRCUIT, THE VOLTAGE FROM NEUTRAL TO GROUND DURING A FAULT MUST NOT EXCEED 15000 VOLTS.
THE TRANSFORMER IS DESIGNED FOR OPERATION BETWEEN PRESSURE LIMITS OF 6.5 POUNDS PER SQUARE INCH POSITIVE AND 6.5 POUNDS PER SQUARE INCH NEGATIVE.
THE TRANSFORMER TANK IS DESIGNED TO WITHSTAND COMPLETE VACUUM AND AN INTERNAL PRESSURE OF 10 POUNDS PER SQUARE INCH.

CONDUCTOR MATERIALS H.V., CU., X.V., CU.
UNWANKING WEIGHT (HEAVIEST PIECE) 81400 LBS.

MFG. DATE [] NPN# MNL9183-10 SUB B

MADE IN U.S.A.

0.022 STAINLESS STEEL #6240-SATIN FINISH-ETCHED-FILLED WITH BLACK ENAMEL.
1/4 IN. HOLE (4 TOTAL)
14-7/16 IN. BETWEEN CENTERS OF HOLES ON LONG EDGE OF PLATE.
9-15/16 IN. BETWEEN CENTERS OF HOLES ON SHORT EDGE OF PLATE.
ASSEMB. SEC. ST. LOUIS
PROVISION 211
REDUCE TO 7-1/2 IN X 15 IN.

TO JUNCTION
BOX FOR CONNECTIONS
SEE DRAWING 24

WIRE CONNECTIONS ON
HINGED PANEL "B"

WIRE CODE	FROM	TO	DESTINATION
1	1	1	1
2	2	2	2
3	3	3	3
4	4	4	4
5	5	5	5
6	6	6	6
7	7	7	7
8	8	8	8
9	9	9	9
10	10	10	10
11	11	11	11
12	12	12	12
13	13	13	13
14	14	14	14
15	15	15	15
16	16	16	16
17	17	17	17
18	18	18	18
19	19	19	19
20	20	20	20
21	21	21	21
22	22	22	22
23	23	23	23
24	24	24	24
25	25	25	25
26	26	26	26
27	27	27	27
28	28	28	28
29	29	29	29
30	30	30	30
31	31	31	31
32	32	32	32
33	33	33	33
34	34	34	34
35	35	35	35
36	36	36	36
37	37	37	37
38	38	38	38
39	39	39	39
40	40	40	40
41	41	41	41
42	42	42	42
43	43	43	43
44	44	44	44
45	45	45	45
46	46	46	46
47	47	47	47
48	48	48	48
49	49	49	49
50	50	50	50
51	51	51	51
52	52	52	52
53	53	53	53
54	54	54	54
55	55	55	55
56	56	56	56
57	57	57	57
58	58	58	58
59	59	59	59
60	60	60	60
61	61	61	61
62	62	62	62
63	63	63	63
64	64	64	64
65	65	65	65
66	66	66	66
67	67	67	67
68	68	68	68
69	69	69	69
70	70	70	70
71	71	71	71
72	72	72	72
73	73	73	73
74	74	74	74
75	75	75	75
76	76	76	76
77	77	77	77
78	78	78	78
79	79	79	79
80	80	80	80
81	81	81	81
82	82	82	82
83	83	83	83
84	84	84	84
85	85	85	85
86	86	86	86
87	87	87	87
88	88	88	88
89	89	89	89
90	90	90	90
91	91	91	91
92	92	92	92
93	93	93	93
94	94	94	94
95	95	95	95
96	96	96	96
97	97	97	97
98	98	98	98
99	99	99	99
100	100	100	100

CONTROL CABINET "W"

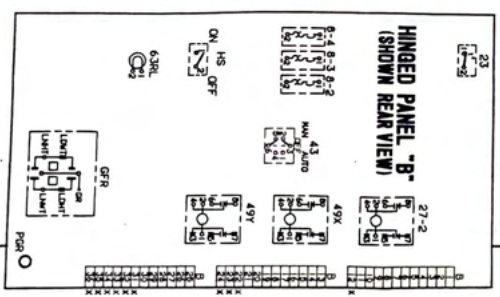
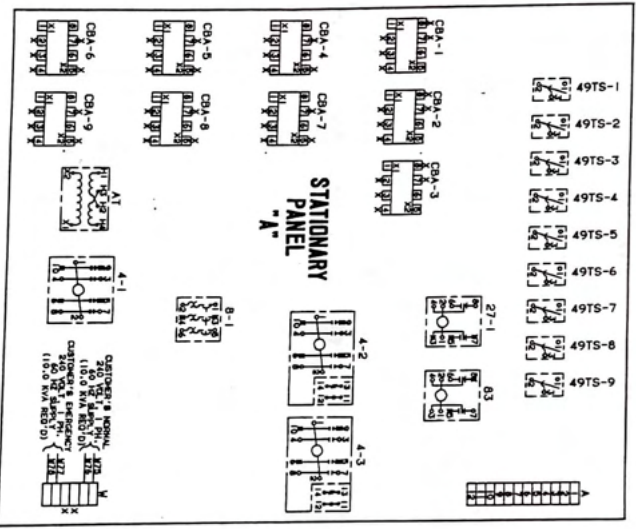

WIRE CONNECTIONS ON
STATIONARY PANEL "A"

WIRE CODE	FROM	TO	DESTINATION
1	1	1	1
2	2	2	2
3	3	3	3
4	4	4	4
5	5	5	5
6	6	6	6
7	7	7	7
8	8	8	8
9	9	9	9
10	10	10	10
11	11	11	11
12	12	12	12
13	13	13	13
14	14	14	14
15	15	15	15
16	16	16	16
17	17	17	17
18	18	18	18
19	19	19	19
20	20	20	20
21	21	21	21
22	22	22	22
23	23	23	23
24	24	24	24
25	25	25	25
26	26	26	26
27	27	27	27
28	28	28	28
29	29	29	29
30	30	30	30
31	31	31	31
32	32	32	32
33	33	33	33
34	34	34	34
35	35	35	35
36	36	36	36
37	37	37	37
38	38	38	38
39	39	39	39
40	40	40	40
41	41	41	41
42	42	42	42
43	43	43	43
44	44	44	44
45	45	45	45
46	46	46	46
47	47	47	47
48	48	48	48
49	49	49	49
50	50	50	50
51	51	51	51
52	52	52	52
53	53	53	53
54	54	54	54
55	55	55	55
56	56	56	56
57	57	57	57
58	58	58	58
59	59	59	59
60	60	60	60
61	61	61	61
62	62	62	62
63	63	63	63
64	64	64	64
65	65	65	65
66	66	66	66
67	67	67	67
68	68	68	68
69	69	69	69
70	70	70	70
71	71	71	71
72	72	72	72
73	73	73	73
74	74	74	74
75	75	75	75
76	76	76	76
77	77	77	77
78	78	78	78
79	79	79	79
80	80	80	80
81	81	81	81
82	82	82	82
83	83	83	83
84	84	84	84
85	85	85	85
86	86	86	86
87	87	87	87
88	88	88	88
89	89	89	89
90	90	90	90
91	91	91	91
92	92	92	92
93	93	93	93
94	94	94	94
95	95	95	95
96	96	96	96
97	97	97	97
98	98	98	98
99	99	99	99
100	100	100	100

- SWITCH SHOWN WITH DOOR OPEN.
- SHORTING BLOCKS.
- JUMPER AND SHORT CIRCUIT FOR TEST AND SHIPMENT.
- CUSTOMER AUXILIARY CONTACT. USE, IF DESIRED, TO SHUTDOWN COOLING.
- WIRE, JUMPER AND GROUND CONNECTION SHOULD BE IDENTIFIED BY DESIGNATION, CT'S AND SPANERS.

WIRE - 62111BY
TERMINALS - AMP PRE-INSULATED RING TONGUE
CODE MARKERS - ADHESIVE

NOTE: THE WIRE CONNECTIONS ADMINISTER THE PHYSICAL LAYOUT OF THE PANEL. THESE LISTING OR SYMBOL, MEAN TO MATCH WIRE CODE NO'S. CORRESPOND TO THOSE APPEARING ON THE IDENTIFIED TERMINAL.

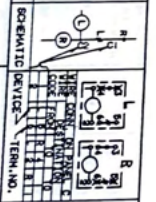

WIRE CONNECTIONS ON
HINGED PANEL "A"

WIRE CODE	FROM	TO	DESTINATION
1	1	1	1
2	2	2	2
3	3	3	3
4	4	4	4
5	5	5	5
6	6	6	6
7	7	7	7
8	8	8	8
9	9	9	9
10	10	10	10
11	11	11	11
12	12	12	12
13	13	13	13
14	14	14	14
15	15	15	15
16	16	16	16
17	17	17	17
18	18	18	18
19	19	19	19
20	20	20	20
21	21	21	21
22	22	22	22
23	23	23	23
24	24	24	24
25	25	25	25
26	26	26	26
27	27	27	27
28	28	28	28
29	29	29	29
30	30	30	30
31	31	31	31
32	32	32	32
33	33	33	33
34	34	34	34
35	35	35	35
36	36	36	36
37	37	37	37
38	38	38	38
39	39	39	39
40	40	40	40
41	41	41	41
42	42	42	42
43	43	43	43
44	44	44	44
45	45	45	45
46	46	46	46
47	47	47	47
48	48	48	48
49	49	49	49
50	50	50	50
51	51	51	51
52	52	52	52
53	53	53	53
54	54	54	54
55	55	55	55
56	56	56	56
57	57	57	57
58	58	58	58
59	59	59	59
60	60	60	60
61	61	61	61
62	62	62	62
63	63	63	63
64	64	64	64
65	65	65	65
66	66	66	66
67	67	67	67
68	68	68	68
69	69	69	69
70	70	70	70
71	71	71	71
72	72	72	72
73	73	73	73
74	74	74	74
75	75	75	75
76	76	76	76
77	77	77	77
78	78	78	78
79	79	79	79
80	80	80	80
81	81	81	81
82	82	82	82
83	83	83	83
84	84	84	84
85	85	85	85
86	86	86	86
87	87	87	87
88	88	88	88
89	89	89	89
90	90	90	90
91	91	91	91
92	92	92	92
93	93	93	93
94	94	94	94
95	95	95	95
96	96	96	96
97	97	97	97
98	98	98	98
99	99	99	99
100	100	100	100

CUSTOMER - ZURU/VERCO
EQUIPMENT TAG NO. 216E100
ORANGE COOPERATION FACILITY
CONTRACT NO. 2008, FILE NO. 200.1, P.O. NO. 0600114

REF. SCHEM. VIB. DIAGRAM UEL9182-04-SMT.1 & 2, CON. VIB. DIAGRAM UEL9182-05-SMT.2

ABB POWER T&D COMPANY INC.
647A CONNECTION WIRING DIAGRAM
DIMENSIONS IN INCHES-SCALE THIS
DRAWING IS VALID TO 31-28-74/REV 3

ABB POWER TRANSFORMER DIVISION
L9182-05
SHEET 1 OF 2 SHEETS



ABB POWER T & D COMPANY INC.

THREE PHASE
60 HERTZ
TYPE M
GSU
TRANSFORMER
CLASS DA/FA
INSULATOR INSULATION

WINDING
 72500GRD. Y/41860 VOLTS
 13800 VOLTS
 13800 VOLTS

55° C. AVG. RISE
 76000/101330 KVA
 33000/44000 KVA
 43000/57330 KVA

85° C. AVG. RISE
 85120/113450 KVA
 36960/49240 KVA
 48160/64210 KVA

L-SPCC LNL9182-08
 WINDING DIAGRAM LNL9182-04

SERIAL

BALLBOB OIL; TRANS. TANK

IMPEDANCE 13.07 % AT 33000 KVA, 72500 TO 13800(Y) VOLTS
 IMPEDANCE 17.18 % AT 43000 KVA, 72500 TO 13800(X) VOLTS
 IMPEDANCE 24.23 % AT 33000 KVA, 13800(X) TO 13800(Y) VOLTS

FULL WAVE IMPULSE TEST LEVEL: H-WDG. 350 KV, X-WDG. 110 KV, Y-WDG. 110 KV, HO NEUTRAL AND BUSHING 110 KV.

APPROX. WEIGHT IN LBS. COILS AND COILS CASE OIL TOTAL

CAUTION : DO NOT ATTEMPT TO HANDLE, INSTALL, USE OR SERVICE THIS TRANSFORMER BEFORE READING INSTRUCTION BOOK LNL9182-12. TO DO SO MAY LEAD TO BODILY INJURY OR PROPERTY DAMAGE OR BOTH.

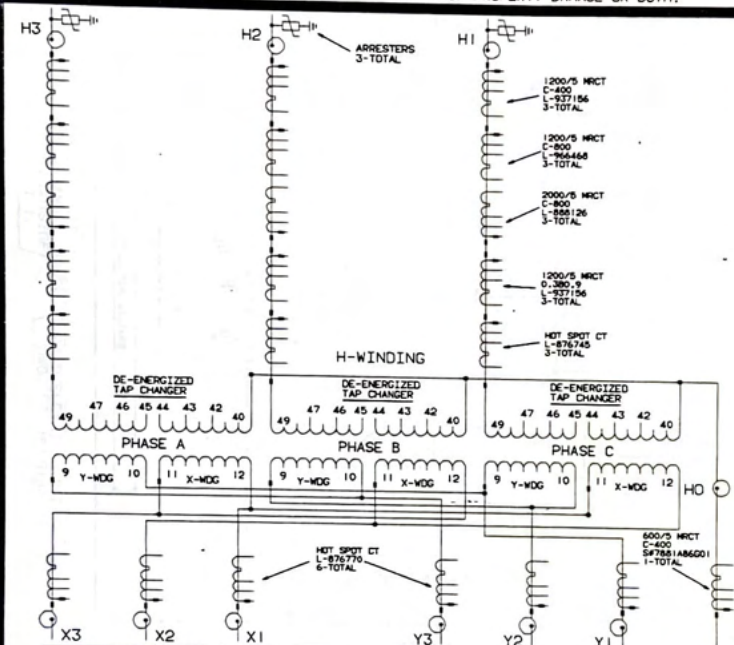

CONNECTIONS				
WINDING	VOLTAGE	AMPERES AT KVA	DE-ENERGIZED TAP CHANGER	
			POS.	CONNECTS IN EACH PHASE
H. V. GRD. WYE	76125	860	1	44 TO 45
	74310	881	2	43 TO 45
	72500	903	3	43 TO 46
	70690	927	4	42 TO 46
	68875	951	5	42 TO 47
Y. V. DELTA	13800	AMPERES AT 49240 KVA		
		2062		
X. V. DELTA	13800	AMPERES AT 64210 KVA		
		2687		

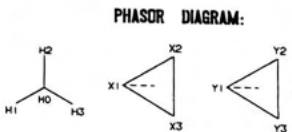

THE 25°C LIQUID LEVEL IS 14.50 INCHES BELOW TOP OF HIGHEST MAN-HOLE FLANGE. LIQUID LEVEL CHANGES 1.02 INCHES FOR EACH 10°C CHANGE IN AVERAGE LIQUID TEMPERATURE.

THE TRANSFORMER MUST NOT BE ENERGIZED FROM ANY VOLTAGE SOURCE WHEN DE-ENERGIZED TAP CHANGERS ARE OPERATED.

THE HIGH VOLTAGE WINDING NEUTRAL MUST BE PERMANENTLY GROUNDED EITHER DIRECTLY OR THROUGH A LOW IMPEDANCE. IF AN IMPEDANCE IS PLACED IN THE GROUND CIRCUIT, THE VOLTAGE FROM NEUTRAL TO GROUND DURING A FAULT MUST NOT EXCEED 15000 VOLTS.

THE TRANSFORMER IS DESIGNED FOR OPERATION BETWEEN PRESSURE LIMITS OF 6.5 POUNDS PER SQUARE INCH POSITIVE AND 6.5 POUNDS PER SQUARE INCH NEGATIVE.

THE TRANSFORMER TANK IS DESIGNED TO WITHSTAND COMPLETE VACUUM AND AN INTERNAL PRESSURE OF 10 POUNDS PER SQUARE INCH.

CONDUCTOR MATERIALS H.V. CU., X.V. CU., Y.V. CU. UNLANTAKING WEIGHT (HEAVIEST PIECE) 152650 LBS.
 MADE IN U.S.A. MFG. DATE PN# LNL9182-10 SUB C

.032 STAINLESS STEEL #6240-SATIN FINISH-ETCHED-FILLED WITH BLACK ENAMEL. 1/4 IN. HOLE (4 TOTAL)
 REDUCE TO 7-1/2 IN. X 15 IN. 14-7/16 IN. BETWEEN CENTERS OF HOLES ON LONG EDGE OF PLATE.
 ASSEMB. SEC. ST. LOUIS 6-15/16 IN. BETWEEN CENTERS OF HOLES ON SHORT EDGE OF PLATE.

SUB	B	LNL9182 CHANGED BY-CT'S PER CUSTOMER. ADDY T.V. TO CONDUCTOR MATERIALS	C	LNL9182 ADDED IMPEDANCE TO WINDING PLATE.	DATE	N.P. DRAFT	DATE	N.P. DRAFT	DATE
		N.P. DRAFT F.T. CROSS 2-22-74	N.P. DRAFT ED. JASPER 2-22-74	DATE 2-20-74	N.P. DRAFT	DATE	N.P. DRAFT	DATE	
	ENGINEER	RAJ BHOWM	ENGINEER	RAJ BHOWM	DATE 2-20-74	ENGINEER	DATE	ENGINEER	DATE
LNL9182-10	A	THIS DRAWING IS THE PROPERTY OF ABB POWER T & D COMPANY. IT IS TO BE USED ONLY FOR THE PROJECT AND NOT TO BE REPRODUCED OR TRANSMITTED IN ANY FORM OR BY ANY MEANS, ELECTRONIC OR MECHANICAL, INCLUDING PHOTOCOPYING, RECORDING, OR BY ANY INFORMATION STORAGE AND RETRIEVAL SYSTEM. WITHOUT THE WRITTEN PERMISSION OF ABB POWER T & D COMPANY.		REVISED TO TOP	NO. 1	NO. 2	NO. 3	NO. 4	NO. 5
				REF BY SEC	NO. 6	NO. 7	NO. 8	NO. 9	NO. 10
					ABB POWER T & D COMPANY INC. APPARATUS TRANSFORMER INSTRUCTION NAMEPLATE DIMENSIONS IN INCHES-SCALE NITS SUB C DATE F.T. CROSS 3/15/74 RAJ BHOWM 3/15/74 LNL9182-10 CHD. N. NEEDI 3/15/74 POWER TRANSFORMER DIVISION MANCIE, IN. / ST. LOUIS, MO				

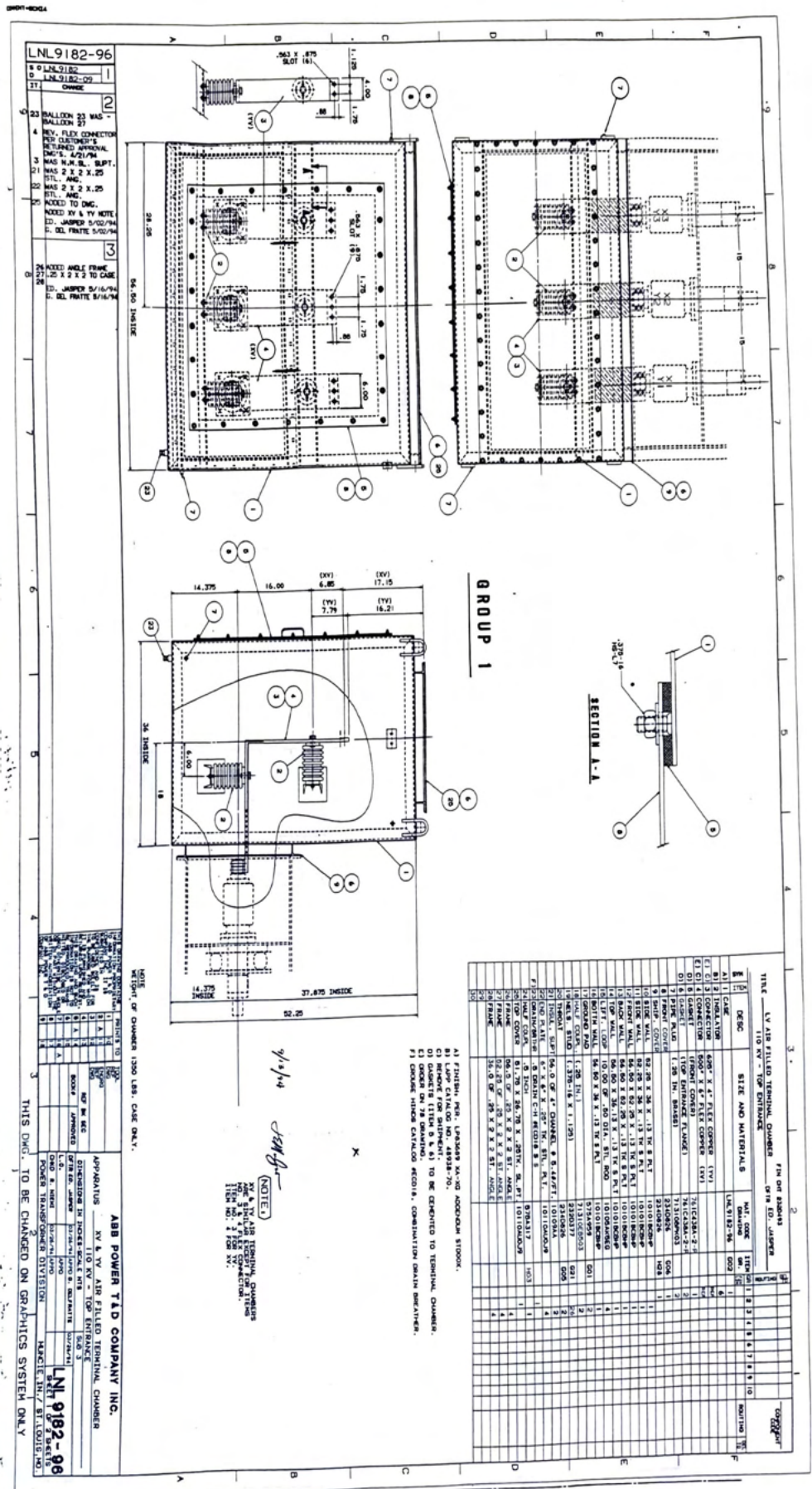

LNL 9182-96

6 0 LNL 9182-96
 10 LNL 9182-96
 21 CHANGE

23 BALLON 23 WAS BALLON 27

4 REV. FLEX CONNECTOR FOR CUSTOMER'S RETURNED APPROVAL DATE: 4/22/94

3 WAS N.H. SL. SUPT. 21 WAS 2 X 2 X .25 STL. ANG.

22 WAS 2 X 2 X .25 STL. ANG.

25 KNOCK TO DMC. KNOCKED BY 6 TV NOTE 22. JAMPER 5/16" DIA. DEL. FINITE 5/16" DIA.

26 KNOCK ANGLE FROM 22 X 2 X 2 TO CODE 22. JAMPER 5/16" DIA. DEL. FINITE 5/16" DIA.

GROUP 1

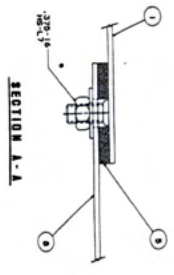

TITLE		FIG. OR. SHOW		QUANTITY																							
LV AIR FILLED TERMINAL CHAMBER WITH TERMINALS		110 KV - TOP ENTRANCE		1	2	3	4	5	6	7	8	9	10	11	12	13	14	15	16	17	18	19	20	21	22	23	
QTY	DESC	SIZE AND MATERIALS	MAT. CODE	ITEM NO.	1	2	3	4	5	6	7	8	9	10	11	12	13	14	15	16	17	18	19	20	21	22	23
1	A1	CHAMBER	48" X 4" FLEX CONNECT (TV)	001																							
1	A2	CHAMBER	48" X 4" FLEX CONNECT (TV)	002																							
1	B1	CONNECTOR	7/16" DIA. X 2" (FRONT COVER)	003																							
1	B2	CONNECTOR	7/16" DIA. X 2" (BACK COVER)	004																							
1	C1	CONNECTOR	7/16" DIA. X 2" (TOP ENTRANCE FLANGE)	005																							
1	D1	CONNECTOR	7/16" DIA. X 2" (TOP ENTRANCE FLANGE)	006																							
1	E1	CONNECTOR	7/16" DIA. X 2" (TOP ENTRANCE FLANGE)	007																							
1	F1	CONNECTOR	7/16" DIA. X 2" (TOP ENTRANCE FLANGE)	008																							
1	G1	CONNECTOR	7/16" DIA. X 2" (TOP ENTRANCE FLANGE)	009																							
1	H1	CONNECTOR	7/16" DIA. X 2" (TOP ENTRANCE FLANGE)	010																							
1	I1	CONNECTOR	7/16" DIA. X 2" (TOP ENTRANCE FLANGE)	011																							
1	J1	CONNECTOR	7/16" DIA. X 2" (TOP ENTRANCE FLANGE)	012																							
1	K1	CONNECTOR	7/16" DIA. X 2" (TOP ENTRANCE FLANGE)	013																							
1	L1	CONNECTOR	7/16" DIA. X 2" (TOP ENTRANCE FLANGE)	014																							
1	M1	CONNECTOR	7/16" DIA. X 2" (TOP ENTRANCE FLANGE)	015																							
1	N1	CONNECTOR	7/16" DIA. X 2" (TOP ENTRANCE FLANGE)	016																							
1	O1	CONNECTOR	7/16" DIA. X 2" (TOP ENTRANCE FLANGE)	017																							
1	P1	CONNECTOR	7/16" DIA. X 2" (TOP ENTRANCE FLANGE)	018																							
1	Q1	CONNECTOR	7/16" DIA. X 2" (TOP ENTRANCE FLANGE)	019																							
1	R1	CONNECTOR	7/16" DIA. X 2" (TOP ENTRANCE FLANGE)	020																							
1	S1	CONNECTOR	7/16" DIA. X 2" (TOP ENTRANCE FLANGE)	021																							
1	T1	CONNECTOR	7/16" DIA. X 2" (TOP ENTRANCE FLANGE)	022																							
1	U1	CONNECTOR	7/16" DIA. X 2" (TOP ENTRANCE FLANGE)	023																							
1	V1	CONNECTOR	7/16" DIA. X 2" (TOP ENTRANCE FLANGE)	024																							
1	W1	CONNECTOR	7/16" DIA. X 2" (TOP ENTRANCE FLANGE)	025																							
1	X1	CONNECTOR	7/16" DIA. X 2" (TOP ENTRANCE FLANGE)	026																							
1	Y1	CONNECTOR	7/16" DIA. X 2" (TOP ENTRANCE FLANGE)	027																							
1	Z1	CONNECTOR	7/16" DIA. X 2" (TOP ENTRANCE FLANGE)	028																							

NOTICE

REV. 11/1/94

ABB POWER T&D COMPANY INC.

APPARATUS BY INCH 110 KV - TOP ENTRANCE

BY 6 TV AIR FILLED TERMINAL CHAMBER

DISCREPANCY BY INCH 110 KV - TOP ENTRANCE

BY 6 TV AIR FILLED TERMINAL CHAMBER

POWER TRANSDUCER DIVISION

THIS DRAWING TO BE CHANGED ON GRAPHICS SYSTEM ONLY

- A1 FINISH, PER. LUBBERS M-VING APPROX. 1000X.
- B1 IMPROVE FOR SUPPLIER.
- C1 GASKETS (ITEMS B & S) TO BE EXPEDITED TO TERMINAL CHAMBER.
- D1 GASKETS (ITEMS B & S) TO BE EXPEDITED TO TERMINAL CHAMBER.
- E1 GASKETS (ITEMS B & S) TO BE EXPEDITED TO TERMINAL CHAMBER.
- F1 GASKETS (ITEMS B & S) TO BE EXPEDITED TO TERMINAL CHAMBER.
- G1 GASKETS (ITEMS B & S) TO BE EXPEDITED TO TERMINAL CHAMBER.
- H1 GASKETS (ITEMS B & S) TO BE EXPEDITED TO TERMINAL CHAMBER.
- I1 GASKETS (ITEMS B & S) TO BE EXPEDITED TO TERMINAL CHAMBER.
- J1 GASKETS (ITEMS B & S) TO BE EXPEDITED TO TERMINAL CHAMBER.
- K1 GASKETS (ITEMS B & S) TO BE EXPEDITED TO TERMINAL CHAMBER.
- L1 GASKETS (ITEMS B & S) TO BE EXPEDITED TO TERMINAL CHAMBER.
- M1 GASKETS (ITEMS B & S) TO BE EXPEDITED TO TERMINAL CHAMBER.
- N1 GASKETS (ITEMS B & S) TO BE EXPEDITED TO TERMINAL CHAMBER.
- O1 GASKETS (ITEMS B & S) TO BE EXPEDITED TO TERMINAL CHAMBER.
- P1 GASKETS (ITEMS B & S) TO BE EXPEDITED TO TERMINAL CHAMBER.
- Q1 GASKETS (ITEMS B & S) TO BE EXPEDITED TO TERMINAL CHAMBER.
- R1 GASKETS (ITEMS B & S) TO BE EXPEDITED TO TERMINAL CHAMBER.
- S1 GASKETS (ITEMS B & S) TO BE EXPEDITED TO TERMINAL CHAMBER.
- T1 GASKETS (ITEMS B & S) TO BE EXPEDITED TO TERMINAL CHAMBER.
- U1 GASKETS (ITEMS B & S) TO BE EXPEDITED TO TERMINAL CHAMBER.
- V1 GASKETS (ITEMS B & S) TO BE EXPEDITED TO TERMINAL CHAMBER.
- W1 GASKETS (ITEMS B & S) TO BE EXPEDITED TO TERMINAL CHAMBER.
- X1 GASKETS (ITEMS B & S) TO BE EXPEDITED TO TERMINAL CHAMBER.
- Y1 GASKETS (ITEMS B & S) TO BE EXPEDITED TO TERMINAL CHAMBER.
- Z1 GASKETS (ITEMS B & S) TO BE EXPEDITED TO TERMINAL CHAMBER.

